



Chipsmall Limited consists of a professional team with an average of over 10 year of expertise in the distribution of electronic components. Based in Hongkong, we have already established firm and mutual-benefit business relationships with customers from,Europe,America and south Asia,supplying obsolete and hard-to-find components to meet their specific needs.

With the principle of "Quality Parts,Customers Priority,Honest Operation,and Considerate Service",our business mainly focus on the distribution of electronic components. Line cards we deal with include Microchip,ALPS,ROHM,Xilinx,Pulse,ON,Everlight and Freescale. Main products comprise IC,Modules,Potentiometer,IC Socket,Relay,Connector.Our parts cover such applications as commercial,industrial, and automotives areas.

We are looking forward to setting up business relationship with you and hope to provide you with the best service and solution. Let us make a better world for our industry!



Contact us

Tel: +86-755-8981 8866 Fax: +86-755-8427 6832

Email & Skype: info@chipsmall.com Web: www.chipsmall.com

Address: A1208, Overseas Decoration Building, #122 Zhenhua RD., Futian, Shenzhen, China



THIS DRAWING IS UNPUBLISHED. RELEASED FOR PUBLICATION 20
 © COPYRIGHT 20 BY TYCO ELECTRONICS CORPORATION. ALL RIGHTS RESERVED.

LOC	DIST	REVISIONS			
P	LTR	DESCRIPTION	DATE	DWN	APVD
CE	16	B	RELEASE PER 0A00-0185-04	08JUN04	KG DW
		C	ECR-07-018681	21AUG07	KG DW
		D	ECR-09-011638	22MAY2009	KG DW
		DI	ECR-09-024182	05NOV2009	KG DW

NOTES:

1. THIS PRODUCT HAS NOT COMPLETED VALIDATION TESTING.
2. PROTECTIVE LABEL APPLIED AFTER FINAL CLEAN ROOM TEST TO PREVENT OPTICAL CAVITY CONTAMINATION. REMOVE ONLY WHEN READY TO ASSEMBLE.
3. SINGLEMODE IDENTIFIER
4. OPTIMIZED FOR 1550nm IDENTIFIER.
5. FOR USE WITH JACKETED CABLE FERRULE ASSEMBLY P/N 1754456-1, 125um, OR 1754456-2, 126um. ONE PER FIBER; PC-POLISH.
6. FOR USE WITH FERRULE ASSEMBLY KIT P/N 1754700-1, 125um, OR 1754700-2, 126um. ONE PER FIBER; PC-POLISH.

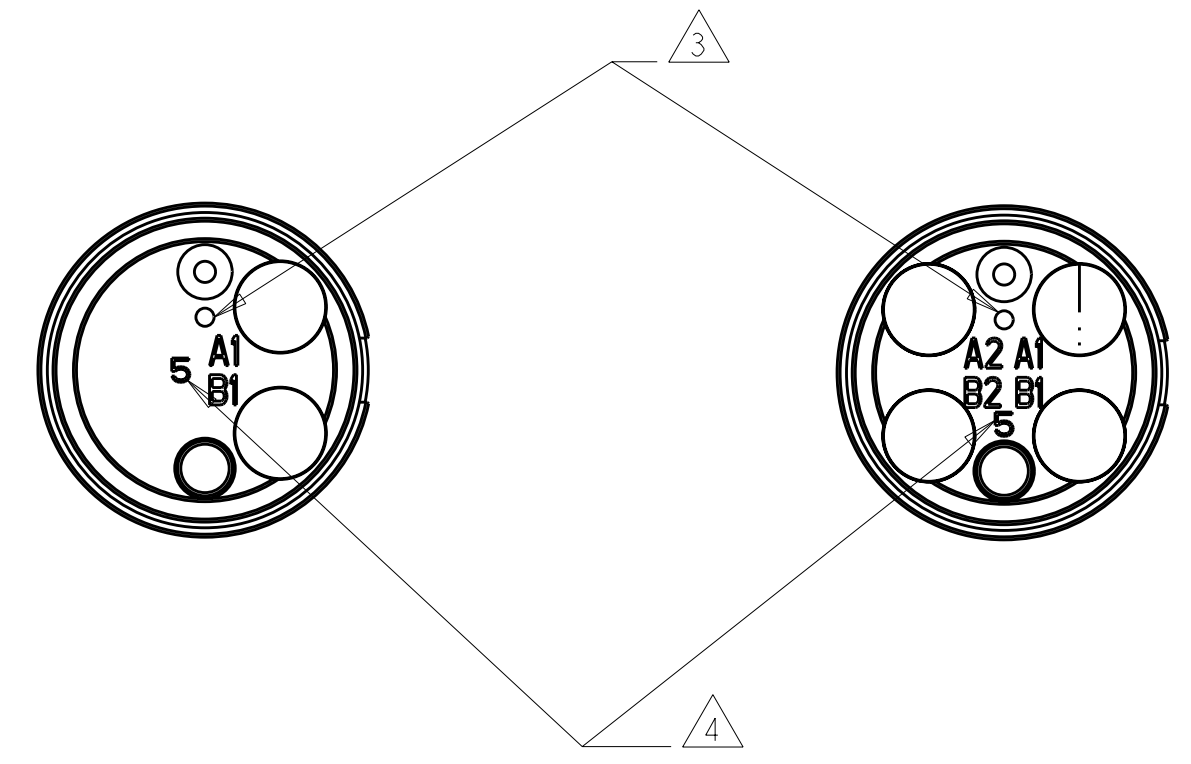
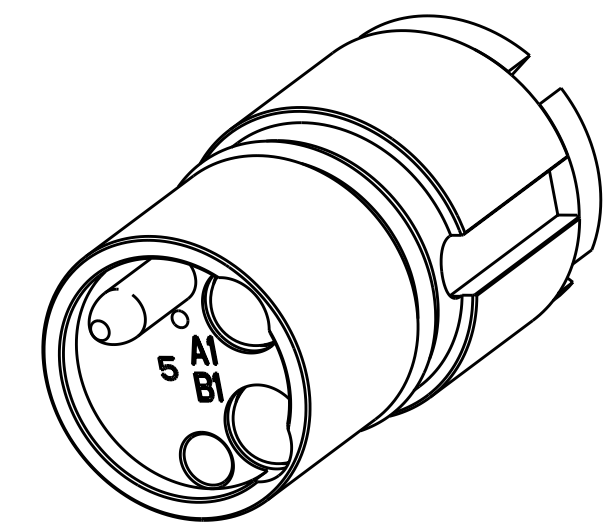
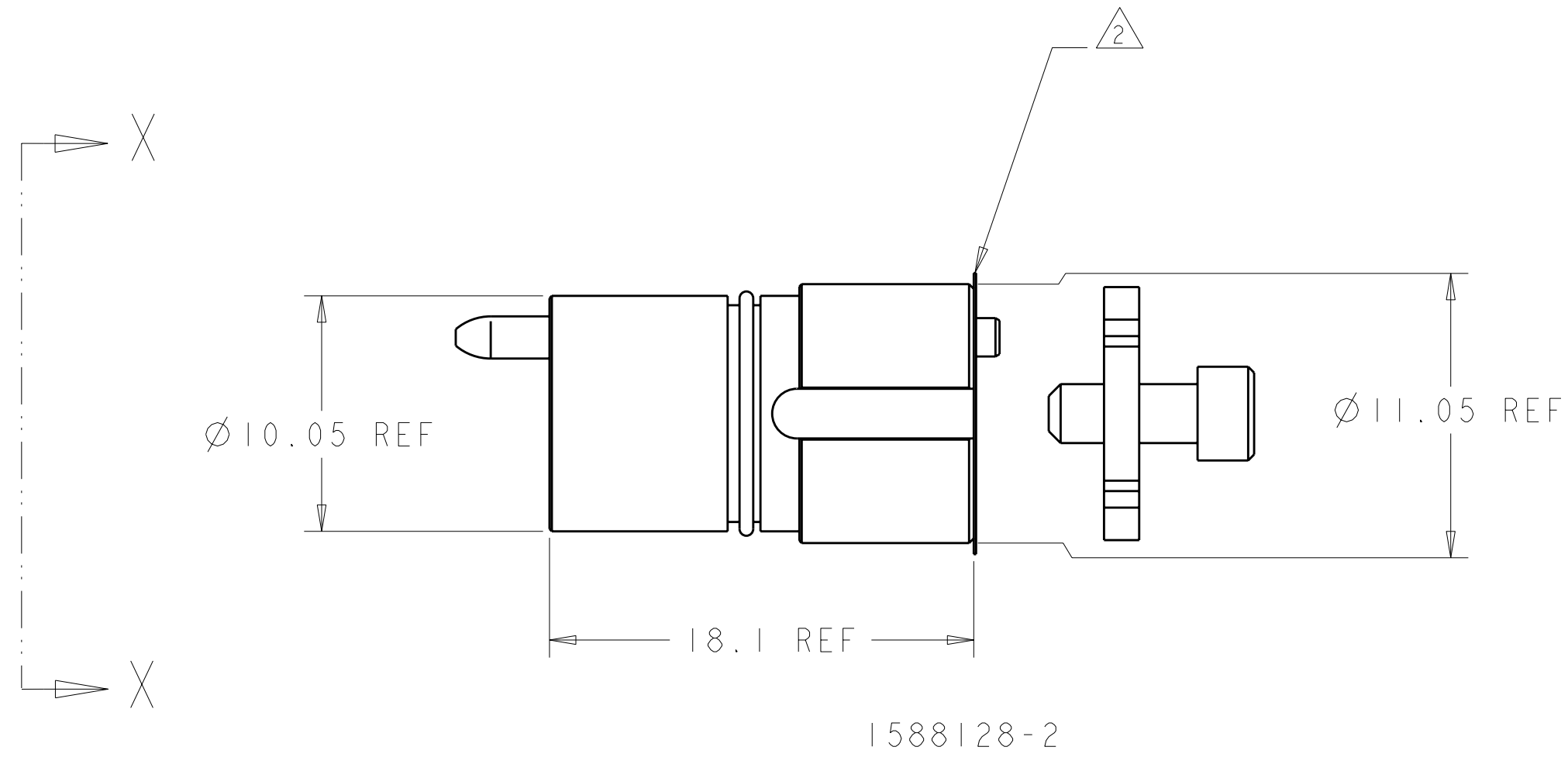

1588128-2/-4

1588128-3/-5

VIEW X - X
 (SHOWN WITHOUT PROTECTIVE LABEL)

DESCRIPTION	PART NUMBER
4 CHANNEL, 1550nm SM	1588128-5
2 CHANNEL, 1550nm SM	1588128-4
4 CHANNEL, 1550nm SM	1588128-3
2 CHANNEL, 1550nm SM	1588128-2
1 CHANNEL, 1550nm SM	1588128-1

6 OBSOLETE

<small>THIS DRAWING IS A CONTROLLED DOCUMENT FOR TYCO ELECTRONICS CORPORATION. IT IS SUBJECT TO CHANGE AND THE CONTROLLING ENGINEERING ORGANIZATION SHOULD BE CONTACTED FOR THE LATEST REVISION.</small>		DWN: K. GLATFELTER 16 APR 2004 CHK: D. WERTMAN 07 JUN 2004 APVD: D. WERTMAN 07 JUN 2004	Tyco Electronics Harrisburg, PA 17105-3608
DIMENSIONS: mm	TOLERANCES UNLESS OTHERWISE SPECIFIED: 0 PLC ± 1 PLC ± 2 PLC ± 3 PLC ± 4 PLC ± ANGLES ± FINISH	PRODUCT SPEC APPLICATION SPEC WEIGHT	NAME: INSERT ASSEMBLY, MINI EB, 1550nm SM SIZE: A2 CAGE CODE: 00779 DRAWING NO: 1588128 RESTRICTED TO: - SCALE: 4:1 SHEET 1 OF 1 REV DI
MATERIAL: STAINLESS ALLOYS & NBR		FINISH: N/A	CUSTOMER DRAWING