



Chipsmall Limited consists of a professional team with an average of over 10 year of expertise in the distribution of electronic components. Based in Hongkong, we have already established firm and mutual-benefit business relationships with customers from,Europe,America and south Asia,supplying obsolete and hard-to-find components to meet their specific needs.

With the principle of “Quality Parts,Customers Priority,Honest Operation,and Considerate Service”,our business mainly focus on the distribution of electronic components. Line cards we deal with include Microchip,ALPS,ROHM,Xilinx,Pulse,ON,Everlight and Freescale. Main products comprise IC,Modules,Potentiometer,IC Socket,Relay,Connector.Our parts cover such applications as commercial,industrial, and automotives areas.

We are looking forward to setting up business relationship with you and hope to provide you with the best service and solution. Let us make a better world for our industry!



Contact us

Tel: +86-755-8981 8866 Fax: +86-755-8427 6832

Email & Skype: info@chipsmall.com Web: www.chipsmall.com

Address: A1208, Overseas Decoration Building, #122 Zhenhua RD., Futian, Shenzhen, China



Hand Held Display (1592 Series)

Plastic



KEY FEATURES

- Ergonomically designed for a comfortable fit into the user's hand.
- Perfect for instrument or mobile data enclosures requiring a keypad and display.
- Available with either a solid display area (1592ETSD) or a versatile opening with a clear lens (1592ETCD).
- Molded in flame retardant ABS plastic, choice of black or grey (material carries a UL flammability rating of 94V-O)
- 1592ETSD offers a solid display area 122 mm x 85 mm (4.8" x 3.4") that will accommodate display boards up to 118 mm x 60 mm (4.6" x 2.37").
- 1592ETCD offers a clear polycarbonate lens 102 mm x 45 mm (4.0" x 1.77") and a plain mylar mask kit allowing for installation of a wide variety of display boards. The lens fits snugly into the case and provides protection from dirt and dust.
- The back of the case has been designed to accept a magnetic strip or velcro mounting tab (see accessories).
- The display area has been insert tooled in order to provide the capability of custom molding a low-cost display area to specific requirements.



Molded in Flame Retardant ABS

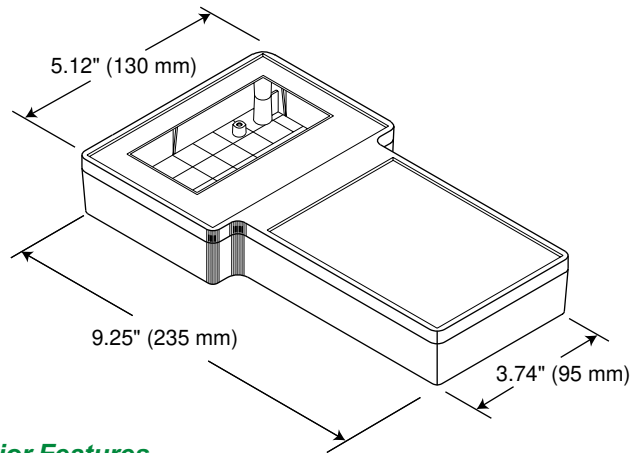
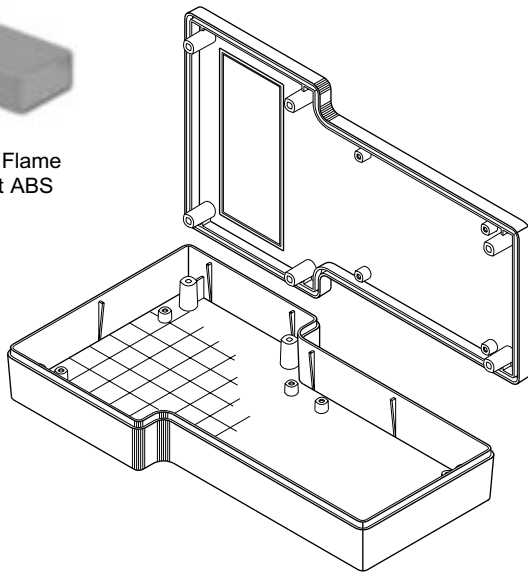

Key Pad Area Features

Has been designed to accept membrane keypads up to 87 mm x 119 mm (3.4" x 4.68"). Insert tooled in order to provide the capability of custom molding a low-cost display area to specific requirements.

Rubber Feet Features

Designed in order to fit into the recessed mounting screw areas to provide both a standoff from the work surface as well as additional sealing from dirt and moisture.

Interior Features

A total of eight mounting bosses have been provided in order to facilitate the use of P.C. cards and other components. These bosses have been strategically placed to provide maximum usable space. A light crosshatch has been provided in order to facilitate layout design. The interior of the lid of the 1592ET has been designed with mounting bosses to facilitate use of displays and other components.

Gasket Features

The 1592ET has been designed to accommodate a gasket, available as accessory part 1592ETG. With proper sealing of the display lens, other modifications and the use of the gasket, the unit will provide protection from dirt, dust and liquids.

Hand Held Display (1592 Series)

Plastic

Lid (Inside & Edge View)

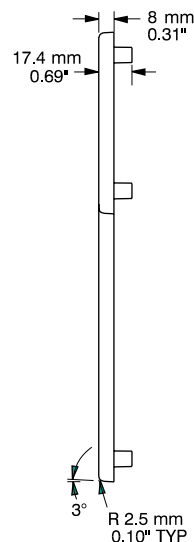
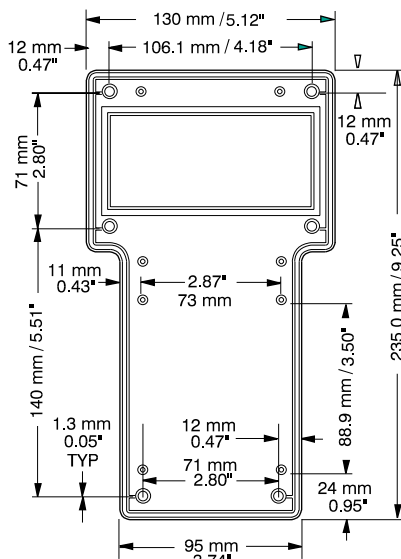

Base (Inside & Edge View)

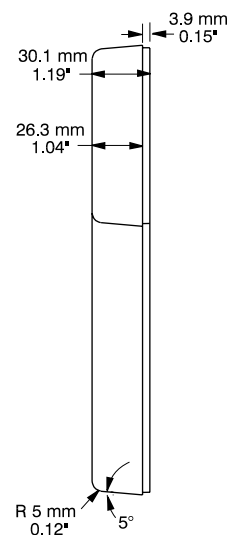
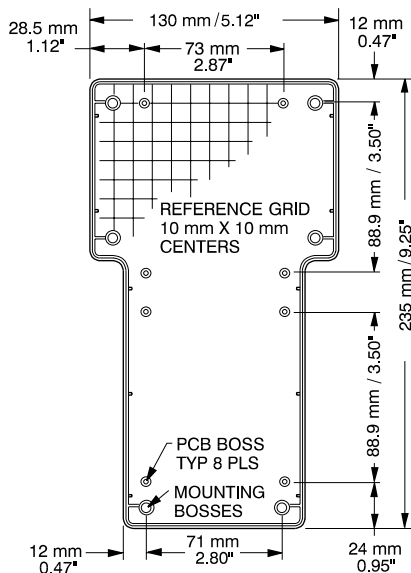

Part Number	Color	Description
1592ETSDGY	Grey	Grey case with solid display area
1592ETSDBK	Black	Black case with solid display area
1592ETCDGY	Grey	Grey case with open display insert and clear polycarbonate lens kit
1592ETCDBK	Black	Black case with open display insert and clear polycarbonate lens kit
1592ETG		Gasket kit with 76 cm (30") of gasket (for one unit)
1592ETRF		Rubber feet (package of 6)
1592ETM		Magnetic strip 7.62 cm (3") square
1592ETV		Velcro mounting tab
1594MS100		M3 - 0.5 x 20mm countersunk flat head replacement screws



CANADA
Guelph, Ontario (519) 822-2960
St. Laurent, Quebec (514) 343-9010
USA
Cheektowaga, NY (716) 651-0086

www.hammondmfg.com

EUROPE
Basingstoke, UK +44 1256 812812

AUSTRALASIA
Queenstown, SA, Australia +61 8 8240 2244