



Chipsmall Limited consists of a professional team with an average of over 10 year of expertise in the distribution of electronic components. Based in Hongkong, we have already established firm and mutual-benefit business relationships with customers from,Europe,America and south Asia,supplying obsolete and hard-to-find components to meet their specific needs.

With the principle of “Quality Parts,Customers Priority,Honest Operation,and Considerate Service”,our business mainly focus on the distribution of electronic components. Line cards we deal with include Microchip,ALPS,ROHM,Xilinx,Pulse,ON,Everlight and Freescale. Main products comprise IC,Modules,Potentiometer,IC Socket,Relay,Connector.Our parts cover such applications as commercial,industrial, and automotives areas.

We are looking forward to setting up business relationship with you and hope to provide you with the best service and solution. Let us make a better world for our industry!



Contact us

Tel: +86-755-8981 8866 Fax: +86-755-8427 6832

Email & Skype: info@chipsmall.com Web: www.chipsmall.com

Address: A1208, Overseas Decoration Building, #122 Zhenhua RD., Futian, Shenzhen, China



Enclosures can be Factory Modified (Milling, Drilling, Printing etc.)
 Contact Factory mjm@hammondmfg.com for quotes

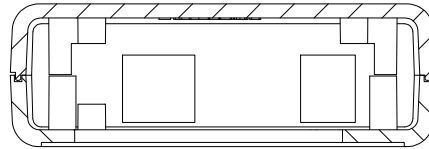

SECTION B-B

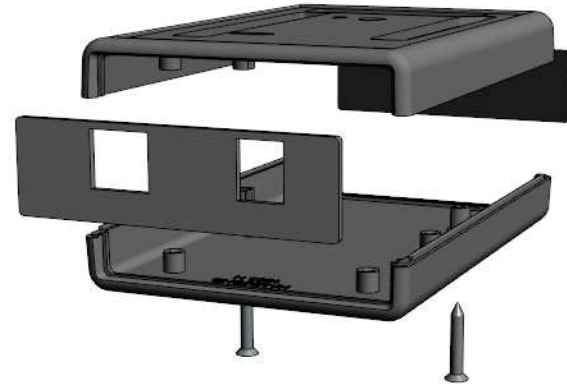
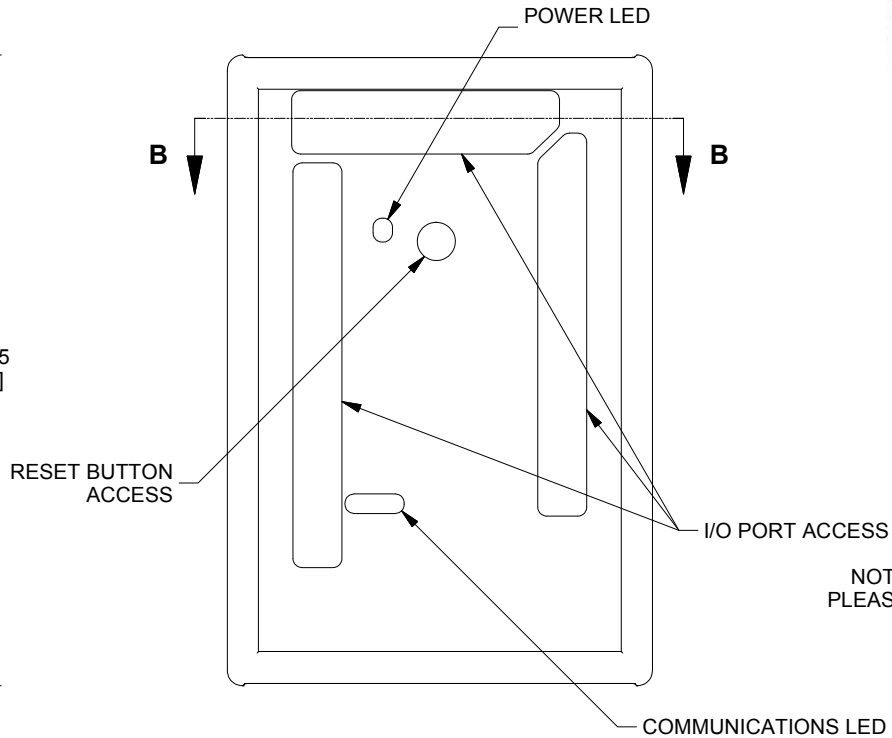
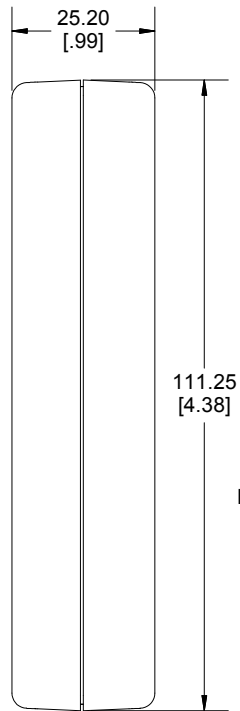

NOTE: 1593MEG ENCLOSURE IS BASED ON HAMMOND STANDARD 1593N
 PLEASE SEE 1593N DRAWING FOR STANDARD ENCLOSURE SPECIFICATIONS

NOTE

Purchased assembly includes top and bottom cover, front and rear end panels, 2 cover screws, and 1 black rubber foot (P.C. Board not included)
 Enclosure molded from ABS Plastic.

ASSEMBLY - VIEW FROM TOP SIDE

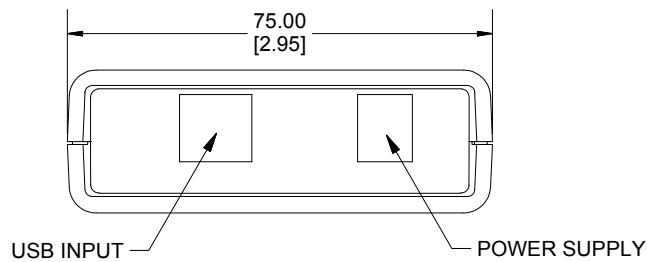

PART NUMBERS

1593HAMMEG Enclosure	
Black Enclosure	1593HAMMEGBK
Grey Enclosure	1593HAMMEGGY
Translucent Blue Enclosure	1593HAMMEGTBU

Dimensions:
 mm
 [inches]



**HAMMOND
 MANUFACTURING™**
1593HAMMEG
www.hammondmfg.com