



Chipsmall Limited consists of a professional team with an average of over 10 year of expertise in the distribution of electronic components. Based in Hongkong, we have already established firm and mutual-benefit business relationships with customers from,Europe,America and south Asia,supplying obsolete and hard-to-find components to meet their specific needs.

With the principle of “Quality Parts,Customers Priority,Honest Operation,and Considerate Service”,our business mainly focus on the distribution of electronic components. Line cards we deal with include Microchip,ALPS,ROHM,Xilinx,Pulse,ON,Everlight and Freescale. Main products comprise IC,Modules,Potentiometer,IC Socket,Relay,Connector.Our parts cover such applications as commercial,industrial, and automotives areas.

We are looking forward to setting up business relationship with you and hope to provide you with the best service and solution. Let us make a better world for our industry!



Contact us

Tel: +86-755-8981 8866 Fax: +86-755-8427 6832

Email & Skype: info@chipsmall.com Web: www.chipsmall.com

Address: A1208, Overseas Decoration Building, #122 Zhenhua RD., Futian, Shenzhen, China



Draft Angle of
Approximately 1°

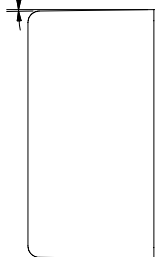

Side View of Box

M3x0.5 - 6H ∇ 5.75
Threaded Holes

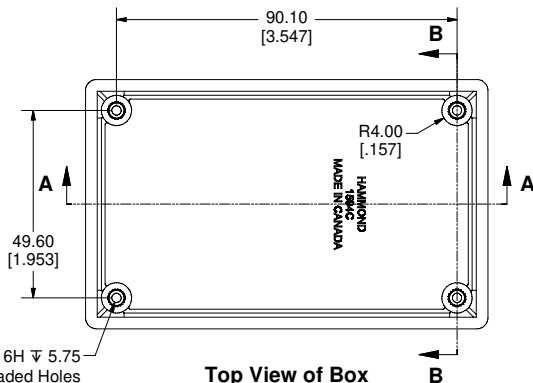

Top View of Box

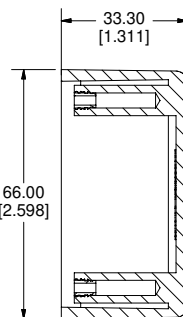

SECTION B-B
SCALE 1 : 1

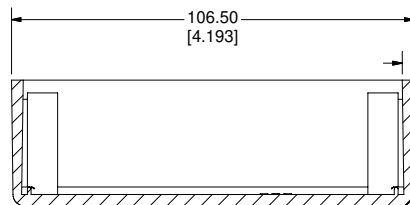

SECTION A-A
SCALE 1 : 1

Average Wall Thickness
3.10
[.12]

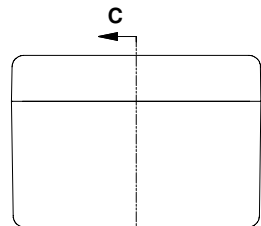

End View of Assembly

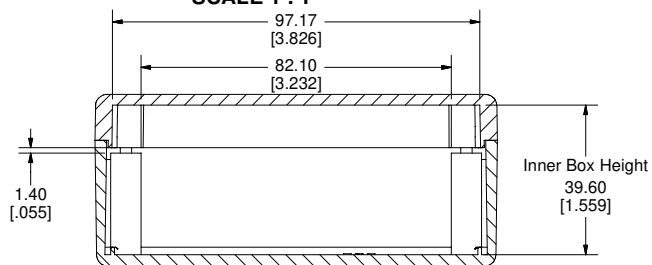

SECTION C-C
SCALE 1 : 1

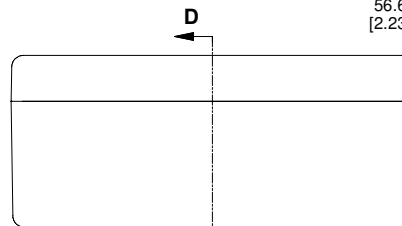

Side View of Assembly

Narrowest Inside Dimension
56.67
[2.231]

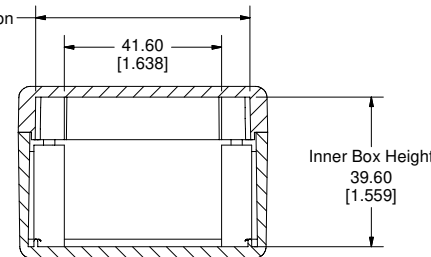

SECTION D-D
SCALE 1 : 1

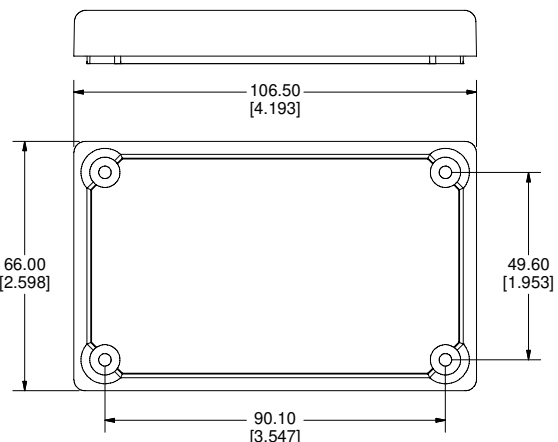

Bottom of Lid

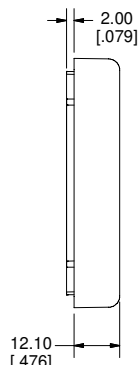

Side of Lid

1594C Enclosure	
FLAME RETARDANT ABS	
Black - RAL 9011	1594CBK
Grey - RAL 7018	1594CGY
NON-FLAME RETARDANT ABS	
Grey - RAL 7035	1594CSGY
Black - RAL 9011	1594CSBK
LIQUID RESISTANT	
Black - RAL 9011	1594CWBK
ACCESSORIES	
Cover Screws Non-Flame Retardant (pkg. 100) [#4 x 1" Self-Tapping]	1594TS100
Cover Screws Flame Retardant (pkg. 100) [M3 - 0.5 x 20mm]	1594MS100
Cover Screws Liquid Resistant (pkg. 100) [M3 - 0.5 x 20mm]	1594WMS100
Circuit Board Holders	(See 1594Z Series)

Enclosures can be Factory Modified (Milling, Drilling, Printing etc.)
Solid models of this enclosure available in STEP or IGES.
Contact Factory mjm@hammondmfg.com

