



Chipsmall Limited consists of a professional team with an average of over 10 year of expertise in the distribution of electronic components. Based in Hongkong, we have already established firm and mutual-benefit business relationships with customers from,Europe,America and south Asia,supplying obsolete and hard-to-find components to meet their specific needs.

With the principle of “Quality Parts,Customers Priority,Honest Operation,and Considerate Service”,our business mainly focus on the distribution of electronic components. Line cards we deal with include Microchip,ALPS,ROHM,Xilinx,Pulse,ON,Everlight and Freescale. Main products comprise IC,Modules,Potentiometer,IC Socket,Relay,Connector.Our parts cover such applications as commercial,industrial, and automotives areas.

We are looking forward to setting up business relationship with you and hope to provide you with the best service and solution. Let us make a better world for our industry!



## Contact us

Tel: +86-755-8981 8866 Fax: +86-755-8427 6832

Email & Skype: info@chipsmall.com Web: www.chipsmall.com

Address: A1208, Overseas Decoration Building, #122 Zhenhua RD., Futian, Shenzhen, China



### Bottom View of Assembly

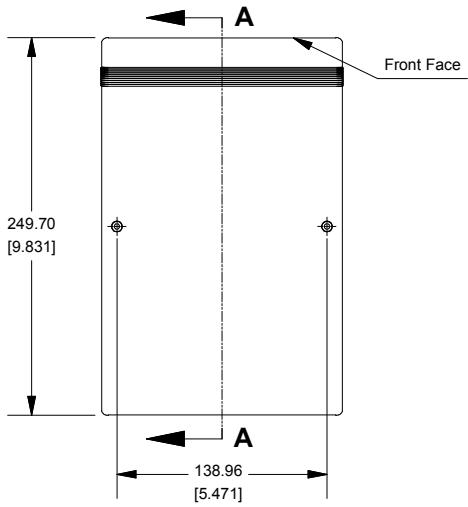

### SECTION A-A (Side View Inside Assembly)

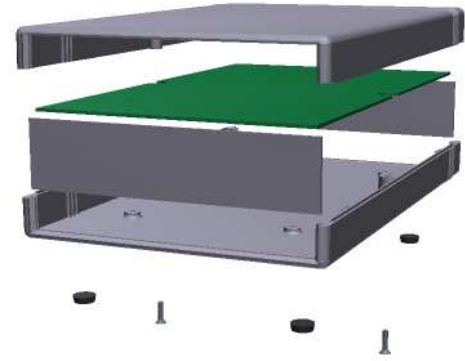
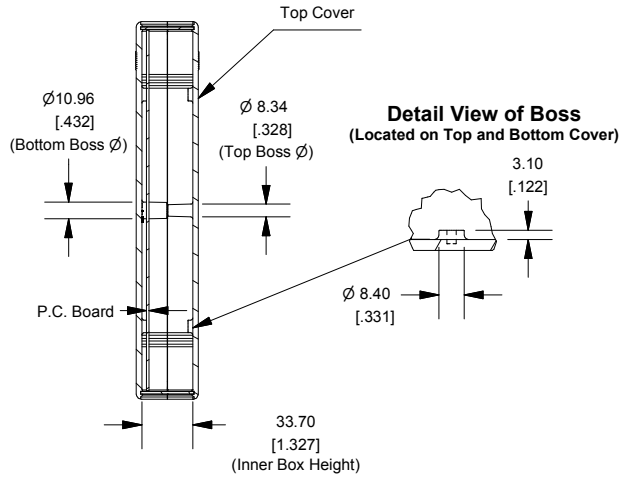

### End View of Assembly

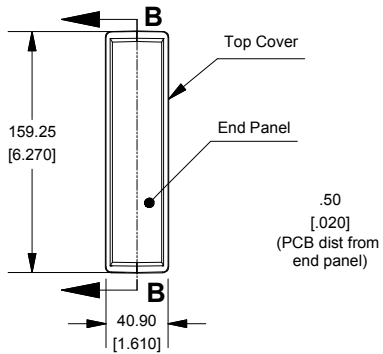

### SECTION B-B (Inside of Bottom Cover)

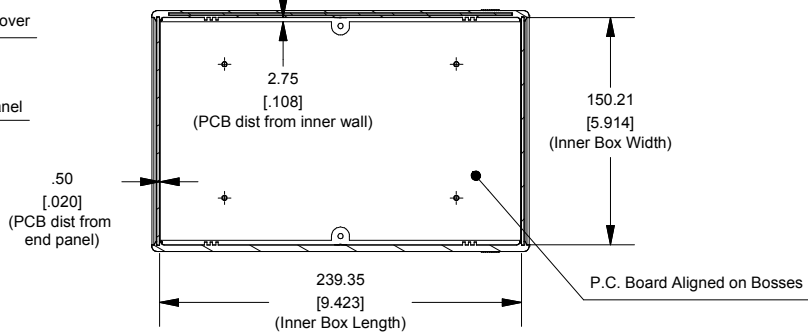

### Front/Rear Panel (Dashed Line Indicates Viewing Area)

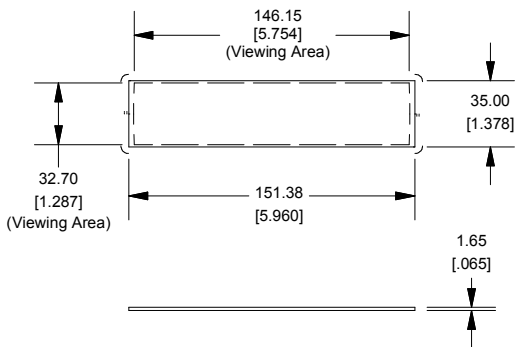

### Maximum P.C. Board Size

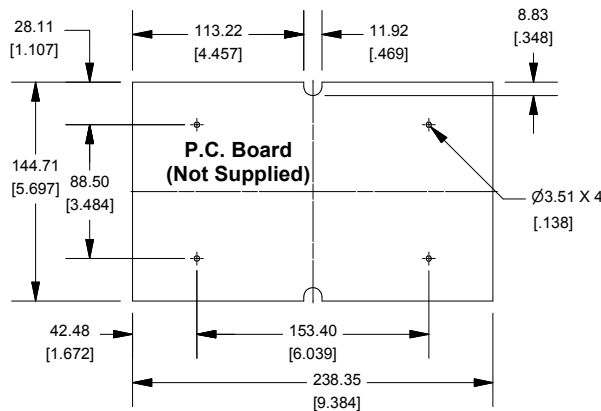

Enclosures can be Factory Modified ( Milling, Drilling, Printing etc. )  
Solid models of this enclosure available in STEP or IGES.  
Contact Factory [mjm@hammondmfg.com](mailto:mjm@hammondmfg.com)

#### NOTE

Purchased Assembly includes top and bottom cover, front and end aluminum panels (alloy 5052-H32, SPV coating on one side), 2 cover screws, and 4 rubber feet.

#### 1598F Instrument Case

FLAME RETARDANT ABS (UL94-VO)

|                                      |          |
|--------------------------------------|----------|
| Black Enclosure with Aluminum Panels | 1598FBK  |
| Grey Enclosure with Aluminum Panels  | 1598FGY  |
| Black EMI/RFI Shielded               | 1598RFBK |

NON-FLAME RETARDANT GPABS (UL94-HB)

|  |             |
|--|-------------|
| Grey Enclosure with Aluminum Panels      | 1598FSGY    |
| Grey Enclosure with Black Plastic Panels | 1598FSGYPBK |

#### ACCESSORIES

|   |            |
|---|------------|
| Black Plastic Panels                        | 1598PLFBK  |
| Rubber Feet (Pkg 24)                        | 1421T2     |
| For 1598 FR-ABS                             |            |
| Cover Screws (Pkg 100) [M3 - 0.5 x 10mm]    | 1591MS100  |
| For 1598 GPABS                              |            |
| Cover Screws (Pkg 100) [#4 x 5/8" (15.9mm)] | 1591TS100  |
| For Both Models                             |            |
| PCB Screws (Pkg 100) [#6 x 1/4" (6.4mm)]    | 1598ATS100 |

