



Chipsmall Limited consists of a professional team with an average of over 10 year of expertise in the distribution of electronic components. Based in Hongkong, we have already established firm and mutual-benefit business relationships with customers from,Europe,America and south Asia,supplying obsolete and hard-to-find components to meet their specific needs.

With the principle of “Quality Parts,Customers Priority,Honest Operation,and Considerate Service”,our business mainly focus on the distribution of electronic components. Line cards we deal with include Microchip,ALPS,ROHM,Xilinx,Pulse,ON,Everlight and Freescale. Main products comprise IC,Modules,Potentiometer,IC Socket,Relay,Connector.Our parts cover such applications as commercial,industrial, and automotives areas.

We are looking forward to setting up business relationship with you and hope to provide you with the best service and solution. Let us make a better world for our industry!



## Contact us

Tel: +86-755-8981 8866 Fax: +86-755-8427 6832

Email & Skype: info@chipsmall.com Web: www.chipsmall.com

Address: A1208, Overseas Decoration Building, #122 Zhenhua RD., Futian, Shenzhen, China



**Bottom View of Assembly**

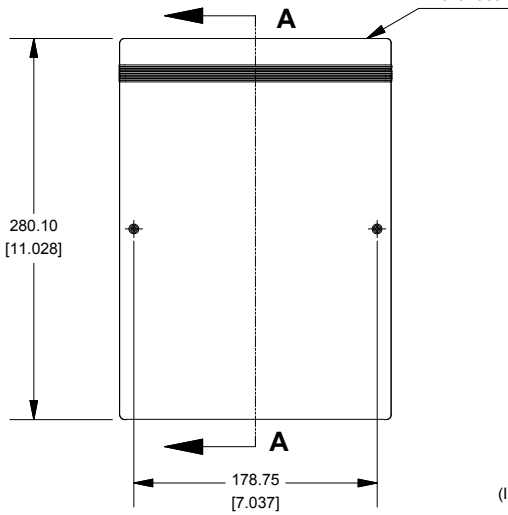

**SECTION A-A  
(Side View Inside Assembly)**

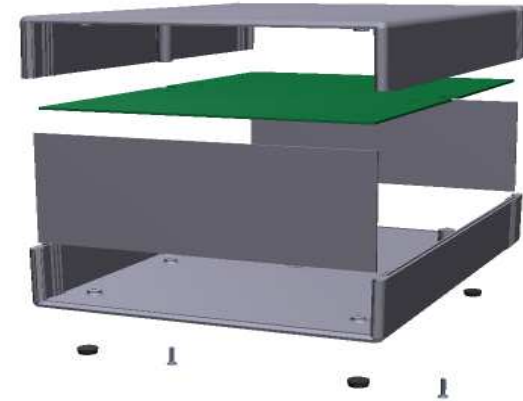
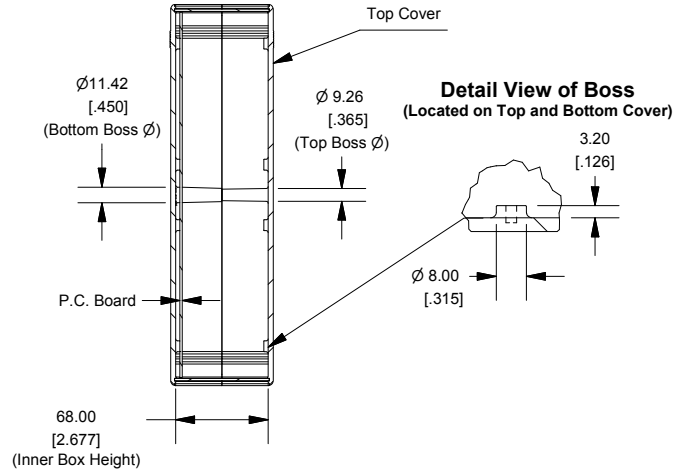

**End View of Assembly**

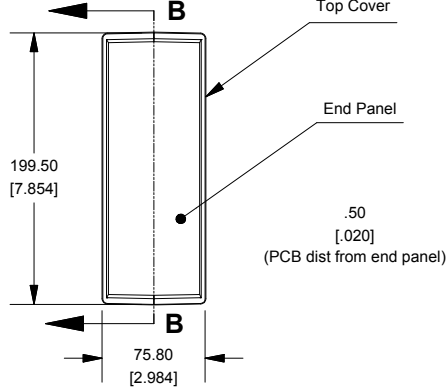

**SECTION B-B  
(Inside of Bottom Cover)**

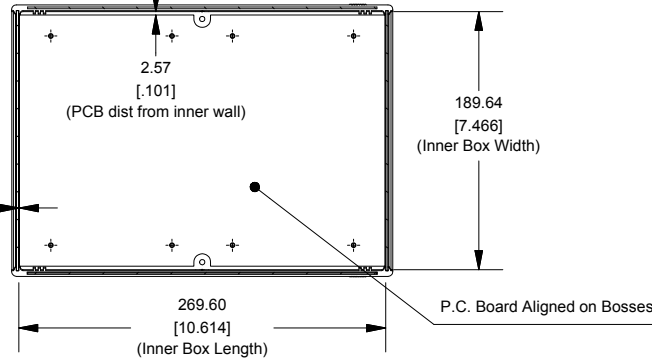

Enclosures can be Factory Modified ( Milling, Drilling, Printing etc. )  
Solid models of this enclosure available in STEP or IGES.  
Contact Factory [mjm@hammondmfg.com](mailto:mjm@hammondmfg.com)

**NOTE**

Purchased Assembly includes top and bottom cover, front and end aluminum panels (alloy 5052-H32, SPV coating on one side), 2 cover screws, and 4 rubber feet.

<b>1598J Instrument Case</b>	
<b>FLAME RETARDANT ABS (UL94-VO)</b>	
Black Enclosure with Aluminum Panels	1598JBK
Grey Enclosure with Aluminum Panels	1598JGY
Black EMI/RFI Shielded	1598RJBK
<b>NON-FLAME RETARDANT GPABS (UL94-HB)</b>	
Grey Enclosure with Aluminum Panels	1598JSGY
Grey Enclosure with Black Plastic Panels	1598JSGYPBK
<b>ACCESSORIES</b>	
Black Plastic Panels	1598PLJBK
Rubber Feet (Pkg 24)	1421T2
For 1598 FR-ABS	
Cover Screws (Pkg 100) [M3 - 0.5 x 10mm]	1591MS100
For 1598 GPABS	
Cover Screws (Pkg 100) [#4 x 5/8" (15.9mm)]	1591TS100
For Both Models	
PCB Screws (Pkg 100) [#6 x 1/4" (6.4mm)]	1598ATS100

**Front/Rear Panel  
(Dashed Line Indicates Viewing Area)**

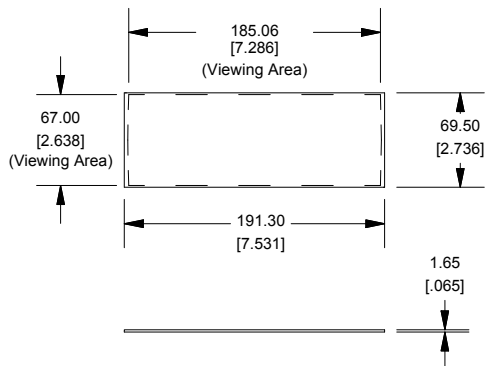

**Maximum P.C. Board Size**

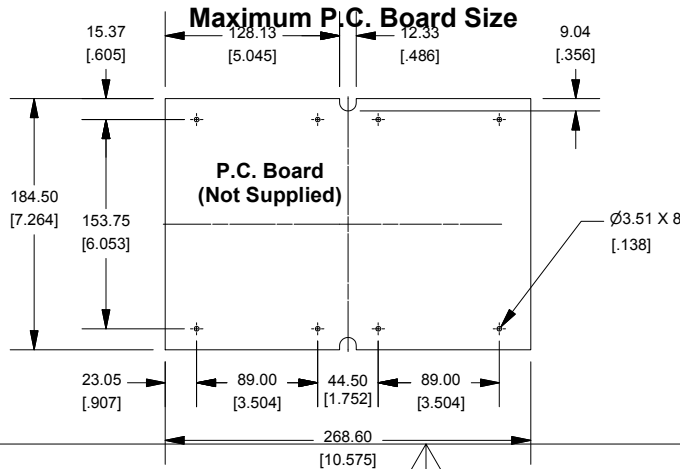

**HAMMOND  
MANUFACTURING™**

**1598J**

[www.hammondmfg.com](http://www.hammondmfg.com)