



Chipsmall Limited consists of a professional team with an average of over 10 year of expertise in the distribution of electronic components. Based in Hongkong, we have already established firm and mutual-benefit business relationships with customers from,Europe,America and south Asia,supplying obsolete and hard-to-find components to meet their specific needs.

With the principle of "Quality Parts,Customers Priority,Honest Operation,and Considerate Service",our business mainly focus on the distribution of electronic components. Line cards we deal with include Microchip,ALPS,ROHM,Xilinx,Pulse,ON,Everlight and Freescale. Main products comprise IC,Modules,Potentiometer,IC Socket,Relay,Connector.Our parts cover such applications as commercial,industrial, and automotives areas.

We are looking forward to setting up business relationship with you and hope to provide you with the best service and solution. Let us make a better world for our industry!



Contact us

Tel: +86-755-8981 8866 Fax: +86-755-8427 6832

Email & Skype: info@chipsmall.com Web: www.chipsmall.com

Address: A1208, Overseas Decoration Building, #122 Zhenhua RD., Futian, Shenzhen, China



A set consists of:

2x connection bolt
2x locking plate

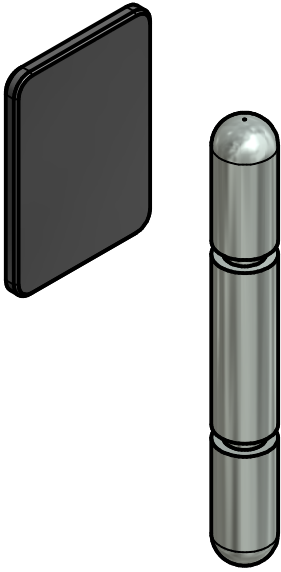

Connection bolt

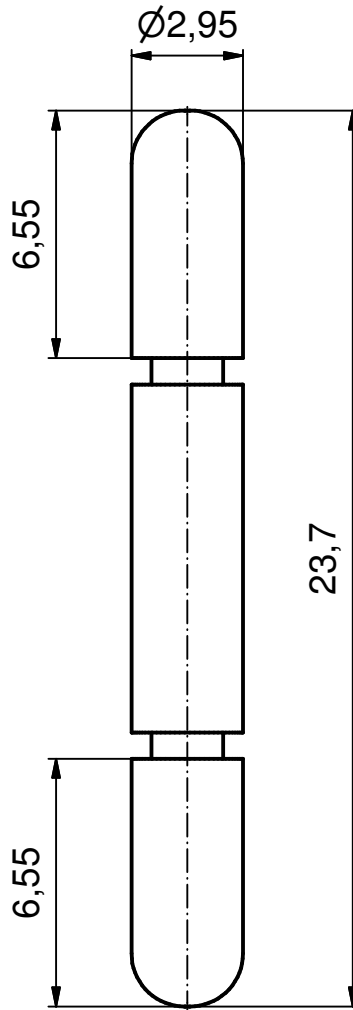

Locking plate

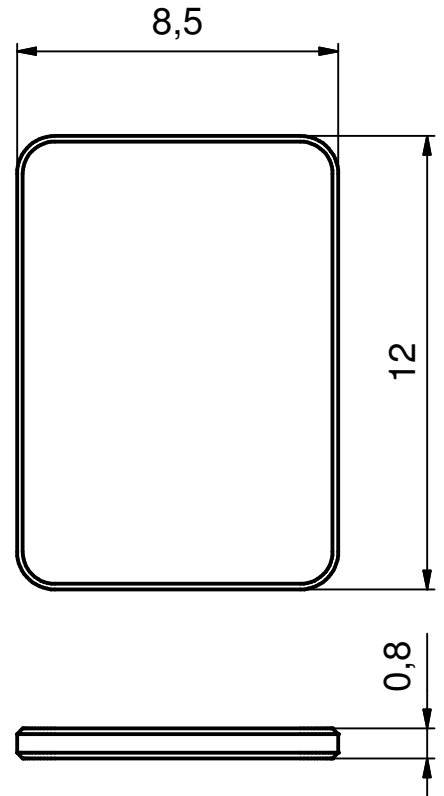



RoHS compliant

NOTES:

1. Connection bolt: Steel; Nickel plated
2. Locking plate: ABS UL94 V-0, black

THIS DRAWING MAY NOT BE COPIED OR REPRODUCED IN ANY WAY, AND MAY NOT BE PASSED ON TO A THIRD PARTY WITHOUT WRITTEN PERMISSION. OWNERSHIP AND COPYRIGHT OF CONEC GmbH

DO NOT ALTER CAD DRAWING BY HAND

				tolerance ISO 2768-m	 dim. in mm
				date	name
				drawn 02.02.15	Henneboel
				appd. 02.02.15	Strakerjahn
				norm	
				d-old	
					
a	Original				
rev.	description	date	name		

scale:		5:1 (3:1)
material:		see notes
title: Kit Encoding Connection f. Hood Snap Lock Kit Kodier-Rastbolzen		
dwg no:		DIN-A4
16K1A3583		sh: 1
part no:		16-002200