



Chipsmall Limited consists of a professional team with an average of over 10 year of expertise in the distribution of electronic components. Based in Hongkong, we have already established firm and mutual-benefit business relationships with customers from,Europe,America and south Asia,supplying obsolete and hard-to-find components to meet their specific needs.

With the principle of “Quality Parts,Customers Priority,Honest Operation,and Considerate Service”,our business mainly focus on the distribution of electronic components. Line cards we deal with include Microchip,ALPS,ROHM,Xilinx,Pulse,ON,Everlight and Freescale. Main products comprise IC,Modules,Potentiometer,IC Socket,Relay,Connector.Our parts cover such applications as commercial,industrial, and automotives areas.

We are looking forward to setting up business relationship with you and hope to provide you with the best service and solution. Let us make a better world for our industry!



Contact us

Tel: +86-755-8981 8866 Fax: +86-755-8427 6832

Email & Skype: info@chipsmall.com Web: www.chipsmall.com

Address: A1208, Overseas Decoration Building, #122 Zhenhua RD., Futian, Shenzhen, China



THIS DRAWING IS UNPUBLISHED. RELEASED FOR PUBLICATION
 © COPYRIGHT BY TYCO ELECTRONICS CORPORATION. ALL RIGHTS RESERVED.

LOC	DIST	REVISIONS			
P	LTR	DESCRIPTION	DATE	DWN	APVD
AF	50				
F2		REVISED PER ECR-08-005455	06MAR08	HMR	GJ
F3		REVISED PER ECO-09-024606	28OCT09	KK	AEG

- 1 SPECIFICATIONS:
MAGNET WIRE #18 - #34 AWG,
1.02MM(.040")-0.16MM(.006") DIA COPPER.
- 2 POCKET RECOMMENDATION: #1601424
- 3 TERMINAL APPLICATION TO COMPLY WITH TYCO
ELECTRONICS SPECIFICATION 114-13166 FIGURE 5
- 4 POST TIN PLATE .000120-.000200 THK
OVER .000050 MIN THK NICKEL
- 5 OBSOLETE PARTS: OBSOLETE CIS STREAMLINING PER D.RENAUD/D.SINISI

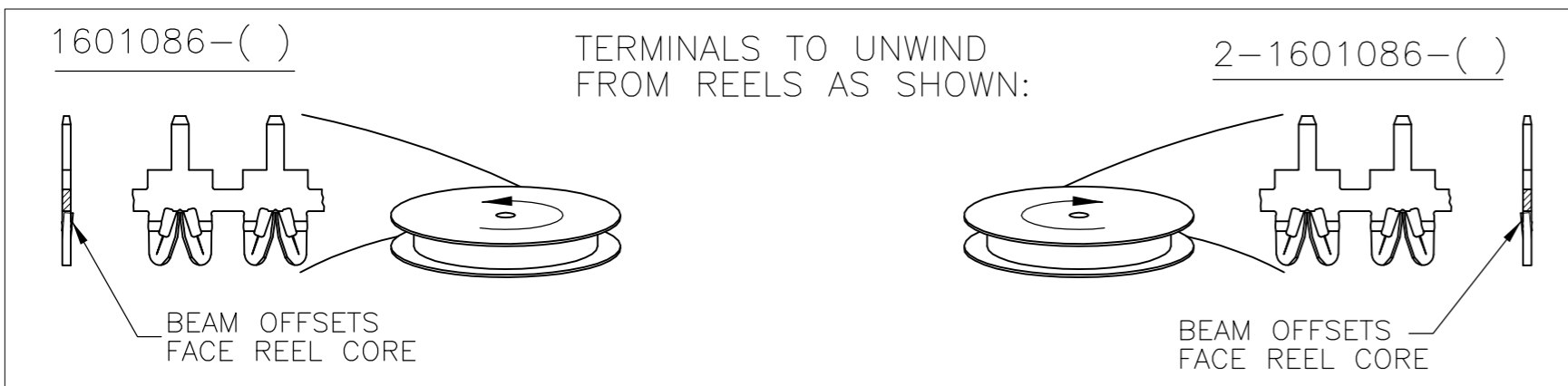
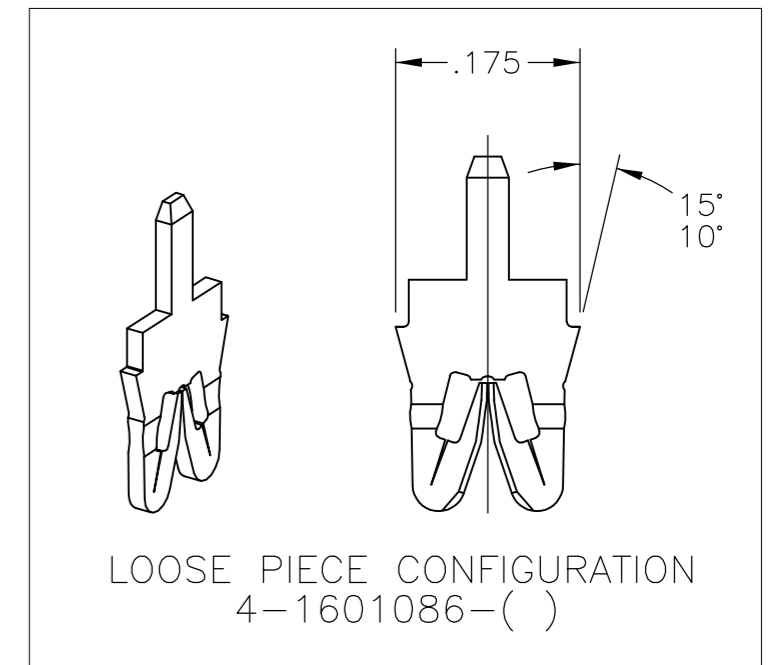
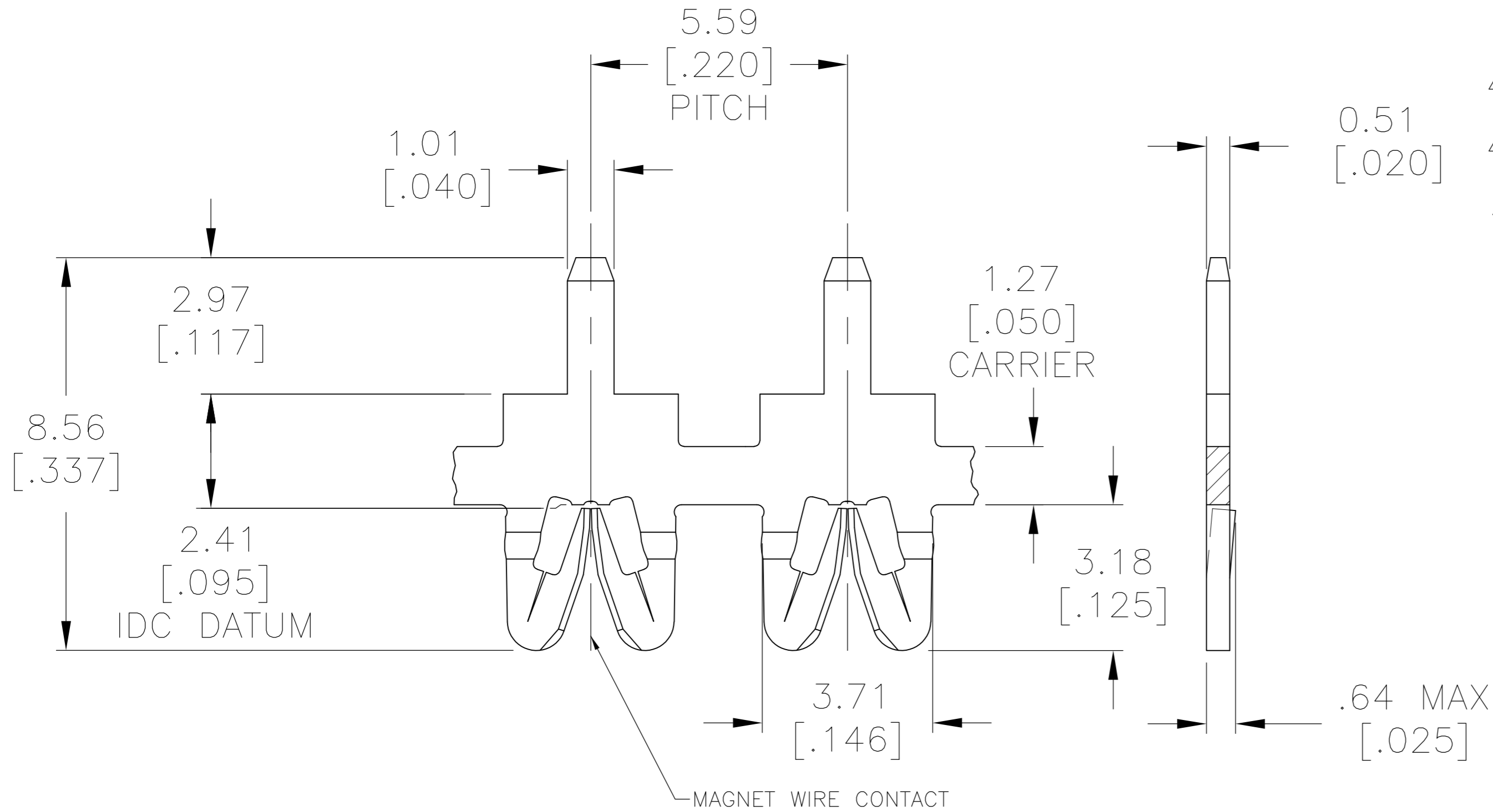

	TIN OVER NICKEL 4	-	4-1601086-3
	TIN OVER NICKEL 4	-	1601086-3
OBSOLETE	Unplated	131-158-000	2-1601086-1
SUPERSEDED BY 1601086-3	Post Tin Lead Plate over Copper Underplate	131-157-024	1601086-2
OBSOLETE	Unplated	131-157-000	1601086-1
FINISH		REFERENCE PART NUMBER	PART NUMBER
THIS DRAWING IS A CONTROLLED DOCUMENT.		Tyco Electronics Corporation Harrisburg, PA 17105-3608	
DOWNSIDE: J.WELLER 11JAN2002 CHECKED: M.FEHER 11JAN2002 APPROVED: K.RANDOLPH 11JAN2002		NAME: STANDARD RANGE WIRE TO .117 P.C. BOARD SIAMEZE TERMINAL	
DIMENSIONS: mm [INCHES]	TOLERANCES UNLESS OTHERWISE SPECIFIED: 0 PLC ± - 1 PLC ± 0.25 [.010] 2 PLC ± 0.13 [.005] 3 PLC ± - 4 PLC ± - ANGLES ± 2°	SIZE: A2	CAGE CODE: 00779
MATERIAL: BRASS, SPRING HARD	FINISH: SEE TABLE	WEIGHT: -	DRAWING NO: C=1601086
CUSTOMER DRAWING		SCALE: 11:1	SHEET: 1 OF 1
		REV: F3	