



Chipsmall Limited consists of a professional team with an average of over 10 year of expertise in the distribution of electronic components. Based in Hongkong, we have already established firm and mutual-benefit business relationships with customers from,Europe,America and south Asia,supplying obsolete and hard-to-find components to meet their specific needs.

With the principle of “Quality Parts,Customers Priority,Honest Operation,and Considerate Service”,our business mainly focus on the distribution of electronic components. Line cards we deal with include Microchip,ALPS,ROHM,Xilinx,Pulse,ON,Everlight and Freescale. Main products comprise IC,Modules,Potentiometer,IC Socket,Relay,Connector.Our parts cover such applications as commercial,industrial, and automotives areas.

We are looking forward to setting up business relationship with you and hope to provide you with the best service and solution. Let us make a better world for our industry!



## Contact us

Tel: +86-755-8981 8866 Fax: +86-755-8427 6832

Email & Skype: info@chipsmall.com Web: www.chipsmall.com

Address: A1208, Overseas Decoration Building, #122 Zhenhua RD., Futian, Shenzhen, China



LOC		DIST		REVISIONS			
AF	50	REV	DATE	BY	CHK	APPV	
A4		REVISED PER ECR-12-000651	18JAN12	KH	GJ		

- 1 SPECIFICATION: WIRE RANGE; #18-#34 AWG. 0.16-1.02 mm [.006-.040] DIA. COPPER MAGNET WIRE.
- 2 POCKET RECOMMENDATION: 1601425 EXCEPT 7.61 [.300] HIGH, ALTERNATE POCKET 1601431
- 3 TERMINAL APPLICATION TO COMPLY WITH TYCO ELECTRONICS SPEC 114-13166, CONSULT TYCO ELECTRONICS PRODUCT ENGINEERING FOR PROPER INSERTION DEPTH.
- 4 POST PLATED TIN OVER COPPER
- 5 2 TERMINALS SHOWN FOR ILLUSTRATION PURPOSES.
- 6 NON-STANDARD PACKAGING. REEL WITH FLUTED PLASTIC FLANGES AND PAPER CORE PAPER INTERLEAVING. PLACED IN A PLASTIC BAG. REDUCED QUANTITY PER REEL.
- 7 NON-STANDARD PACKAGING. ALL PLASTIC REEL PLASTIC INTERLEAVING. PLACED IN A PLASTIC BAG.
- 8 NON-STANDARD DOUBLE BAG.
- 9 PRELIMINARY - NOT FOR PRODUCTION.

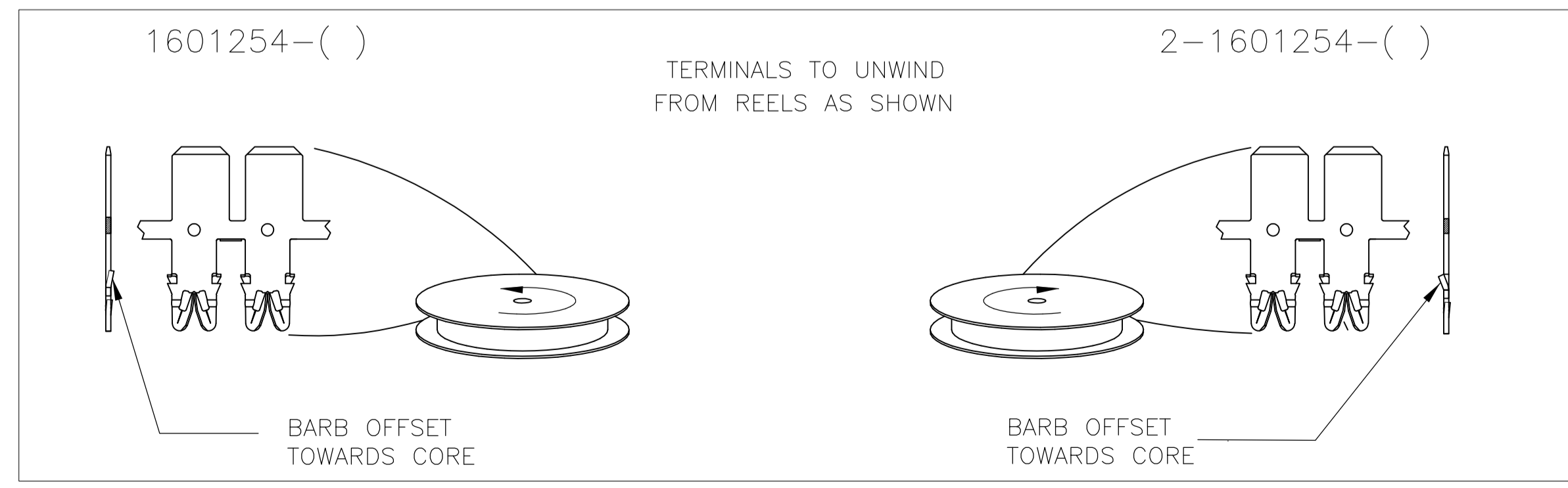
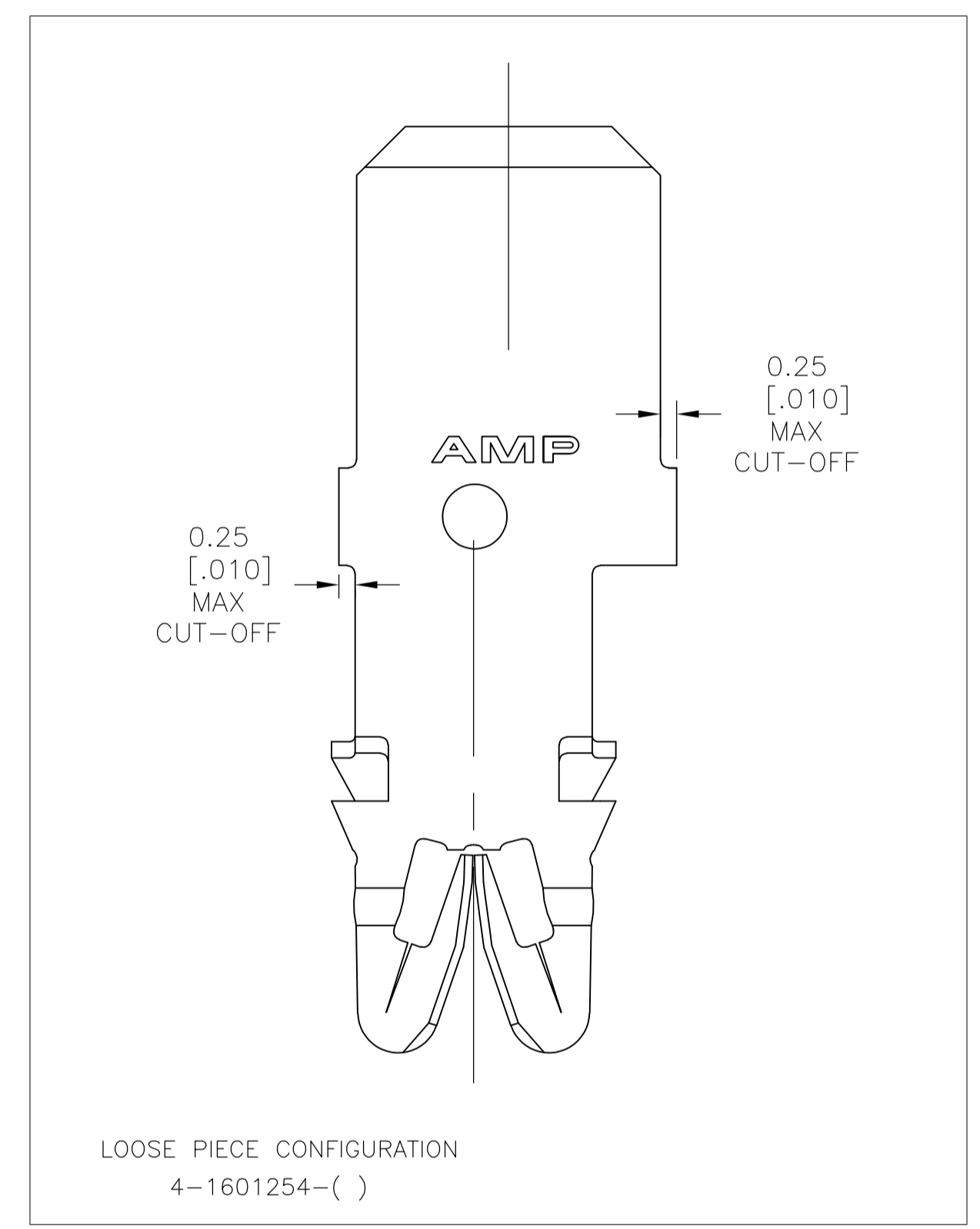
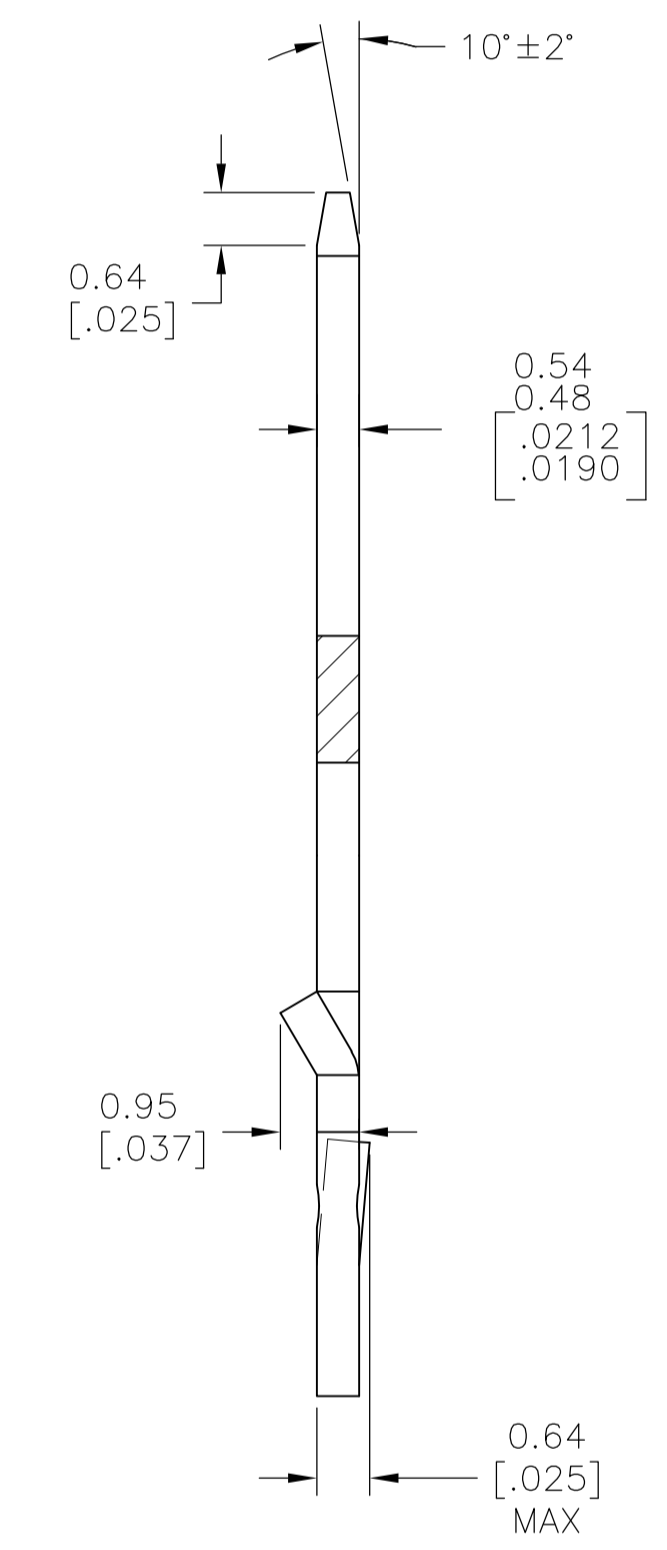
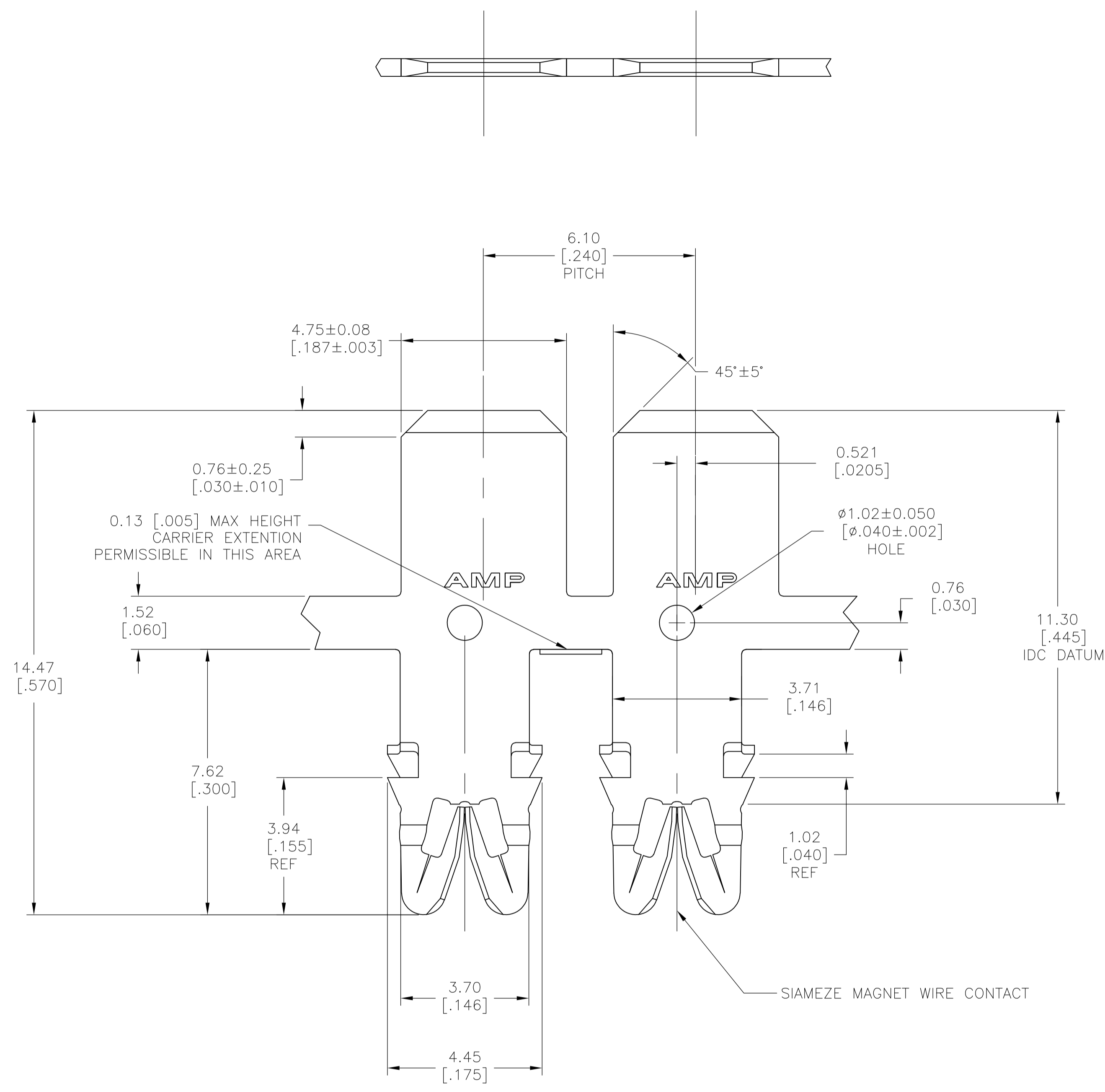

8	9	4-1601254-2
7		1601254-4
6	9	1601254-3
STANDARD		1601254-2
PACKAGING		PART NUMBER

THIS DRAWING IS A CONTROLLED DOCUMENT.		DWN RAGHAVENDRA 10JUN09	STE TE Connectivity	
DIMENSIONS: mm [INCHES]		CHK G. JACONO 10JUN09	NAME	
TOLERANCES UNLESS OTHERWISE SPECIFIED:		APPV G. JACONO 10JUN09	PRODUCT SPEC	
0. PLC ± -	1. PLC ± -	APPLICATION SPEC		
2. PLC ± 0.13 [.005]	3. PLC ± -	108-2085		
4. PLC ± -	ANGLES ± °	SIZE CAGE CODE DRAWING NO		
MATERIAL FULL HARD BRASS	FINISH 4	WEIGHT -	A1 00779	1601254
CUSTOMER DRAWING		SCALE 11:1	SHEET 1 of 1	REV A4