



Chipsmall Limited consists of a professional team with an average of over 10 year of expertise in the distribution of electronic components. Based in Hongkong, we have already established firm and mutual-benefit business relationships with customers from,Europe,America and south Asia,supplying obsolete and hard-to-find components to meet their specific needs.

With the principle of “Quality Parts,Customers Priority,Honest Operation,and Considerate Service”,our business mainly focus on the distribution of electronic components. Line cards we deal with include Microchip,ALPS,ROHM,Xilinx,Pulse,ON,Everlight and Freescale. Main products comprise IC,Modules,Potentiometer,IC Socket,Relay,Connector.Our parts cover such applications as commercial,industrial, and automotives areas.

We are looking forward to setting up business relationship with you and hope to provide you with the best service and solution. Let us make a better world for our industry!



Contact us

Tel: +86-755-8981 8866 Fax: +86-755-8427 6832

Email & Skype: info@chipsmall.com Web: www.chipsmall.com

Address: A1208, Overseas Decoration Building, #122 Zhenhua RD., Futian, Shenzhen, China



| LOC | | DIST | | REVISIONS | | | |
|-----|---------------------------|---------|-----|-----------|--|--|--|
| FP | LTR | DATE | DMN | APVD | | | |
| A1 | REVISED PER ECR-12-007322 | 20APR12 | KH | GJ | | | |

- 1 SPECIFICATION: WIRE RANGE; #18-#34 AWG. 0.16-1.02 mm [.006-.040] DIA. COPPER MAGNET WIRE.
- 2 POCKET RECOMMENDATION: 1601425 EXCEPT 7.61 [.300] HIGH, ALTERNATE POCKET 1601431
- 3 TERMINAL APPLICATION TO COMPLY WITH TYCO ELECTRONICS SPEC 114-13166, CONSULT TYCO ELECTRONICS PRODUCT ENGINEERING FOR PROPER INSERTION DEPTH.
- 4 POST PLATED TIN OVER COPPER
- 5 2 TERMINALS SHOWN FOR ILLUSTRATION PURPOSES.
- 6 NON-STANDARD PACKAGING. REDUCED QUANTITY. REEL WITH FLUTED PLASTIC FLANGES AND PAPER CORE. PAPER INTERLEAVING. PLACED IN A PLASTIC BAG.
- 7 NON-STANDARD PACKAGING. ALL PLASTIC REEL. PLASTIC INTERLEAVING. PLACED IN A PLASTIC BAG.
- 8 NON-STANDARD DOUBLE BAG.
- 9 PRELIMINARY - NOT FOR PRODUCTION

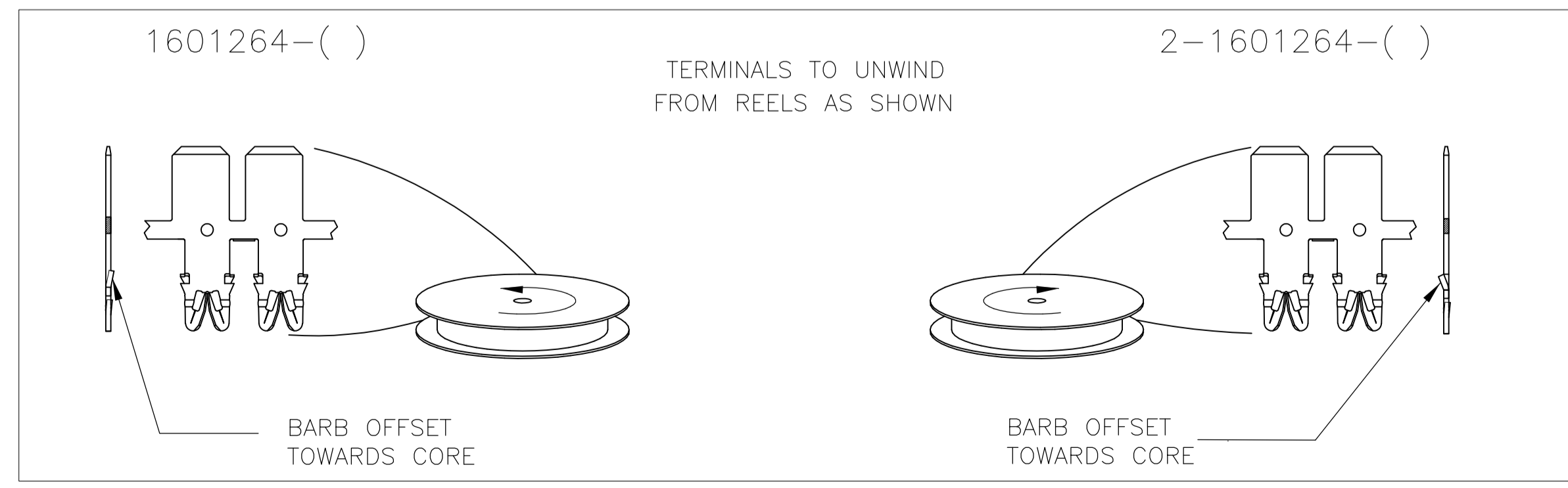
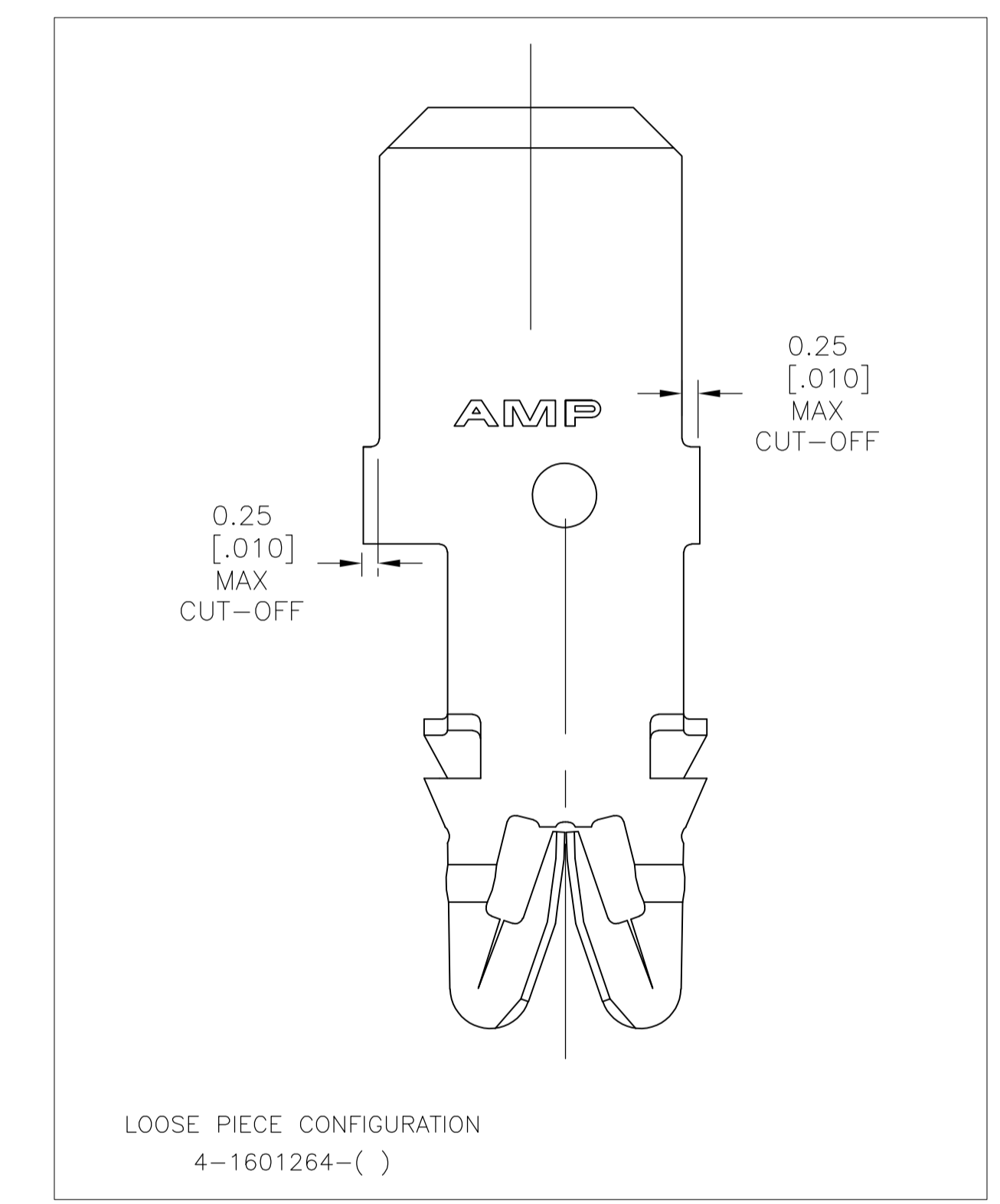
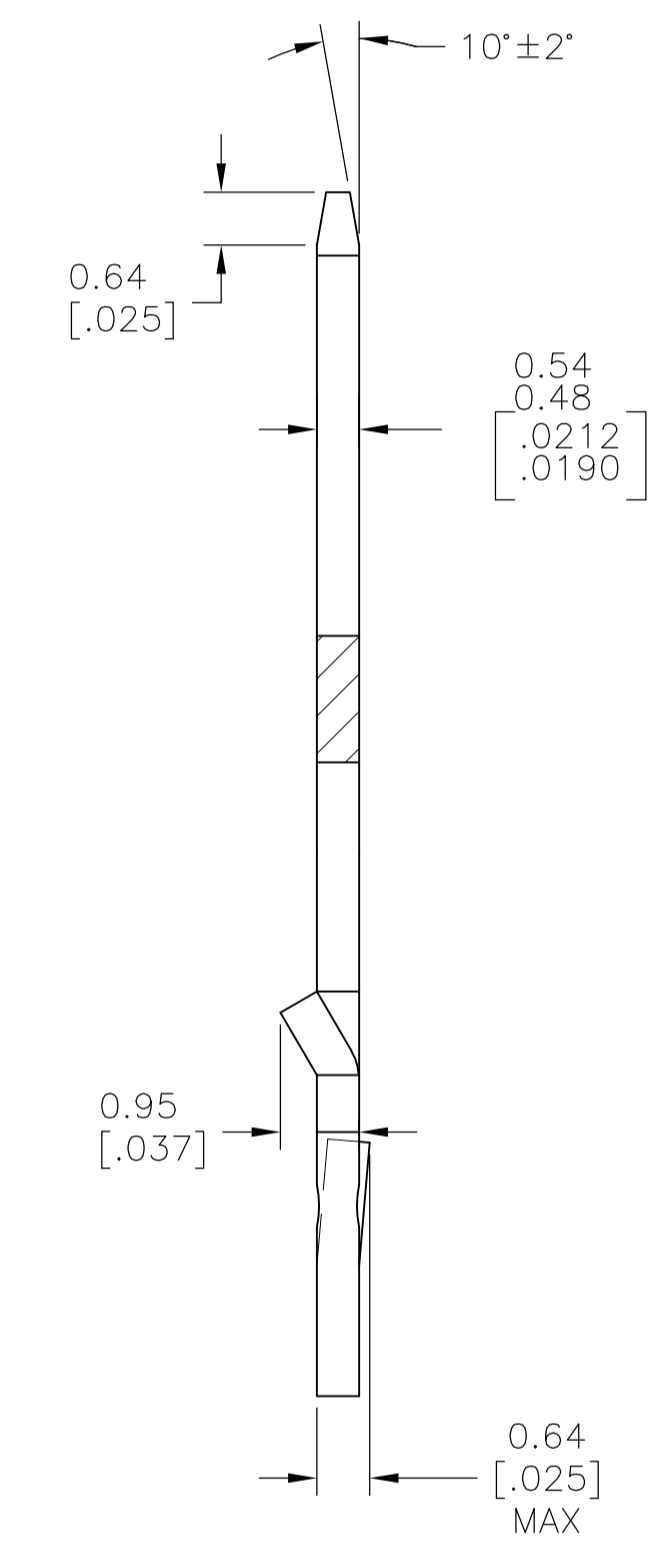
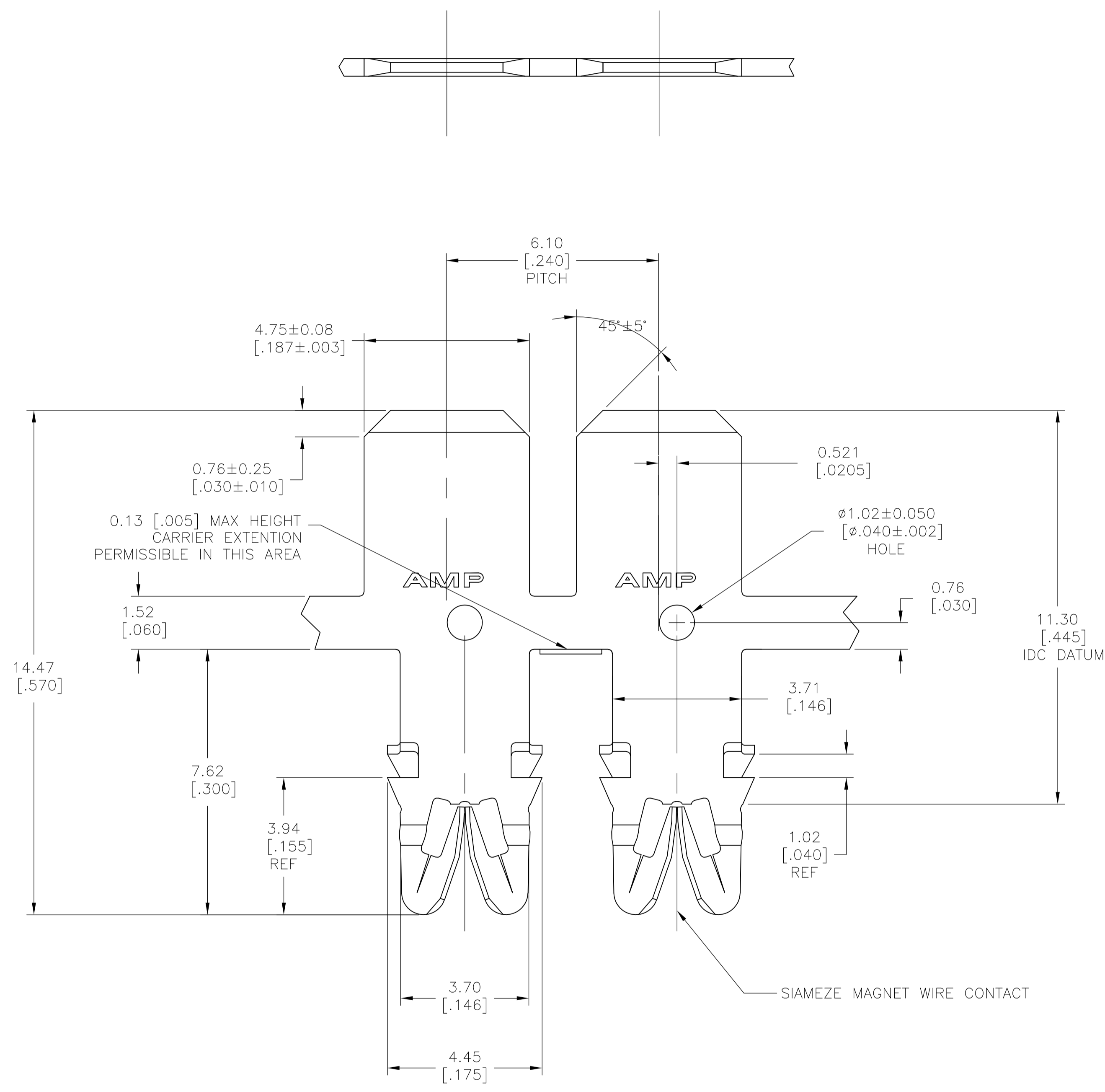

| | | |
|-----------|---|-------------|
| 8 | 9 | 4-1601264-2 |
| 7 | | 1601264-4 |
| 6 | 9 | 1601264-3 |
| STANDARD | 9 | 1601264-2 |
| PACKAGING | | PART NUMBER |

| | | | | | | | |
|----------------------------------------|--|----------------------------------------|--|---------------------|--|---------------------|--|
| THIS DRAWING IS A CONTROLLED DOCUMENT. | | DIN JR_RUTH 10MAR11 | | GK G_JACONO 10MAR11 | | NAME | |
| DIMENSIONS: mm [INCHES] | | TOLERANCES UNLESS OTHERWISE SPECIFIED: | | PRODUCT SPEC | | APPLICATION SPEC | |
| 0 PLC ± - | | 1 PLC ± - | | 2 PLC ± 0.13 [.005] | | 3 | |
| 3 PLC ± - | | 4 PLC ± - | | ANGLES ± ° | | SIZE | |
| MATERIAL FULL HARD BRASS | | FINISH 4 | | WEIGHT | | A1 00779 1601264 | |
| | | CUSTOMER DRAWING | | SCALE 11:1 | | SHEET 1 OF 1 REV A1 | |