



Chipsmall Limited consists of a professional team with an average of over 10 year of expertise in the distribution of electronic components. Based in Hongkong, we have already established firm and mutual-benefit business relationships with customers from,Europe,America and south Asia,supplying obsolete and hard-to-find components to meet their specific needs.

With the principle of “Quality Parts,Customers Priority,Honest Operation,and Considerate Service”,our business mainly focus on the distribution of electronic components. Line cards we deal with include Microchip,ALPS,ROHM,Xilinx,Pulse,ON,Everlight and Freescale. Main products comprise IC,Modules,Potentiometer,IC Socket,Relay,Connector.Our parts cover such applications as commercial,industrial, and automotives areas.

We are looking forward to setting up business relationship with you and hope to provide you with the best service and solution. Let us make a better world for our industry!



## Contact us

Tel: +86-755-8981 8866 Fax: +86-755-8427 6832

Email & Skype: info@chipsmall.com Web: www.chipsmall.com

Address: A1208, Overseas Decoration Building, #122 Zhenhua RD., Futian, Shenzhen, China



THIS DRAWING IS UNPUBLISHED. RELEASED FOR PUBLICATION  
 © COPYRIGHT BY TYCO ELECTRONICS CORPORATION. ALL RIGHTS RESERVED.

LOC	DIST	REVISIONS			
P	LTR	DESCRIPTION	DATE	DWN	APVD
AF	50	A2	REVISED PER ECR-08-005025	03MAR08	DML DML

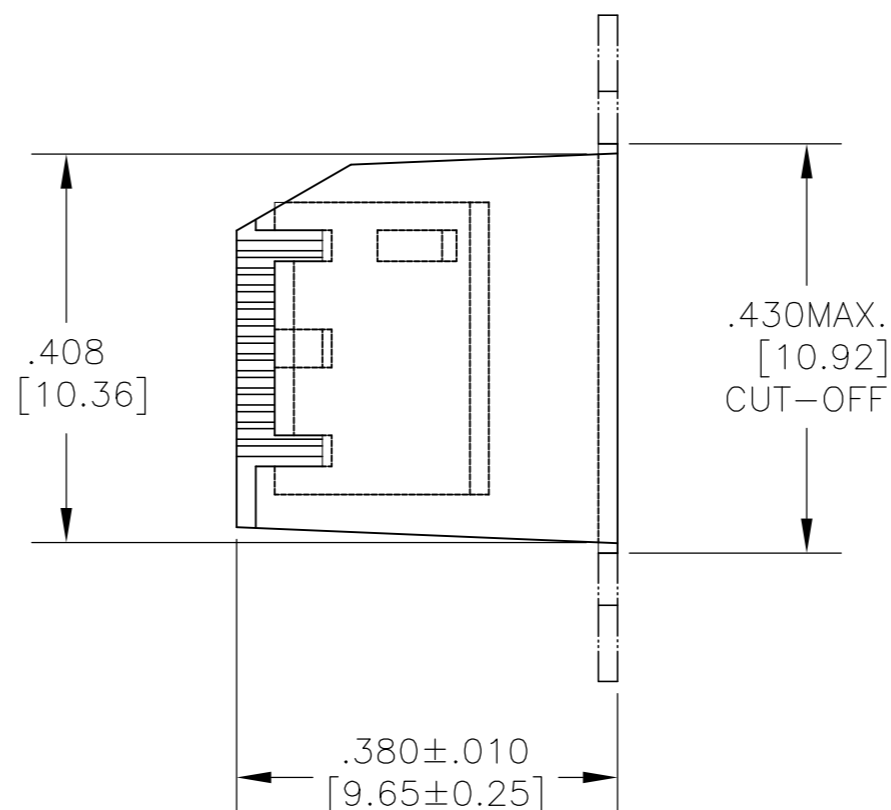
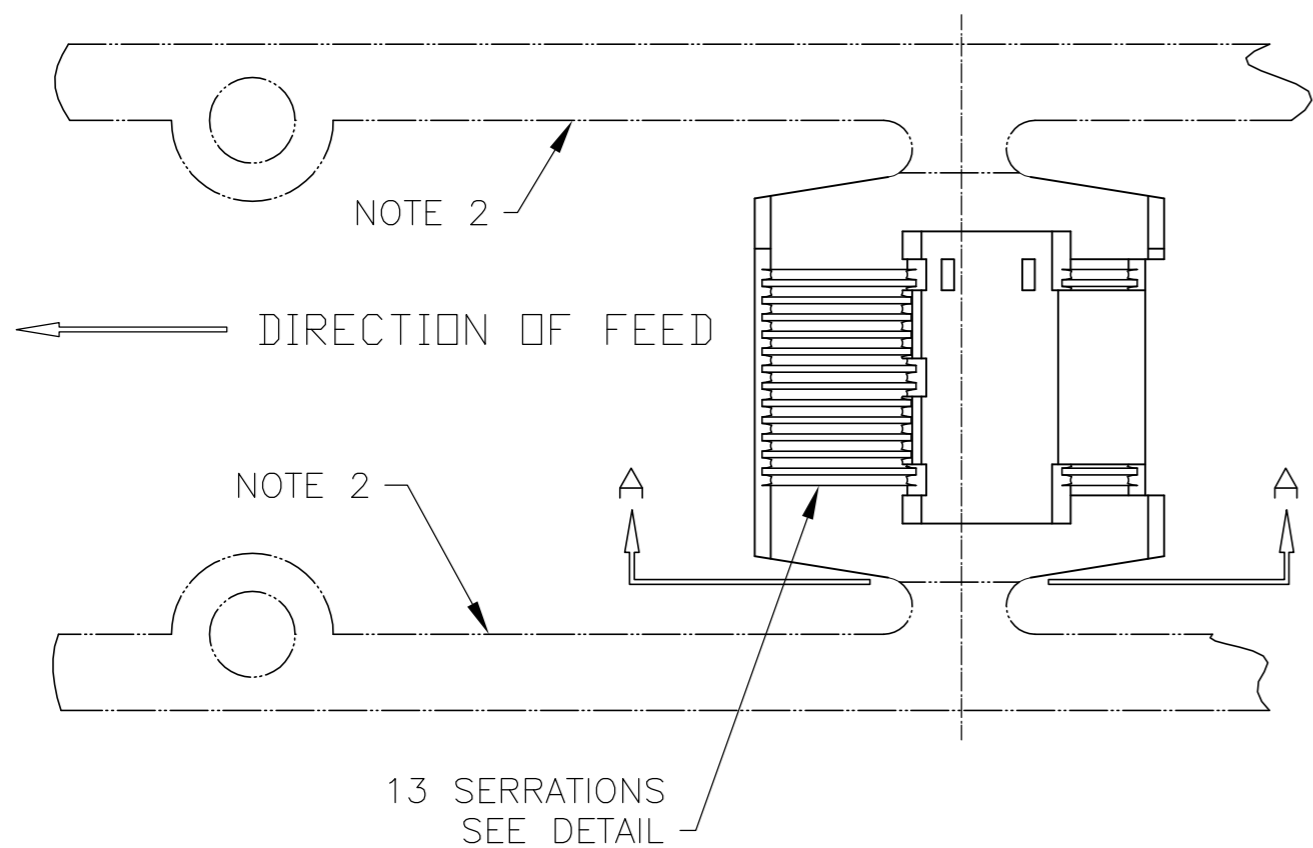

- SPECIFICATIONS  
 LEAD WIRE : #14-#10 AWG (2.0-5.6mm<sup>2</sup>) (4,000-11,000 CMA)  
 2 WIRES MAX  
 MAGNET WIRE: #20-#11 AWG (0.81-2.30mm<sup>2</sup>) (1,000-9,000 CMA)  
 8 WIRES MAX  
 TOTAL WIRE: 4,000-40,000 CMA  
 CRIMP HEIGHT: (TOTAL CMA + 39,000) / 516,000

2. CARRIER STRIPS (PHANTOM LINES) TO SCRAP DURING INSERTION.

3 FINISH: PRE-TIN PLATE OVER COPPER UNDERPLATE.

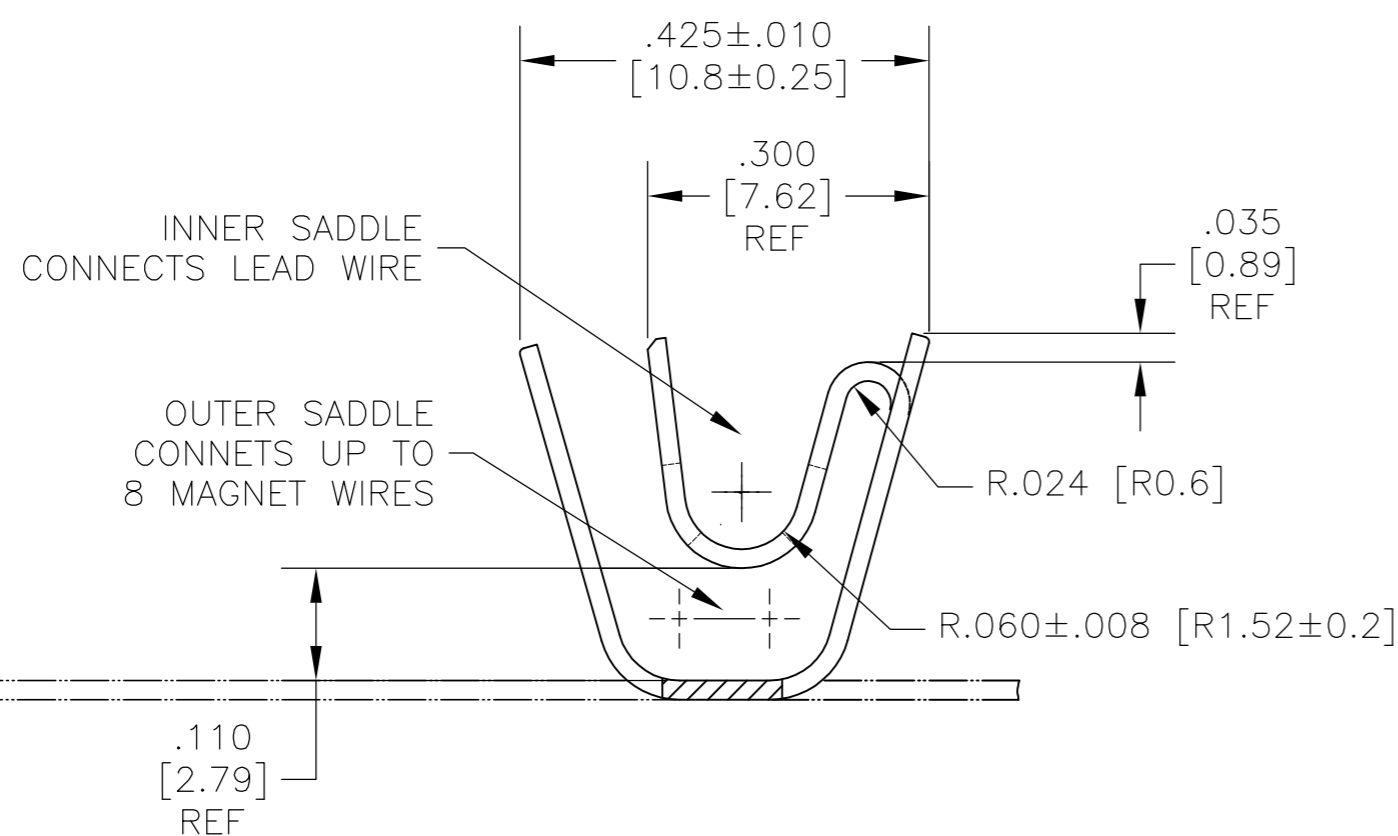

SERRATION DETAIL  
SCALE 40X

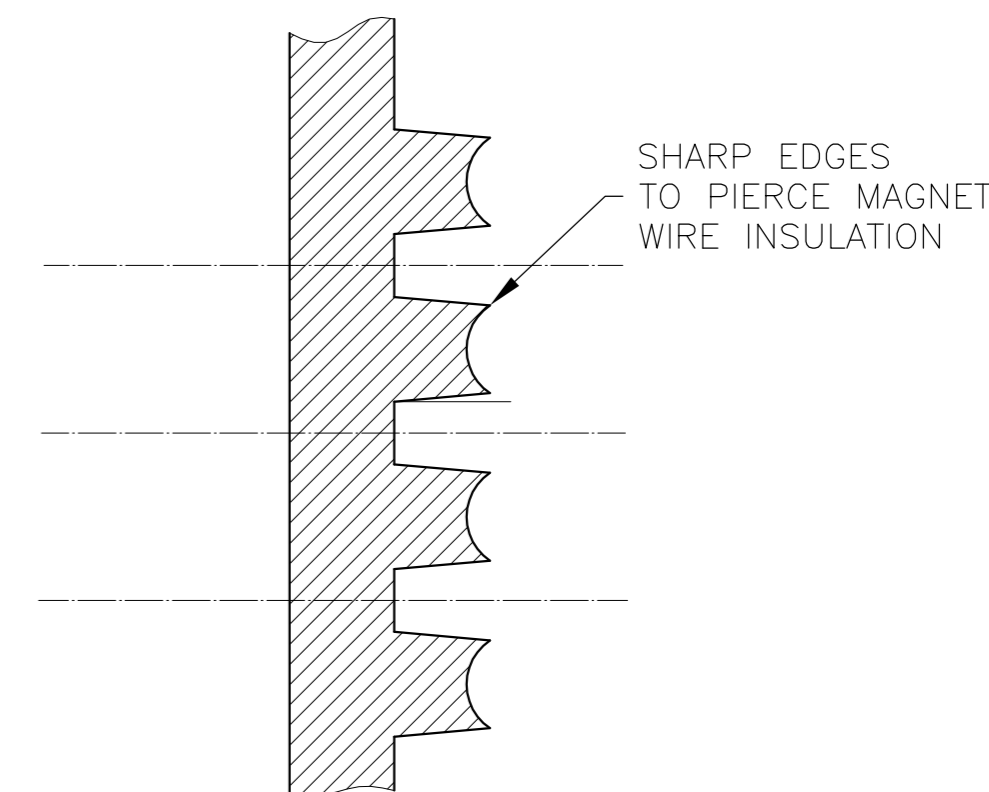

TERMINALS TO UNWIND FROM REELS AS SHOWN:

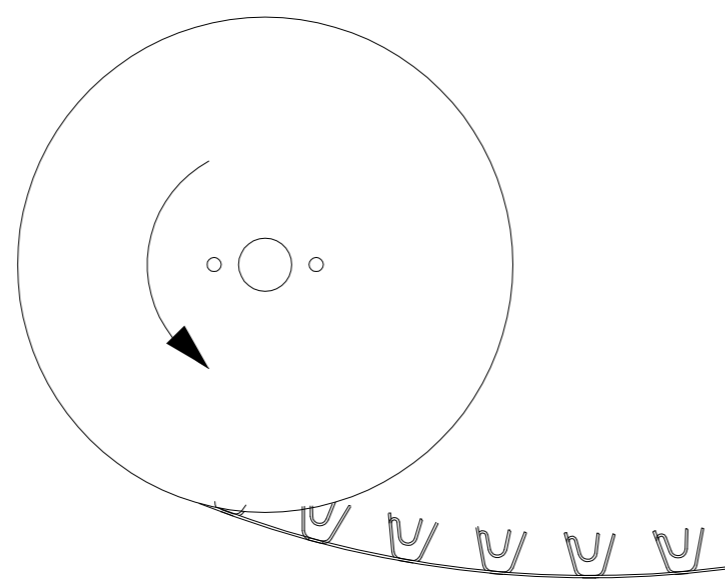

-		-		-	
3		111-000-001		1601953-1	
FINISH		REFERENCE PART NUMBER		TYCO PART NUMBER	
THIS DRAWING IS A CONTROLLED DOCUMENT.		DWN 18JUL2002		Tyco Electronics Corporation Harrisburg, PA 17105-3608	
DIMENSIONS: INCHES		CHK G JACONO 18JUL2002		NAME	
TOLERANCES UNLESS OTHERWISE SPECIFIED:		APVD G JACONO 18JUL2002		PRODUCT SPEC	
0 PLC ± -		APPLICATION SPEC		SIZE CAGE CODE DRAWING NO	
1 PLC ± -		114-13093		RESTRICTED TO	
2 PLC ± .01[0.13]		WEIGHT -		A2 00779 C=1601953	
3 PLC ± .005[0.026]		CUSTOMER DRAWING		SCALE 1:1 SHEET 1 of 1 REV A2	
4 PLC ± -					
ANGLES ± 3°					
FINISH					
BRASS, HALF HARD					