



Chipsmall Limited consists of a professional team with an average of over 10 year of expertise in the distribution of electronic components. Based in Hongkong, we have already established firm and mutual-benefit business relationships with customers from,Europe,America and south Asia,supplying obsolete and hard-to-find components to meet their specific needs.

With the principle of “Quality Parts,Customers Priority,Honest Operation,and Considerate Service”,our business mainly focus on the distribution of electronic components. Line cards we deal with include Microchip,ALPS,ROHM,Xilinx,Pulse,ON,Everlight and Freescale. Main products comprise IC,Modules,Potentiometer,IC Socket,Relay,Connector.Our parts cover such applications as commercial,industrial, and automotives areas.

We are looking forward to setting up business relationship with you and hope to provide you with the best service and solution. Let us make a better world for our industry!



Contact us

Tel: +86-755-8981 8866 Fax: +86-755-8427 6832

Email & Skype: info@chipsmall.com Web: www.chipsmall.com

Address: A1208, Overseas Decoration Building, #122 Zhenhua RD., Futian, Shenzhen, China



Torque Sensors

Honeywell



SENSING AND CONTROL

Product Range Guide

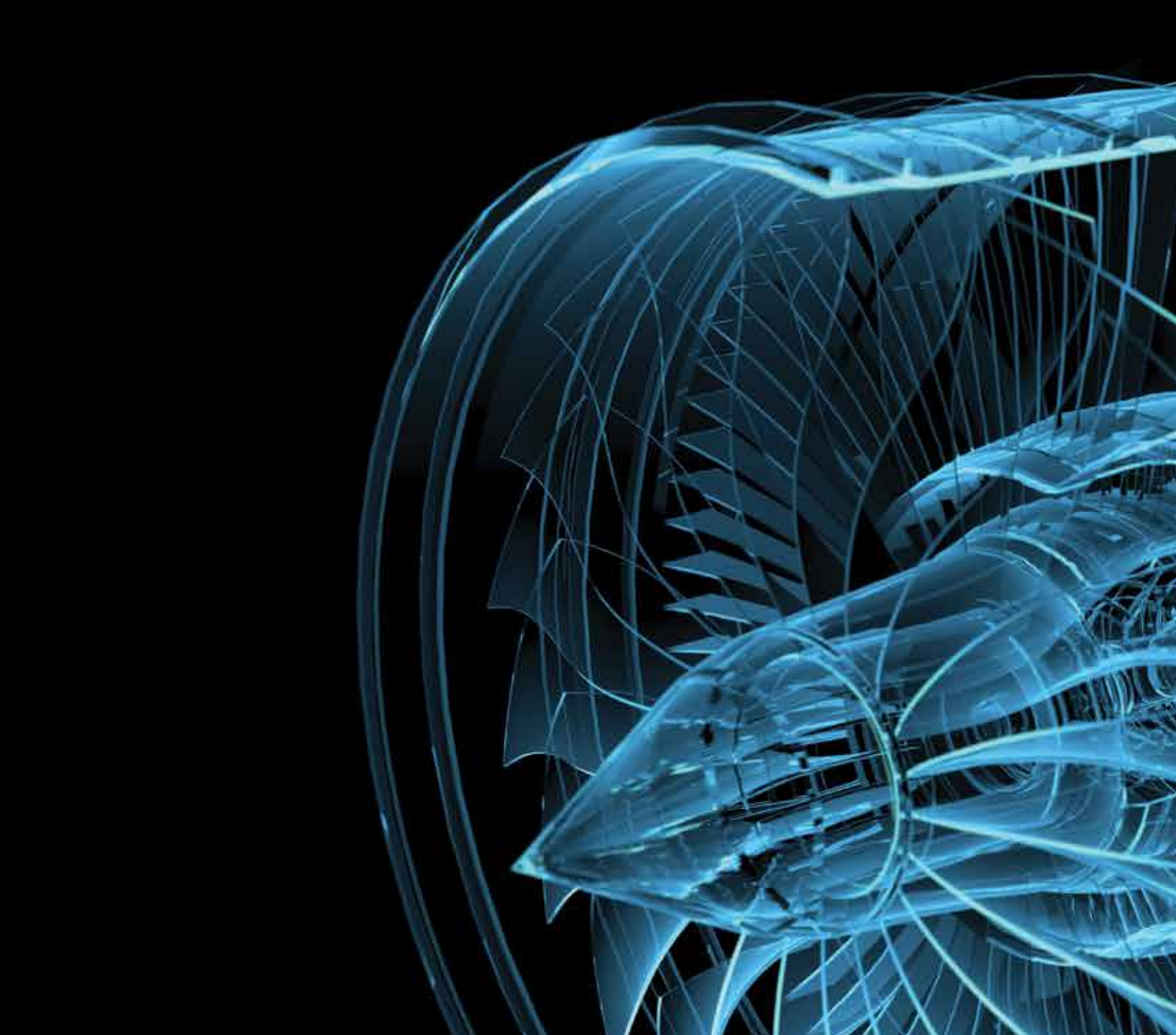
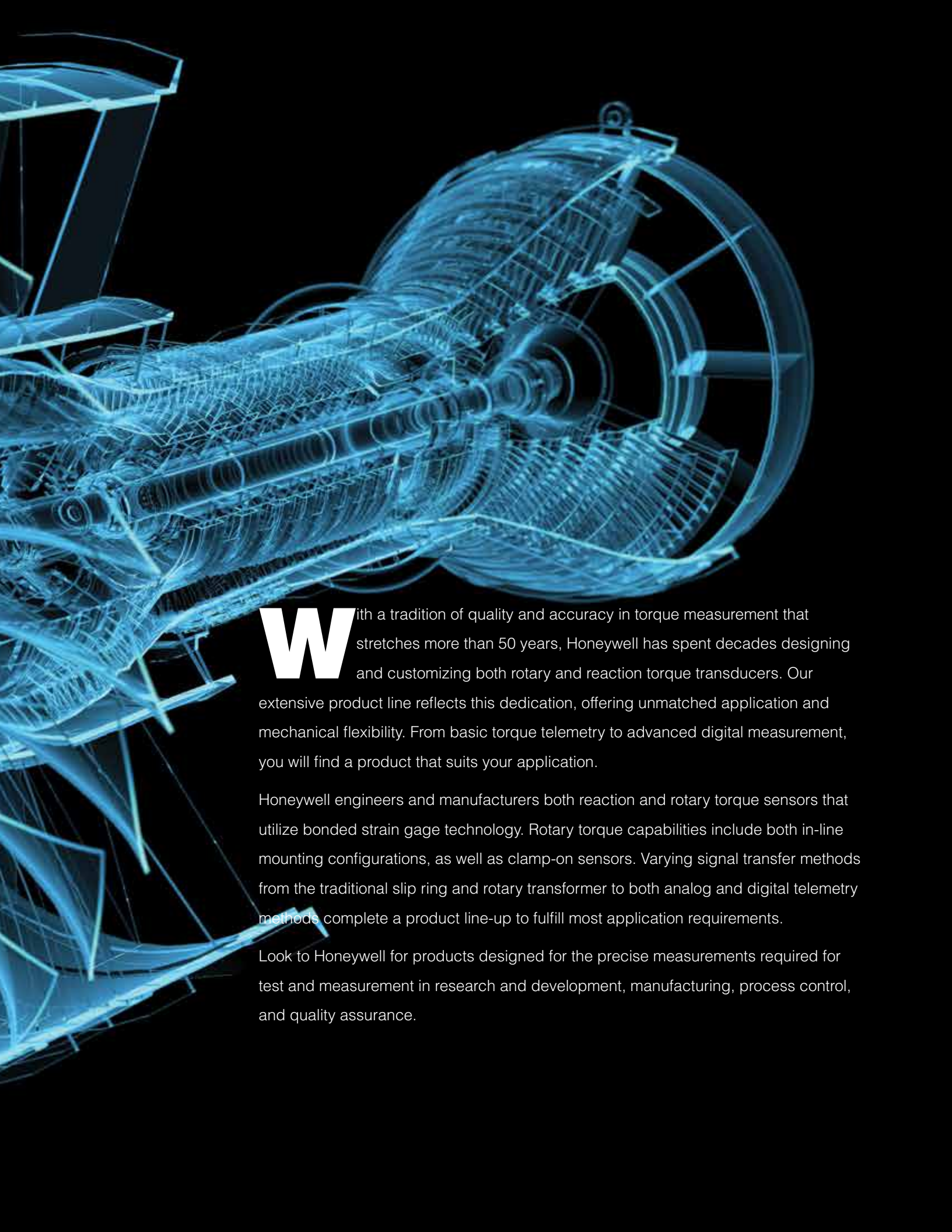

Table of Contents

Introduction	2-3
Digital Telemetry	4-5
Torque Transducers (Rotary)	6-7
Torque Transducers (Slip Ring/Shaft)	8
Torque Transducers (Slip Ring/Square Drive)	9
Torque Transducers (Slip Ring/Special Apps)	10-11
Torque Transducers (Rotary, Non-Contact)	12
Wireless Telemetry (Rotary Measurement)	13
Wireless Telemetry (Clamp-on Measurement)	14-15
Torque Transducers (Reaction - Flanged)	16
Torque Transducers (Reaction - Special Configs)	17
Torque Transducers (Reaction - Miniature)	18
Torque Transducers (Reaction - Shaft)	19
Torque Transducers (Reaction - Square Drive)	20
Torque Transducers (Reaction - Torque/Thrust)	21
Torque Transducers (Reaction - Torque Watch)	22
Accessories	23



With a tradition of quality and accuracy in torque measurement that stretches more than 50 years, Honeywell has spent decades designing and customizing both rotary and reaction torque transducers. Our extensive product line reflects this dedication, offering unmatched application and mechanical flexibility. From basic torque telemetry to advanced digital measurement, you will find a product that suits your application.

Honeywell engineers and manufacturers both reaction and rotary torque sensors that utilize bonded strain gage technology. Rotary torque capabilities include both in-line mounting configurations, as well as clamp-on sensors. Varying signal transfer methods from the traditional slip ring and rotary transformer to both analog and digital telemetry methods complete a product line-up to fulfill most application requirements.

Look to Honeywell for products designed for the precise measurements required for test and measurement in research and development, manufacturing, process control, and quality assurance.

Digital Telemetry

TMS 9250



Honeywell's TMS 9250 digital telemetry torque measurement system offers a wireless, non-contact method to measure torque on rotating parts. The wireless design enables higher integrity of the torque data captured through higher resolution, higher sensitivity, faster response, and no mechanical interferences. The result is a more accurate indication of the actual torque being experienced, plus an increase in overall system reliability.

Fully software driven, the TMS 9250 features quick and easy setup, and selectable outputs which can be easily adjusted as needed. With no slip rings or bearings to replace, less routine maintenance is required. The flexible, compact modular design also allows the system to be easily adapted or customized to fit into many types of torque test and measurement applications such as those found in automotive / transportation, aerospace, and industrial manufacturing.



Series	DIN Series	SAE Series
Description	wireless telemetry	
Range	100 Nm to 10K Nm [50 lb-ft to 8K lb-ft]*	
Accuracy	±0.05 % rated output (±0.1 % for ranges larger than 10K Nm [8K ft-lb])	
Non-linearity	±0.05 % rated output (±0.1 % for ranges larger than 10K Nm [8K ft-lb])	
Hysteresis	±0.05 % rated output (±0.1 % for ranges larger than 10K Nm [8K ft-lb])	
Output	±10 V; 4-20 mA; 10 KHz ±5 KHz; 60 KHz ±20 KHz	
Temperature, operating	Sensor and CCM: -40 °C to 85 °C [-40 °F to 185 °F] SPM and Power Supply: 0 °C to 40 °C [32 °F to 104 °F]	
Temperature, compensated	Sensor and CCM: -10 °C to 50 °C [14 °F to 122 °F]	
RPM rating	up to 20000 rpm	

* consult factory for capacity above 10K Nm

Features

- 0.05 % full scale, total system accuracy
- DIN, SAE, shaft to shaft, integral or custom couplings available
- High torsional stiffness with low rotating inertia
- Multiple, field selectable analog outputs, scalable “on the fly”
- Compact, modular design to fit into tight spaces
- Quick and easy installation with full software set-up
- FCC and CE certified, meeting all EMC emission and susceptibility requirements

For more information, specifications, or to place an order, please visit us online at <http://measurementsensors.honeywell.com> or contact us at 800-848-6564 or +1 614-850-5000.



Shaft	Integral Coupling	Special
wireless telemetry	wireless telemetry	wireless telemetry
0.35 Nm [50 oz-in] to 7 Nm [1K oz-in] 5 Nm [50 in-lbs] and up	300 Nm [250 lb-ft] and up	50 Nm [50 lb-ft] and up
±0.05 % rated output	±0.05 % rated output	±0.05 % rated output
±0.05 % rated output	±0.05 % rated output	±0.05 % rated output
±0.05 % rated output	±0.05 % rated output	±0.05 % rated output
±10 V; 4-20 mA; 10 KHz ±5 KHz; 60 KHz ±20 KHz	±10 V; 4-20 mA; 10 KHz ±5 KHz; 60 KHz ±20 KHz	±10 V; 4-20 mA; 10 KHz ±5 KHz; 60 KHz ±20 KHz
Sensor and CCM: -40 °C to 85 °C [-40 °F to 185 °F] SPM and Power Supply: 0 °C to 40 °C [32 °F to 104 °F]	Sensor and CCM: -40 °C to 85 °C [-40 °F to 185 °F] SPM and Power Supply: 0 °C to 40 °C [32 °F to 104 °F]	Sensor and CCM: -40 °C to 85 °C [-40 °F to 185 °F] SPM and Power Supply: 0 °C to 40 °C [32 °F to 104 °F]
Sensor and CCM: -10 °C to 50 °C [14 °F to 122 °F]	Sensor and CCM: -10 °C to 50 °C [14 °F to 122 °F]	Sensor and CCM: -10 °C to 50 °C [14 °F to 122 °F]
up to 20000 rpm	up to 20000 rpm	–

Typical Applications

- Powertrain testing: engine, engine diagnostics, cold engine, transmission driveshaft and rear axle differential
- Dynamometer
- Brakes and wheel hub
- Drive wheels
- Continuous track, heavy equipment
- Oil and water pump testing
- Jet engine / turbine testing
- Wind power gearbox and torsion blade testing / propeller testing
- Turn up / turn down gear box testing
- Industrial motor / generator testing
- Auxiliary component efficiency testing

Torque Transducers

Rotary • Non-Contact, Unamplified, Shaft



Honeywell offers non-contact, rotary transformer, shaft torque sensors for installations running long-term durability testing. The non-contact nature of the signal transfer virtually eliminates the need for maintenance. High overload protection with high signal output helps prevent potential damage to the sensor. The carrier frequency excitation provides increased signal/noise immunity. Models offered include low capacity (50 in-oz [0,35 Nm] to 1,000 in-oz [7 Nm]) and standard (50 in-lb [5 Nm] to 100,000 in-lb [11300 Nm]) capacity ranges, both with 0.1 % non-linearity and hysteresis. Models with enhanced accuracy (up to 0.05 % non-linearity and hysteresis) are also available.



Series	1602	1604-1607	1800 Series
Description	shaft	shaft	shaft
ac carrier excitation requirement	Excitation voltage, 10 Vac max. rms: 3.28 kHz optimum	Excitation voltage, 10 Vac max. rms: 3.28 kHz optimum	Excitation voltage, 10 Vac max. rms: 3.28 kHz optimum
Range	0,35 Nm to 7,06 Nm [50 oz-in to 1,000 oz-in]	5,6 Nm to 11298,5 Nm [50 lb-in to 100,000 lb-in]	11,3 Nm to 11298,5 Nm [100 lb-in to 100,000 lb-in]
Accuracy	0.15 % rated output	0.15 % rated output	0.07 % rated output
Non-linearity	±0.1 % rated output	±0.1 % rated output	±0.05 % rated output
Hysteresis	±0.1 % rated output	±0.1 % rated output	±0.05 % rated output
Output	±2 mV/V (nominal)	±2 mV/V (nominal)	±2 mV/V (nominal)
Temperature, operating	-29 °C to 93 °C [-20 °F to 200 °F]	-29 °C to 93 °C [-20 °F to 200 °F]	-29 °C to 93 °C [-20 °F to 200 °F]
Temperature, compensated	21 °C to 77 °C [70 °F to 170 °F]	21 °C to 77 °C [70 °F to 170 °F]	21 °C to 77 °C [70 °F to 170 °F]
Electrical termination	MS-3102E-14S-5P	MS-3102E-14S-5P	MS-3102E-14S-5P
RPM rating	20,000	<ul style="list-style-type: none"> • 50 lb-in to 2,000 lb-in = 10,000 • 2,000 lb-in, 5,000 lb-in, 10,000 lb-in = 10,000 • 20,000 lb-in, 30,000 lb-in = 6,700 • 50,000 lb-in, 100,000 lb-in = 6,000 	<ul style="list-style-type: none"> • 100 lb-in to 2,000 lb-in = 27,000 • 2,000 lb-in, 5,000 lb-in, 10,000 lb-in = 22,000 • 20,000 lb-in = 12,000 • 50,000 lb-in, 100,000 lb-in = 10,000

Features

- 0.1 % non-linearity and hysteresis; 0.05 % for enhanced accuracy models
- Speed sensor and foot mount options available
- High overload protection with high signal output (sensitivity)
- Extended speed range
- Minimal maintenance due to bearings only contact
- Carrier frequency excitation provides increased signal/noise immunity

Typical Applications

- Motor testing and development
- Quality assurance testing
- Automated assembly process monitoring
- Gear boxes, pump, and drive line testing
- Torque test stands (startup, running, and stall torque level monitoring)
- Conveyers / belt drive monitoring
- Mixing and/or viscosity control

see page 23 for additional models available.

Torque Transducers

Rotary • Non-Contact, Unamplified, Special



Honeywell offers a range of non-contact rotary torque sensors adaptable for many special applications, including hydraulic pump testing, hydraulic motor testing, military aircraft test stands, aircraft starter testing, and cross-bleed starting.



Series	1815A, 1815K	1388-124
Description	special application	special application
ac carrier excitation requirement	Excitation voltage, 10 Vac max. rms: 3.28 kHz optimum	Excitation voltage, 10 Vac max. rms: 3.28 kHz optimum
Range	5,65 Nm to 112,98 Nm [50 lb-in to 1,000 lb-in] ("A" spline) 5,65 Nm to 1129,84 Nm [50 lb-in to 10,000 lb-in] ("K" spline)	56,5 Nm [500 lb-in] 112,98 Nm [1,000 lb-in]
Accuracy	0.07 % rated output	0.21 % rated output
Non-linearity	±0.05 % rated output	±0.1 % rated output
Hysteresis	±0.05 % rated output	±0.1 % rated output
Output	±2 mV/V (nominal)	2 mV/V (nominal)
Temperature, operating	-29 °C to 93 °C [-20 °F to 200 °F]	-29 °C to 93 °C [-20 °F to 200 °F]
Temperature, compensated	21 °C to 77 °C [70 °F to 170 °F]	22 °C to 77 °C [70 °F to 170 °F]
Electrical termination	MS-3102E-14S-5P	MS-3102E-14S-5P speed rating
RPM rating	25,000; 15,000	5,000

Features

- 0.05 % & 0.1 % non-linearity and hysteresis
- 1815: minimal maintenance due to "bearings only" contact
- 1388-124: Reduced sensitivity to belt/chain tension loads on torque readings not to exceed maximum overhung moment

Typical Applications

- Feedback control loop on textile machinery
- Processing torque
- Belt-driven pulley torque monitoring
- Chain-driven sprocket torque monitoring
- Spindle control
- Roll or web-tension monitoring

For more information, specifications, or to place an order, please visit us online at <http://measurementsensors.honeywell.com> or contact us at 800-848-6564 or +1 614-850-5000.

Torque Transducers

Slip Ring • Shaft

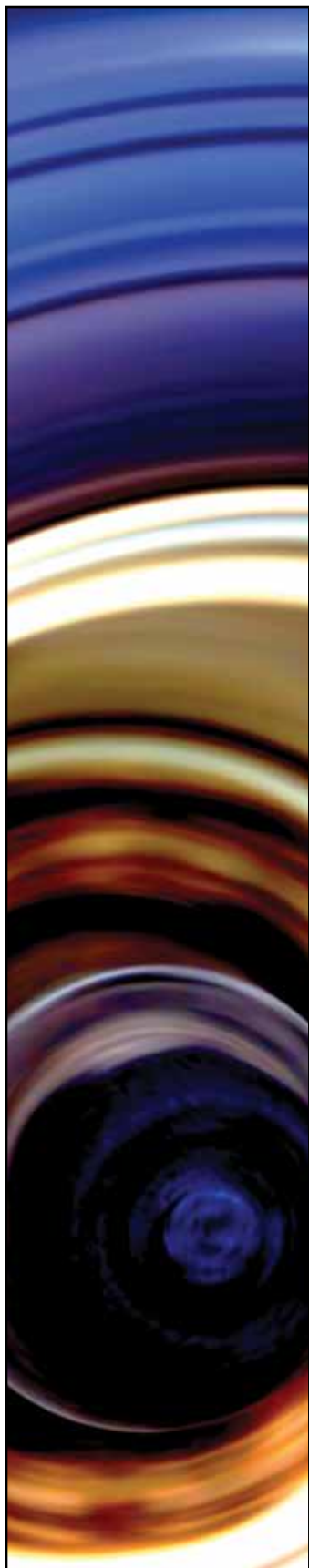

Honeywell's shaft, slip ring torque sensors are designed for fractional horsepower motor test applications and to monitor start up, running and stall torque levels. These rugged torque sensors are offered in capacities from 10 oz-in (0,07 Nm) up to 100000 in-lb (11300 Nm) for shaft-mounting configurations.



Series	1103	1102	1100 Series
Description	shaft	shaft	shaft
Range	0,07 Nm [10 oz-in], 0,14 Nm [20 oz-in]	0,35 Nm to 7,06 Nm [50 oz-in to 1,000 oz-in]	11,3 Nm to 11298,5 Nm [100 lb-in to 100,000 lb-in]
Accuracy	0.09 % rated output	0.15 % rated output	0.15 % rated output
Non-linearity	±0.05 % rated output	±0.1 % rated output	±0.1 % rated output
Hysteresis	±0.05 % rated output	±0.1 % rated output	±0.1 % rated output
Output	±0.95 mV/V (nominal)	±2 mV/V (nominal)	±2 mV/V (nominal)
Temperature, operating	-29 °C to 93 °C [-20 °F to 200 °F]	-29 °C to 93 °C [-20 °F to 200 °F]	-29 °C to 93 °C [-20 °F to 200 °F]
Temperature, compensated	21 °C to 77 °C [70 °F to 170 °F]	21 °C to 77 °C [70 °F to 170 °F]	21 °C to 77 °C [70 °F to 170 °F]
Electrical termination	PT02E-10-6P	PT02E-10-6P	MS-3102E-14S-5P
RPM rating	20,000	20,000	100 lb-in to 2,000 lb-in = 9,000 5,000 lb-in , 10,000 lb-in = 8,500 20,000 lb-in = 4,500 50,000 lb-in, 100,000 lb-in = 4,000

Features

- Capacity ranges from 10 oz-in (0,07 Nm) up to 100,000 in-lb [11300 Nm]
- 0.05 % or 0.1 % non-linearity and hysteresis
- Higher frequency response
- Can be used with almost all existing dc and ac signal conditioning equipment
- Cost-effective option for general in-line applications

Typical Applications

- Motor testing and development
- Quality assurance testing
- Small pump testing
- Drive-line or gear box torque monitoring
- Conveyors / belt drive monitoring
- Paper mill drive motor monitoring
- Torque test stands
- Medical device monitoring

see page 23 for additional models available.

For more information, specifications, or to place an order, please visit us online at <http://measurementsensors.honeywell.com> or contact us at 800-848-6564 or +1 614-850-5000.

Torque Transducers

Slip Ring • Square Drive



Honeywell's square drive, slip ring torque sensors measure the output torque of stall and clutch-type nut-runners in production fastening operations. Units equipped with incremental encoders are available for applications where the fastener's angle of rotation as well as torque data are required. These sensors are often used to monitor operation of systems using the following fastening strategies: turn of the nut, tension control and yield control.



Series	1254
Description	square drive
Range	5,6 Nm to 1355,8 Nm [50 lb-in to 1,000 lb-ft]
Accuracy	0.23 % rated output
Non-linearity	±0.15 % rated output
Hysteresis	±0.15 % rated output
Output	±2 mV/V ±0.25 % full scale
Temperature, operating	-29 °C to 93 °C [-20 °F to 200 °F]
Temperature, compensated	21 °C to 77 °C [70 °F to 170 °F]
Electrical termination	PT02H-12-10P
RPM rating	5000

Features

- Capacity ranges from 50 in-lb to 1000 ft-lb
- 0.15 % non-linearity and hysteresis
- Hex (in-lb sizes) and square drive configurations
- Incremental encoder option
- Adaptable for portable usage
- No special adapter tools required
- Repeatable torque measurements

Typical Applications

- Calibration reference for "hard usage" mechanical torque wrenches
- Fastening torque monitoring
- Torque to turn
- Nut running
- Tension and/or yield control

For more information, specifications, or to place an order, please visit us online at <http://measurementsensors.honeywell.com> or contact us at 800-848-6564 or +1 614-850-5000.

Torque Transducers

Slip Ring • Special Application



Honeywell offers a range of slip ring torque sensors adaptable for many special industrial applications, including measuring steering torque feedback for automobiles, trucks, buses, and material handling equipment, wheel cornering testing, and precision feedback control on textile machinery.



Series	1246	1388-102
Description	special application	special application
Range	2259,7 Nm to 22597 Nm [20K lb-in to 200K lb-in]	56,5 Nm [500 lb-in] 112,98 Nm [1,000 lb-in]
Accuracy	0.37 % rated output	0.21 % rated output
Non-linearity	±0.25 % rated output	±0.1 % rated output
Hysteresis	±0.25 % rated output	±0.1 % rated output
Output	±1.5 mV/V (nominal)	±2 mV/V (nominal)
Temperature, operating	-29 °C to 93 °C [-20 °F to 200 °F]	-29 °C to 93 °C [-20 °F to 200 °F]
Temperature, compensated	21 °C to 77 °C [70 °F to 170 °F]	21 °C to 77 °C [70 °F to 170 °F]
Electrical termination	PT02H-10-6P	PT02H-10-6P
RPM rating	5,000	5,000

Features

- Slip ring torque sensors for special applications
- Large selection of capacities and sizes
- Custom options available

Typical Applications

- Automotive brake testing
- Automotive wheel torque design
- Car, truck or bus steering effort measurement
- Marine steering effort measurement
- Belt-driven pulley, chain-driven sprocket monitoring
- Spindle control
- Roll or web-tension monitoring
- Feedback control loop

For more information, specifications, or to place an order, please visit us online at <http://measurementsensors.honeywell.com> or contact us at 800-848-6564 or +1 614-850-5000.



1369

special application

67,8 Nm [50 lb-ft],
135,6 Nm [100 lb-ft], 271,1 Nm [200 lb-ft]

0.79 % rated output

< 0.50 % rated output

< 0.50 % rated output

±2 mV/V (nominal)

-29 °C to 93 °C [-20 °F to 200 °F]

21 °C to 77 °C [70 °F to 170 °F]

PT02E-12-8P

100

1115A, 1115K

special application

56,5 Nm to 112,98 Nm [50 lb-in to 1,000 lb-in]
("A" spline),
56,5 Nm to 1129,85 Nm [50 lb-in to 10,000 lb-in]
("K" spline)

0.15 % rated output

±0.1 % rated output

±0.1 % rated output

±2 mV/V (nominal)

-29 °C to 93 °C [-20 °F to 200 °F]

21 °C to 77 °C [70 °F to 170 °F]

MS-3102E-14S-5P

–

1242, 1239 and 1308

special application

3389,5 Nm to 6779,1 Nm [30,000 lb-in to 60,000 lb-in] (1242),
564,9 Nm to 2259,7 Nm [5,000 lb-in to 20,000 lb-in] (1239),
1129,8 Nm to 2259,7 Nm [10,000 lb-in to 20,000 lb-in] (1308)

0.36 % rated output

±0.25 % rated output

±0.25 % rated output

±1 mV/V (nominal) , ±1.5 mV/V (nominal)

-29 °C to 93 °C [-20 °F to 200 °F]

21 °C to 77 °C [70 °F to 170 °F]

MS-3102E-14S-5P

–

Torque Transducers

Rotary • Non-Contact, Amplified, Shaft/Square

With their compact size and multiple mounting options, Honeywell's non-contact amplified rotary torque sensors are suitable for laboratory applications as well as industrial environments, and are offered in either shaft or square drive styles. The contactless transmission of supply voltage and measuring signal enables continuous operation with low maintenance.



Series	1700 Series	1754
Description	shaft	square drive
Range	0,02 Nm to 1500 Nm [0.18 lb-in to 13276.1 lb-in]	500 Nm to 2,000 Nm [4425.3 lb-in to 17701.5 lb-in]
Accuracy	< 0.25 % rated output	< 0.25 % rated output
Non-linearity	±0.1 % rated output	±0.15 % rated output
Hysteresis	±0.1 % rated output	±0.1 % rated output
Output	±10 volts	±5 volts
Temperature, operating	0 °C to 60 °C [32 °F to 140 °F]	0 °C to 60 °C [32 °F to 140 °F]
Temperature, compensated	5 °C to 45 °C [41 °F to 113 °F]	5 °C to 45 °C [41 °F to 113 °F]
Electrical termination	12-pin binder	12-pin binder
RPM rating	up to 37,000	12,000

Features

- Non-contact amplified rotary torque sensor
- 0,02 Nm to 1500 Nm capacity range or 500 Nm to 2000 Nm capacity range
- 0.25 % accuracy
- Built-in instrumentation amplifier (high level voltage output)
- Speed sensor or angle encoder option
- Compact size
- Custom options available

Typical Applications

- Motor and transmission testing
- Gear boxes, pump, and drive line testing
- Automated assembly process monitoring
- Conveyors/belt drive monitoring
- Paper mill drive motor monitoring
- Torque test stands
- Mixing and/or viscosity control

For more information, specifications, or to place an order, please visit us online at <http://measurementsensors.honeywell.com> or contact us at 800-848-6564 or +1 614-850-5000.

Wireless Telemetry Rotary Measurement Systems



Where other measurement methods are affected by vibration, dust, moisture, high RPMs, and large axial/radial shaft movements, Honeywell's Model 2100 series (2101 - 2106) and 1202B series wireless telemetry rotary torque measurement systems are designed for both short and long term testing and monitoring of torque or strain on these rotating applications. A combination of up to six transmitters and receivers operating on different frequencies provide up to six points of measurement on the same shaft. A scaleable analog output and numeric display readout on the receiver provides electrical and visual indication of the measurement.

These products are highly customizable to meet individual measurement and monitoring needs; contact Honeywell to discuss your particular application and environment.



Series	2101-2106 Rotary Measurement System	
Description	Rotary Measurement System	
	Model 2101	One-channel system
	Model 2102	Two-channel system
	Model 2103	Three-channel system
	Model 2104	Four-channel system
	Model 2105	Five-channel system
	Model 2106	Six-channel system
Accuracy	<0.25 % rated output	
Output	analog voltage 0 to 5, 0 to 10	
Temperature, Operating	Transmitter is -40 C to 85 C IPS and Receiver are -15 C to 65 C	
Temperature, Transmitter	0 °C to 85 °C [32 °F to 185 °F]	
Fits Shaft Sizes	50,8 mm to 1066,8 mm [2 in to 42 in]	

For more information, specifications, or to place an order, please visit us online at <http://measurementsensors.honeywell.com> or contact us at 800-848-6564 or +1 614-850-5000.

Wireless Telemetry

Clamp-on Measurement Systems



Honeywell's WDC series of clamp-on analog telemetry torque transducers measure torque on rotating machinery or propulsion systems where up-time is critical. These systems monitor very large motors (350 HP or above).

Clamp-on collars surround the shaft and provide digital readouts to display torque, RPM, and computed horsepower. A programmable alarm can be set so that the system can be shut down or scheduled for maintenance. Units can be sealed to work in harsh environments and areas of high vibration. Waterproof systems for marine environments are also available.

Honeywell's WDC series systems are highly customized to meet each unique application and operating environment. Please contact Honeywell for more information on the appropriate system to fit your particular situation.



Series	9300
Description	Model 9300 Clamp-on Rotary Torque Transducer System
Accuracy	<1 % rated output
Non-Linearity	±0.25 % rated output
Hysteresis	±0.10 % rated output
Repeatability	±0.05 % rated output
Output	analog voltage 0-5; 0-10
Temperature, Operating	0 °C to 85 °C [32 °F to 185 °F]
Temperature, Compensated	0 °C to 85 °C [32 °F to 185 °F]
Torsional Stiffness	0.125 in max.
Fits Shaft Sizes	From 63,5 mm to 392,17 mm [2.5 in to 15.4 in diameter]

For more information, specifications, or to place an order, please visit us online at <http://measurementsensors.honeywell.com> or contact us at 800-848-6564 or +1 614-850-5000.

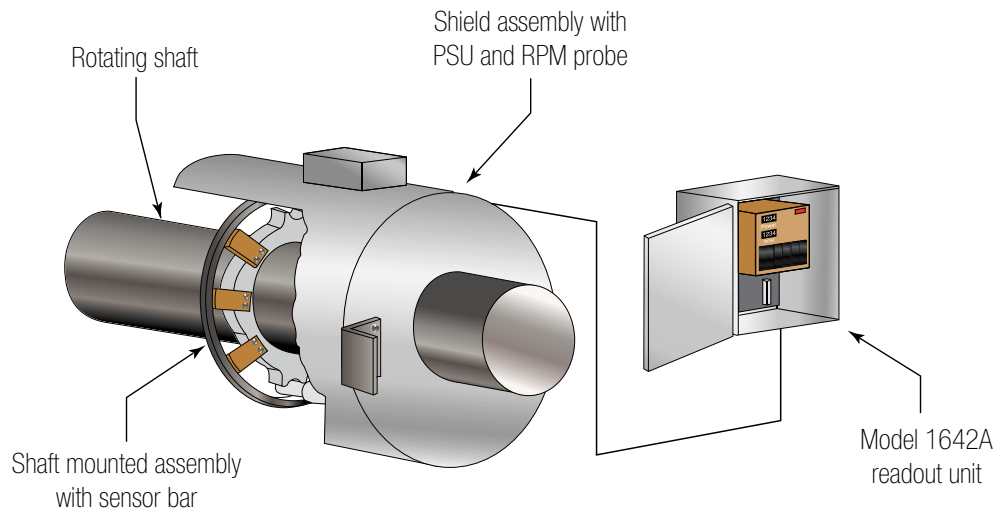

**Model 1602
system drawing**

1602A/1602A-01

- 1602A: Clamp-On Propulsion Monitoring System
- 1602A-01: Clamp-On Propulsion Monitoring System (torque measurement only)
- 1603A: Clamp-On Propulsion Monitoring System (without cover)
- 1603A-01: Clamp-On Propulsion Monitoring System (without cover) (torque measurement only)
- 1605: Clamp-On Horsepower Monitoring System

<1 % rated output

±0.25 % rated output

±0.10 % rated output

±0.05 % rated output

analog voltage 0 V to 5 V; 0 V to 10 V or current 4 mA to 20 mA

0 °C to 85 °C [32 °F to 185 °F]

21°C to 85 °C [70 °F to 185 °F]

0.125 in max.

1602 & 1605: From 381 mm to 762 mm [15 in to 30 in] in diameter

1603: From 63,5 mm to 391 mm [2.5 in to 15.4 in] in diameter

Features

- Measures torque, horsepower, and RPM
- Non-contact wireless telemetry technology transmits thermocouple data to a receiver
- RF modulation types include FSK and PWM - typical RF operating frequencies range up to 16 MHz
- Clamp-on torsionmeter
- Can be optimized to work in high vibration areas and tight spaces
- Custom options available

Typical Applications

- Marine: Propulsion system monitoring, hull and propeller fouling, load and balancing on twin screw vessels, fuel conservation programs
- Power plant equipment monitoring (turbines, etc.)
- Large industrial dryers and incinerators for waste disposal

Torque Transducers

Reaction - Flanged



Honeywell's flanged, reaction torque sensors are designed for installation between test pieces such as motors, switches, axles or shafts and their mounting plates. Each model utilizes four bonded strain gauges on a special-machined portion of the transducer to achieve a minimal non-linearity over a large dynamic range.

These models operate and are calibrated in both directions and are made of either stainless or nickel-plated alloy steel with no moving parts for enhanced durability in harsh, industrial environments.



Series	2102	2110	QFFH-9
Description	flange	flange	flange
Range	5,65 Nm to 112,98 Nm [50 lb-in to 1,000 lb-in]	225,97 Nm to 271163,59 Nm [2,000 lb-in to 2,400,000 lb-in]	338,95 Nm to 2711,64 Nm [3,000 in-lb to 24,000 in-lb]
Non-linearity	±0.1 % rated output	±0.1 % rated output	±0.1 % rated output
Hysteresis	±0.1 % rated output	±0.1 % rated output	±0.1 % rated output
Output	2.5 mV/V (nominal)	±2 mV/V (nominal)	±2 mV/V (nominal)
Temperature, operating	-54 °C to 93 °C [-65 °F to 200 °F]	-54 °C to 93 °C [-65 °F to 200 °F]	-54 °C to 107 °C [-65 °F to 225 °F]
Temperature, compensated	21 °C to 77 °C [70 °F to 170 °F]	21 °C to 77 °C [70 °F to 170 °F]	16 °C to 71 °C [60 °F to 160 °F]
Electrical termination	MS-3102E-14S-5P	MS-3102E-14S-5P	Bendix PTIH-10-6P or equivalent

Features

- 50 in-lb [5 Nm] up to 2,400,000 in-lb [271,000 Nm] capacities
- 0.1 % non-linearity and hysteresis
- Low-end-sensitivity due to absence of moving parts
- Wide dynamic range

Typical Applications

- Tire braking
- Motor dynamometers
- Friction-skid testing
- Twist measurement
- Structural endurance
- Component or product testing

For more information, specifications, or to place an order, please visit us online at <http://measurementsensors.honeywell.com> or contact us at 800-848-6564 or +1 614-850-5000.

Torque Transducers

Reaction - Special Configurations



Honeywell offers a series of hollow, reaction torque sensors designed for reaction force measurement in mixing, hydraulic pump and motor test applications. These models operate and are calibrated in both directions, utilizing four bonded strain gauges on a special-machined portion of the transducer to achieve a maximum non-linearity of 0.1 % over a wide dynamic range. The nickel-plated alloy steel construction, with no moving parts, enhances durability in harsh industrial environments.



Series	2404	2320
Description	hollow reaction	flanged reaction
Range	5,6 Nm to 564,9 Nm [50 lb-in to 5000 lb-in]	1355,8 Nm [12,000 lb-in], 4067 Nm [36,000 lb-in]
Non-linearity	±0.1 % rated output	±0.1 % rated output
Hysteresis	±0.1 % rated output	±0.1 % rated output
Output	1.5 mV/V (nominal)	±2 mV/V (nominal)
Temperature, operating	-54 °C to 93 °C [-65 °F to 200 °F]	-54 °C to 93 °C [-65 °F to 200 °F]
Temperature, compensated	21 °C to 77 °C [70 °F to 170 °F]	21 °C to 77 °C [70 °F to 170 °F]
Electrical termination	MS-3102E-14S-5P	MS-3102E-14S-5P

Features

- 50 in-lb [5,6 Nm] up to 36,000 in-lb [4067 Nm] capacities
- 0.1 % non-linearity and hysteresis
- High torsional stiffness
- High resistance to bending moments
- Low-end sensitivity due to absence of moving parts

Typical Applications

- Mixing applications
- Viscosity measurement
- Hydraulic pump and motor testing
- Dynamometer testing

For more information, specifications, or to place an order, please visit us online at <http://measurementsensors.honeywell.com> or contact us at 800-848-6564 or +1 614-850-5000.

Torque Transducers

Reaction - Miniature



Honeywell's miniature, low capacity, reaction torque sensors are designed and engineered to fit into small spaces with tight clearances, yet still provide highly accurate torque measurements. These sensors are made of modular stainless steel, aluminum, or nickel-plated alloy steel with no moving parts for excellent durability under harsh industrial conditions.

Each sensor has four bonded strain gauges positioned on a special-machined portion of the transducer to effectively measure even slight torque loads to achieve a minimal non-linearity over a large dynamic range.



Series	2105	QWFK-8M	QWLC-8M
Description	miniature	miniature	miniature
Range	0,35 Nm to 7,06 Nm [50 oz-in to 1,000 oz-in]	0,18 Nm to 1,77 Nm [25 in-oz to 250 in-oz] 5,6 Nm to 33,9 Nm [50 in-lb to 300 in-lb]	0,18 Nm to 1,77 Nm [25 in-oz to 250 in-oz] 5,6 Nm to 33,9 Nm [50 in-lb to 300 in-lb]
Non-linearity	±0.1 % rated output	±0.1 % rated output	±0.1 % rated output
Hysteresis	±0.1 % rated output	±0.1 % rated output	±0.1 % rated output
Output	±2 mV/V (nominal)	±2 mV/V (nominal)	±2 mV/V (nominal)
Temperature, operating	-54 °C to 93 °C [-65 °F to 200 °F]	-54 °C to 107 °C [-65 °F to 225 °F]	-54 °C to 107 °C [-65 °F to 225 °F]
Temperature, compensated	21 °C to 77 °C [70 °F to 170 °F]	16 °C to 71 °C [60 °F to 160 °F]	16 °C to 71 °C [60 °F to 160 °F]
Electrical termination	PT02H-10-6P	Teflon cable (1.5 m [5 ft])	Teflon cable (1.5 m [5 ft])

Features

- 25 in-oz [0,18 Nm] up to 300 in-lb [34 Nm] capacities
- 0.1 % non-linearity and hysteresis
- Compact size
- High frequency response
- Stainless steel construction
- No maintenance of slip rings, bearings or brushes

Typical Applications

- Twist measurement
- Small component and product testing
- Switch testing

For more information, specifications, or to place an order, please visit us online at <http://measurementsensors.honeywell.com> or contact us at 800-848-6564 or +1 614-850-5000.

Torque Transducers

Reaction - Shaft



Honeywell's shaft reaction torque sensors are designed for installation between test pieces, such as motors, switches, axles or shafts and their mounting plates. These models operate and are calibrated in both directions. They are constructed of either stainless or nickel-plated alloy steel with no moving parts for enhanced durability in harsh industrial environments.



Series	2120 Low	2120	QSFK-9
Description	shaft	shaft	shaft
Range	0,35 Nm to 7,06 Nm [50 oz-in to 1,000 oz-in]	11,3 Nm to 56492,4 Nm [100 lb-in to 500,000 lb-in]	[11,3 Nm to 2711,6 Nm] 100 in-lb to 24,000 in-lb
Accuracy	0.15 % rated output	0.15 % rated output	±0.15 % rated output
Non-linearity	±0.1 % rated output	±0.1 % rated output	±0.1 % rated output
Hysteresis	±0.1 % rated output	±0.1 % rated output	±0.1 % rated output
Output	±2 mV/V (nominal)	±2 mV/V (nominal)	±2 mV/V (nominal)
Temperature, operating	-54 °C to 93 °C [-65 °F to 200 °F]	-54 °C to 93 °C [-65 °F to 200 °F]	-54 °C to 107 °C [-65 °F to 225 °F]
Temperature, compensated	21 °C to 77 °C [70 °F to 170 °F]	21 °C to 77 °C [70 °F to 170 °F]	16 °C to 71 °C [60 °F to 160 °F]
Electrical termination	PT02H-10-6P	MS-3102E-14S-5P	MS3102A-14S-6P or equivalent

Features

- 50 in-oz [0,35 Nm] to 1,000 in-oz [7 Nm] or 100 in-lb [10 Nm] to 500,000 in-lb [56500 Nm] capacities
- 0.1 % non-linearity and hysteresis
- Wide dynamic range
- Stainless steel or nickel-plated alloy construction
- No maintenance of slip rings, bearings or brushes
- High frequency response
- Low-end sensitivity

Typical Applications

- Tire braking
- Motor dynamometers
- Friction-skid testing
- Twist measurement
- Stall torque
- Component and product testing

For more information, specifications, or to place an order, please visit us online at <http://measurementsensors.honeywell.com> or contact us at 800-848-6564 or +1 614-850-5000.

Torque Transducers

Reaction - Square Drive



Honeywell's reaction, square drive sensors are primarily used in torque wrench calibration applications, such as socket-wrench torque monitoring, where repeatable torque measurements are needed. They are cost-effective and adaptable for portable usage, with no special adapter tools required. These sensors may also be used in a production line, assembly line, stall nut-runner setup and calibration.



Series	2133-300
Description	square drive
Range	0,42 Nm [10 lb-ft], 0,84 Nm [20 lb-ft], 2,11 Nm [50 lb-ft], 4,21 Nm [100 lb-ft], 10,5 Nm [250 lb-ft], 25,3 Nm [600 lb-ft], 42,1 Nm [1,000 lb-ft]
Accuracy	0.37 % rated output
Non-linearity	±0.25 % rated output
Hysteresis	±0.25 % rated output
Output	±2 mV/V (nominal)
Temperature, operating	-54 °C to 93 °C [-65 °F to 200 °F]
Temperature, compensated	21 °C to 77 °C [70 °F to 170 °F]

Features

- 10 ft-lb to 1,000 ft-lb capacities
- 0.25 % non-linearity and hysteresis
- Adaptable for portable usage
- No special adapter tools required
- Repeatable torque measurements

Typical Applications

- Production line/assembly line stall nutrunner set-up, calibration, and verification
- Socket wrench torque monitoring
- Calibration reference for "hard usage" mechanical torque wrenches

For more information, specifications, or to place an order, please visit us online at <http://measurementsensors.honeywell.com> or contact us at 800-848-6564 or +1 614-850-5000.

Torque Transducers

Reaction - Torque Thrust



Honeywell's Model 6400 series reaction torque-thrust transducers are used to sense both torque and thrust parameters simultaneously. These torque sensors are constructed of one-piece, nickel-plated alloy steel and are designed specifically to provide the strength and rigidity required to withstand extraneous loads and bending moments. The unique construction also provides both maximum structure life and minimum thrust/torque crosstalk.



Series	6400
Description	thrust
Range	101,7 Nm/ 1,500 lb to 11 298,5 Nm/ 200,000 lb [900 lb-in/1,500 lb to 100,000 lb-in/200,000 lb]
Accuracy	0.23 % rated output
Non-linearity	±0.15 % rated output
Hysteresis	±0.15 % rated output
Output	1.5 mV/V (nominal)
Temperature, operating	-54 °C to 93 °C [-65 °F to 200 °F]
Temperature, compensated	21 °C to 77 °C [70 °F to 170 °F]
Electrical termination	MS-3102E-14S-5P

Features

- 900 in-lb/1,500 lb to 100,000 in-lb/200,000 lb (standard)
- 0.15 % non-linearity and hysteresis
- Reduced crosstalk
- Extraneous load resistance
- Single piece construction
- Fatigue rated

Typical Applications

- Material testing
- Geological drilling or boring applications
- Component endurance testing
- Structural integrity testing

For more information, specifications, or to place an order, please visit us online at <http://measurementsensors.honeywell.com> or contact us at 800-848-6564 or +1 614-850-5000.

Torque Transducers

Reaction - Torque Watch



Honeywell offers a series of torque watch gauges for measurement of very low, low static, and high range torque. Each model features internal stainless steel rotation stops which help prevent damage from over-torque up to two times the normal range (three times the normal range for the low range series). All models are simple to use and can measure torque in either a clockwise or counter-clockwise direction.



Series	366	651	940
Description	low range	mid range	high range
Range	0.003 oz-in to 0.6 oz-in 0.2 g-cm to 42 g-cm	0.5 oz-in to 10 oz-in 2.8 gm-cm to 600 gm-cm	15 oz-in to 200 oz-in 1 Kgm-cm to 14 Kgm-cm 0.1 Nm to 1.4 Nm
Accuracy	±5 %, ±10 % rated output	±2 % rated output	±2 % rated output

Features

- Accurate measurement of high range, low static, or very low torque
- Accuracy ranges from 2 %, 5 % and 10 % depending on model
- Measures torque in either a clockwise or counter-clockwise direction
- Keyed chuck or square socket driver adapter
- Dial indication
- Overload protection

Typical Applications

- Production assembly line
- Quality assurance

For more information, specifications, or to place an order, please visit us online at <http://measurementsensors.honeywell.com> or contact us at 800-848-6564 or +1 614-850-5000.

Torque Transducers

Accessories and Special Order Products



Honeywell provides a wide range of accessories for our test and measurement sensor products, which are designed to meet additional requirements for most customer applications.

TEST & MEASUREMENT ACCESSORIES

- Optional speed sensing available
- Passive magnetic pickups
- Zero velocity pickups
- Footmounts
- Cables
- Signal conditioning/readout devices
- Calibration arms

Additional Torque Models Available

Series	Description	Capacity	Features
1641	Rotary Torque: Non-contact, unamplified, flange mount	2250 Nm to 11300 Nm [20000 lb-in to 100000 lb-in]	<ul style="list-style-type: none"> • Shortened drive length • Extended speed range • Minimal maintenance due to “bearings only” contact • High performance accuracy
1648	Rotary Torque: Non-contact, unamplified, flange mount	225 Nm to 1130 Nm [2000 lb-in to 10000 lb-in]	<ul style="list-style-type: none"> • Shortened drive length • Extended speed range • Minimal maintenance due to “bearings only” contact • High performance accuracy
1615K	Rotary Torque: Slip ring, special application	5,6 Nm to 1130 Nm [50 lb-in to 10000 lb-in]	<ul style="list-style-type: none"> • Conforms to Army/Navy mounting standards
1228	Rotary Torque: Slip ring, flange mount	225 Nm to 1130 Nm [2000 lb-in to 10000 lb-in]	<ul style="list-style-type: none"> • Special application flanges • Short drive length • An industry military standard for pump and driveline testing
1248	Rotary Torque: Slip ring, flange mount	2250 Nm [20000 lb-in]	<ul style="list-style-type: none"> • Special application flanges • Short drive length • An industry military standard for pump and driveline testing

Warranty/Remedy

Honeywell warrants goods of its manufacture as being free of defective materials and faulty workmanship. Honeywell's standard product warranty applies unless agreed to otherwise by Honeywell in writing; please refer to your order acknowledgment or consult your local sales office for specific warranty details. If warranted goods are returned to Honeywell during the period of coverage, Honeywell will repair or replace, at its option, without charge those items it finds defective.

The foregoing is buyer's sole remedy and is in lieu of all other warranties, expressed or implied, including those of merchantability and fitness for a particular purpose. In no event shall Honeywell be liable for consequential, special, or indirect damages.

While we provide application assistance personally, through our literature and the Honeywell web site, it is up to the customer to determine the suitability of the product in the application.

Specifications may change without notice. The information we supply is believed to be accurate and reliable as of this printing. However, we assume no responsibility for its use.

Find out more

Honeywell serves its customers through a worldwide network of sales offices, representatives and distributors. For application assistance, current specifications, pricing or name of the nearest Authorized Distributor, contact your local sales office.

To learn more about Honeywell's test and measurement products, call **+1-614-850-5000**, visit

<http://measurementsensors.honeywell.com>,

or e-mail inquiries to **info.tm@honeywell.com**

Sensing and Control

Honeywell

1985 Douglas Drive North
Golden Valley, MN 55422

honeywell.com

The Honeywell logo is displayed in a bold, red, sans-serif font.