



Chipsmall Limited consists of a professional team with an average of over 10 year of expertise in the distribution of electronic components. Based in Hongkong, we have already established firm and mutual-benefit business relationships with customers from,Europe,America and south Asia,supplying obsolete and hard-to-find components to meet their specific needs.

With the principle of “Quality Parts,Customers Priority,Honest Operation,and Considerate Service”,our business mainly focus on the distribution of electronic components. Line cards we deal with include Microchip,ALPS,ROHM,Xilinx,Pulse,ON,Everlight and Freescale. Main products comprise IC,Modules,Potentiometer,IC Socket,Relay,Connector.Our parts cover such applications as commercial,industrial, and automotives areas.

We are looking forward to setting up business relationship with you and hope to provide you with the best service and solution. Let us make a better world for our industry!



## Contact us

Tel: +86-755-8981 8866 Fax: +86-755-8427 6832

Email & Skype: info@chipsmall.com Web: www.chipsmall.com

Address: A1208, Overseas Decoration Building, #122 Zhenhua RD., Futian, Shenzhen, China



REVISIONS					
REV	ECO	DESCRIPTION	DATE	BY	APPR
A1	--	RELEASED DRAWING	Mar-18-2016	Ben	Tommy

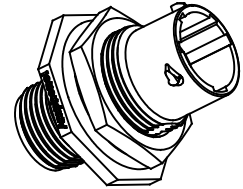
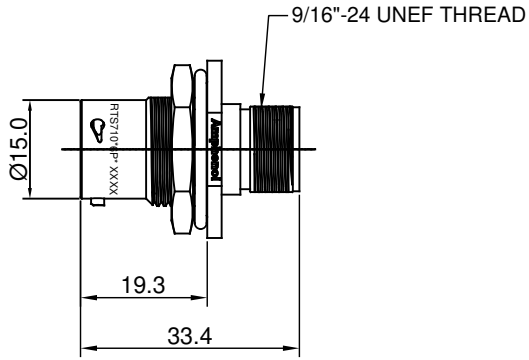
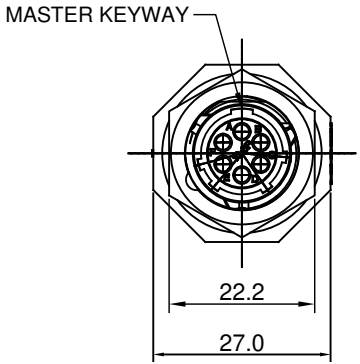

NOTES : (UNLESS OTHERWISE SPECIFIED)

- MATERIAL :
  - SHELL : THERMOPLASTIC , UL94 V-0.
  - INSERT : THERMOPLASTIC , UL94 V-0.
  - O-RING : NBR/SILICONE RUBBER.
  - SEAL GASKET : NBR/SILICONE RUBBER.
  - JAM NUT : AL ALLOY , BLACK ANODIZING.
- SPECIFICATIONS :
  - 2.1 RATED CURRENT :
    - 2.1.1 STAMPED CONTACT 5A (MAX).
    - 2.1.2 MACHINED CONTACT 7.5A (MAX).
  - 2.2 RATED VOLTAGE : 250V(AC/DC).
  - 2.3 OPERATING TEMPERATURE : SEE CHART.
  - 2.4 DIELECTRIC WITHSTANDING VOLTAGE : LESS THAN 2 MILLIAMPS CURRENT LEAKAGE@1500 VOLTS AC.
  - 2.5 INSULATION RESISTANCE : 5000 MEGOHMS MIN.
  - 2.6 IP--CLASS : IP67.
  - 2.7 MATING CYCLES DURABILITY : 500 CYCLES MIN.
  - 2.8 RoHS COMPLIANT.
- SUITABLE CONTACTS : 20# CONTACTS.
- ALL DIMENSIONS ARE FOR REFERENCE USE ONLY.

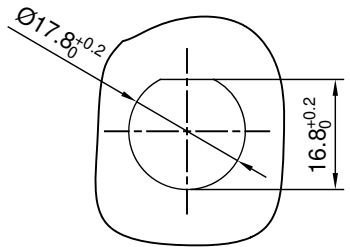

PANEL CUT OUT REFERENCE

KEY	PART NUMBER	
	-40°C ~ 105°C	-40°C ~ 125°C
N	RTS710N6P	RTS710N6P03

QUANTITY	PART NUMBER	DESCRIPTION	ITEM										
<b>MATERIALS LIST</b>													
<small>UNLESS OTHERWISE SPECIFIED</small> 1) All dimensions are in metric(mm). 2) Tolerances are as follows: 1 PL DEC ±0.30    Fractions: ±1/64 2 PL DEC ±0.15    Angles: ±1° 3 PL DEC ±0.08 3) Note reference =		<table border="1"> <tr> <th>SIGNATURES</th> <th>DATE</th> </tr> <tr> <td>DRAWN: Ben</td> <td>Mar-18-2016</td> </tr> <tr> <td>CHECKED: Tod</td> <td>Mar-18-2016</td> </tr> <tr> <td>ENGINEER:</td> <td></td> </tr> <tr> <td>APPROVAL: Tommy</td> <td>Mar-18-2016</td> </tr> </table>	SIGNATURES	DATE	DRAWN: Ben	Mar-18-2016	CHECKED: Tod	Mar-18-2016	ENGINEER:		APPROVAL: Tommy	Mar-18-2016	<div style="text-align: center;"> <h1>Amphenol</h1> <p>Sine Systems - <a href="http://www.amphenol-sine.com">www.amphenol-sine.com</a>            44724 Morley Drive            Clinton Township, MI 48036</p> </div>
SIGNATURES	DATE												
DRAWN: Ben	Mar-18-2016												
CHECKED: Tod	Mar-18-2016												
ENGINEER:													
APPROVAL: Tommy	Mar-18-2016												
<small>MATERIAL SPECIFICATIONS:</small>  <small>PROCESS SPECIFICATIONS:</small>  <small>NEXT ASSY:</small>		<small>CUSTOMER:</small> ECO-MATE, RECEPTACLE, JAM NUT, SIZE 10, 6POS, PIN.	<table border="1"> <tr> <th>SIZE</th> <th>TYPE</th> <th>DWG NO.</th> <th>REVISION</th> </tr> <tr> <td>B</td> <td>C-</td> <td>RTS710*6P*</td> <td>A1</td> </tr> </table>	SIZE	TYPE	DWG NO.	REVISION	B	C-	RTS710*6P*	A1		
SIZE	TYPE	DWG NO.	REVISION										
B	C-	RTS710*6P*	A1										
		SCALE: NONE	SHEET 1 OF 1										

TITLE: ECO-MATE, RECEPTACLE, JAM NUT, SIZE 10, 6POS, PIN.    DWG NO.: RTS710\*6P\*    REV: A1    SH: 1    OF: 1