



Chipsmall Limited consists of a professional team with an average of over 10 year of expertise in the distribution of electronic components. Based in Hongkong, we have already established firm and mutual-benefit business relationships with customers from,Europe,America and south Asia,supplying obsolete and hard-to-find components to meet their specific needs.

With the principle of “Quality Parts,Customers Priority,Honest Operation,and Considerate Service”,our business mainly focus on the distribution of electronic components. Line cards we deal with include Microchip,ALPS,ROHM,Xilinx,Pulse,ON,Everlight and Freescale. Main products comprise IC,Modules,Potentiometer,IC Socket,Relay,Connector.Our parts cover such applications as commercial,industrial, and automotives areas.

We are looking forward to setting up business relationship with you and hope to provide you with the best service and solution. Let us make a better world for our industry!



Contact us

Tel: +86-755-8981 8866 Fax: +86-755-8427 6832

Email & Skype: info@chipsmall.com Web: www.chipsmall.com

Address: A1208, Overseas Decoration Building, #122 Zhenhua RD., Futian, Shenzhen, China



THIS DRAWING IS UNPUBLISHED. RELEASED FOR PUBLICATION 20
 © COPYRIGHT 2002 BY TYCO ELECTRONICS CORPORATION. ALL RIGHTS RESERVED.

LOC	DIST	REVISIONS			
P	LTR	DESCRIPTION	DATE	DWN	APVD
J	-	B	REVISED	30MAR2010	Y. H Y. N

- 1 ; 本図
 - 1 ; AS SHOWN

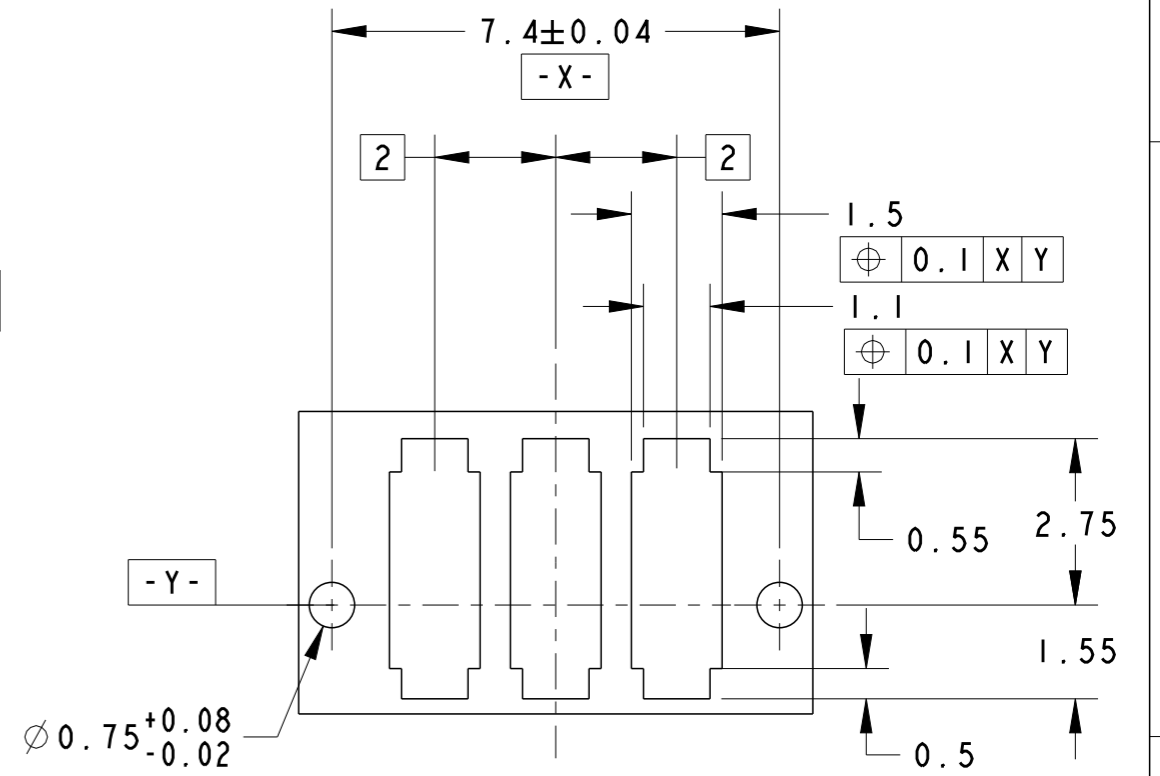
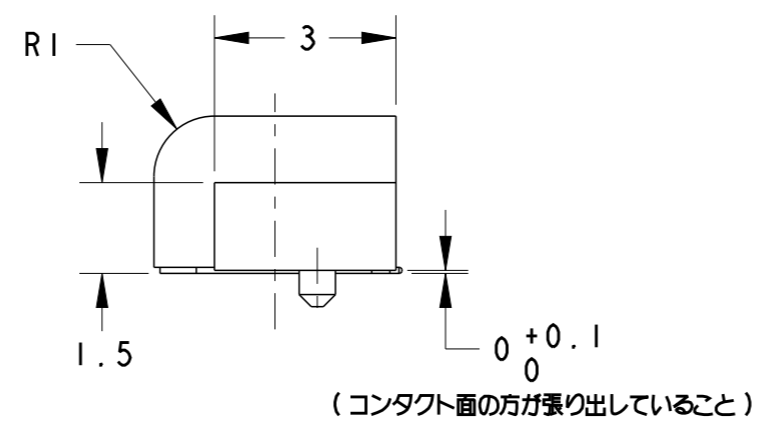
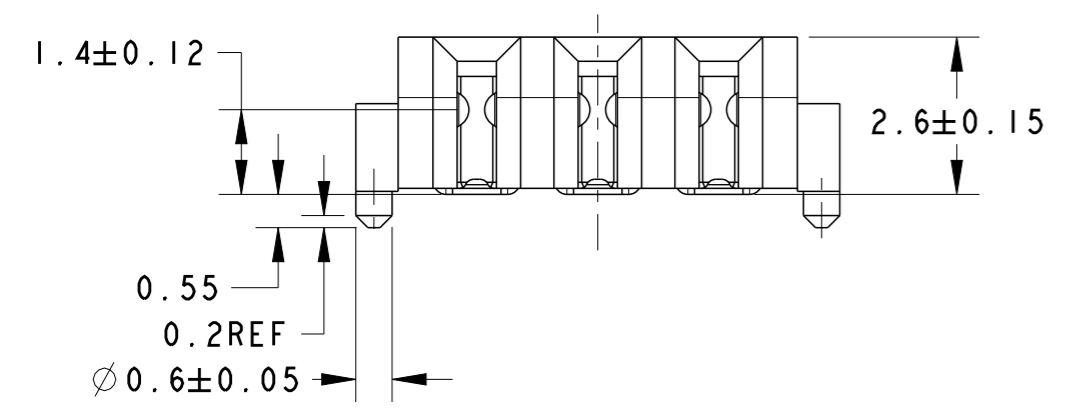
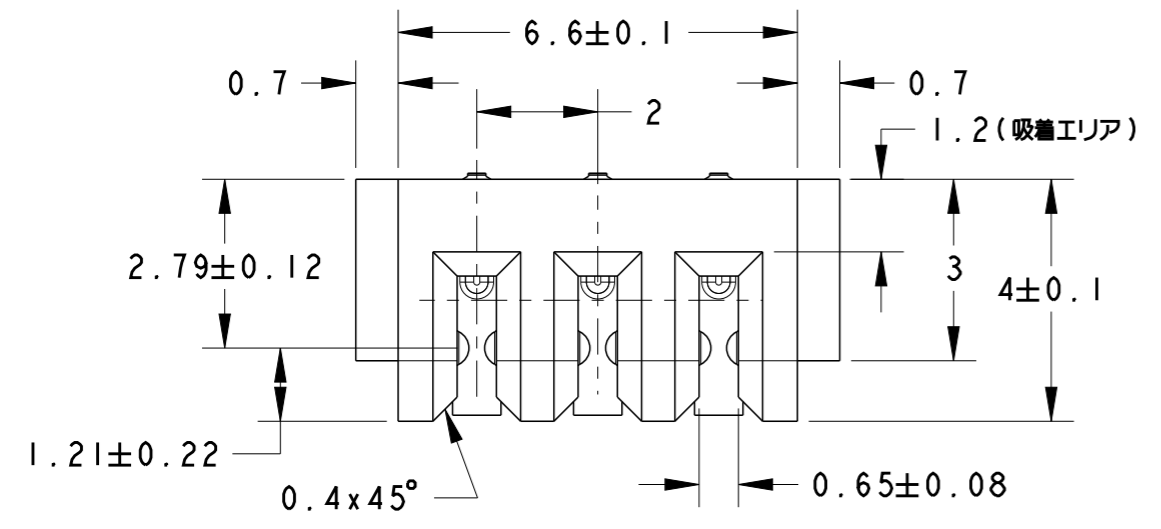
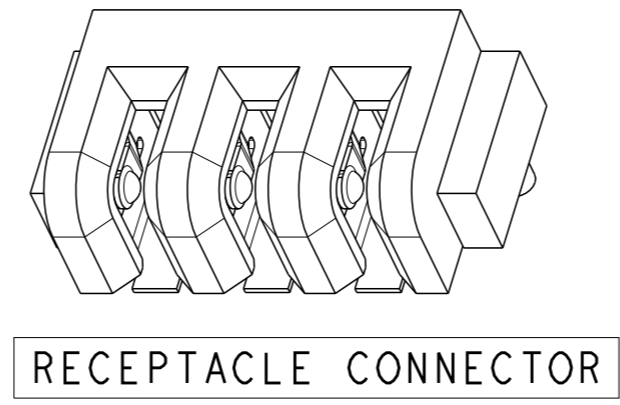

- 1 材料
ハウジング; 熱可塑性樹脂, UL 94V-0, 黒
コンタクト; 銅合金
- 2 仕上げ
コンタクト; 全面ニッケル下地めっき
接触部; 金めっき
半田付け部; 金フラッシュ
- 1 MATERIAL
HOUSING; THERMOPLASTIC RESIN, UL94V-0, BLACK
CONTACT; COPPER ALLOY
- 2 FINISH
CONTACT; ALL OVER Ni UNDER PLATING.
CONTACT AREA: GOLD PLATING
SOLDERING AREA: GOLD FLASH

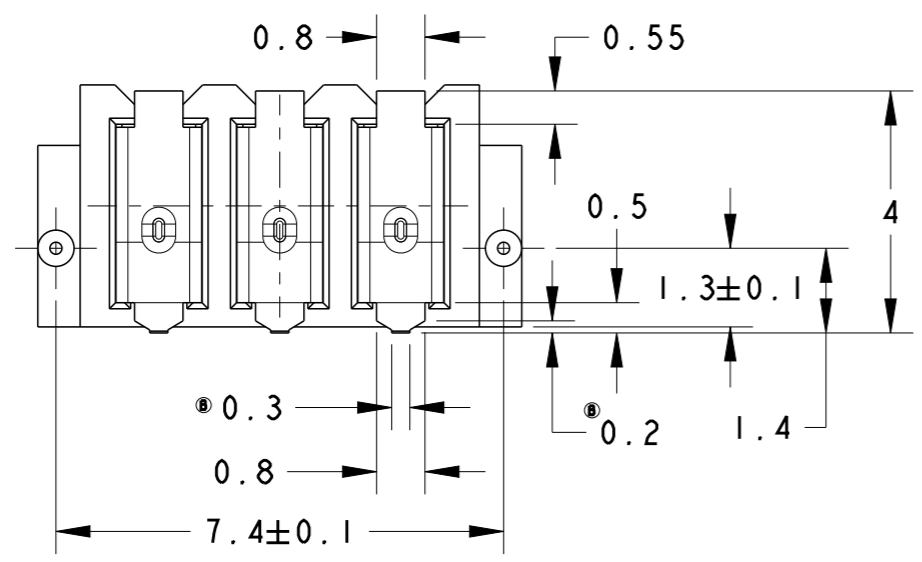

THIS DRAWING IS A CONTROLLED DOCUMENT FOR TYCO ELECTRONICS CORPORATION. IT IS SUBJECT TO CHANGE AND THE CONTROLLING ENGINEERING ORGANIZATION SHOULD BE CONTACTED FOR THE LATEST REVISION.		DWN C. OHASHI 20SEP2002	Tyco Electronics Corporation. Kawasaki, Japan	
		CHK K. Ikegami 25SEP2002		
		APVD K. KODAIRA 25SEP2002		
DIMENSIONS: mm		PRODUCT SPEC 108-5846	NAME BATTERY BLOCK CONNECTOR RECEPTACLE ASSY 3POS 2MM PITCH	
TOLERANCES UNLESS OTHERWISE SPECIFIED: 0 PLC ±0.2 1 PLC ±0.2 2 PLC ±0.2 3 PLC ±0.2 4 PLC ±0.2 ANGLES ±2		APPLICATION SPEC	SIZE A3	CAGE CODE 00779
MATERIAL 1		FINISH 2	DRAWING NO C-1612901	RESTRICTED TO -
		WEIGHT 0.12g	SCALE 8/1	SHEET 1 OF 2
		CUSTOMER DRAWING	REV B	

THIS DRAWING IS UNPUBLISHED. RELEASED FOR PUBLICATION 20
 © COPYRIGHT 2002 BY TYCO ELECTRONICS CORPORATION. ALL RIGHTS RESERVED.

LOC	DIST	REVISIONS					
		P	LTR	DESCRIPTION	DATE	DWN	APVD
J	-		-	SEE SHEET 1			

テープ引き出し方向
 DIRECTION OFF TOP OF REEL

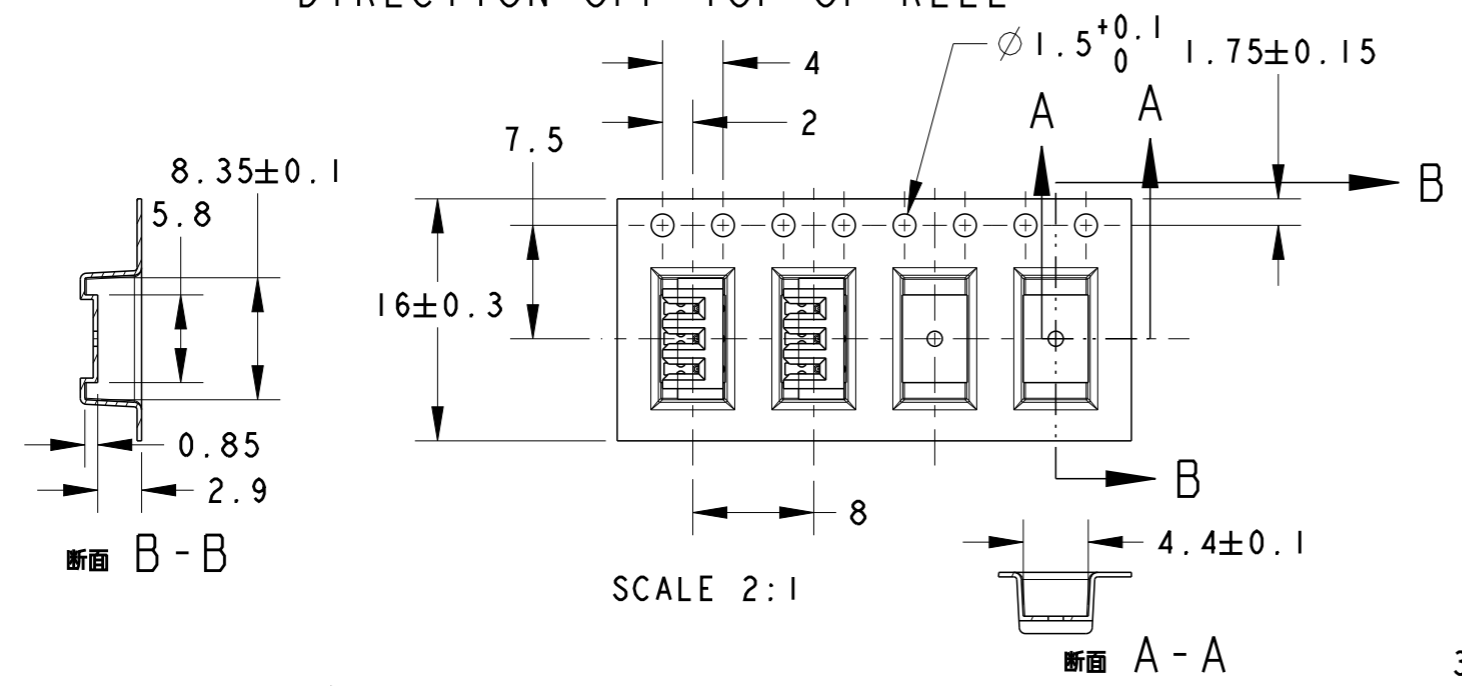

SCALE 2:1

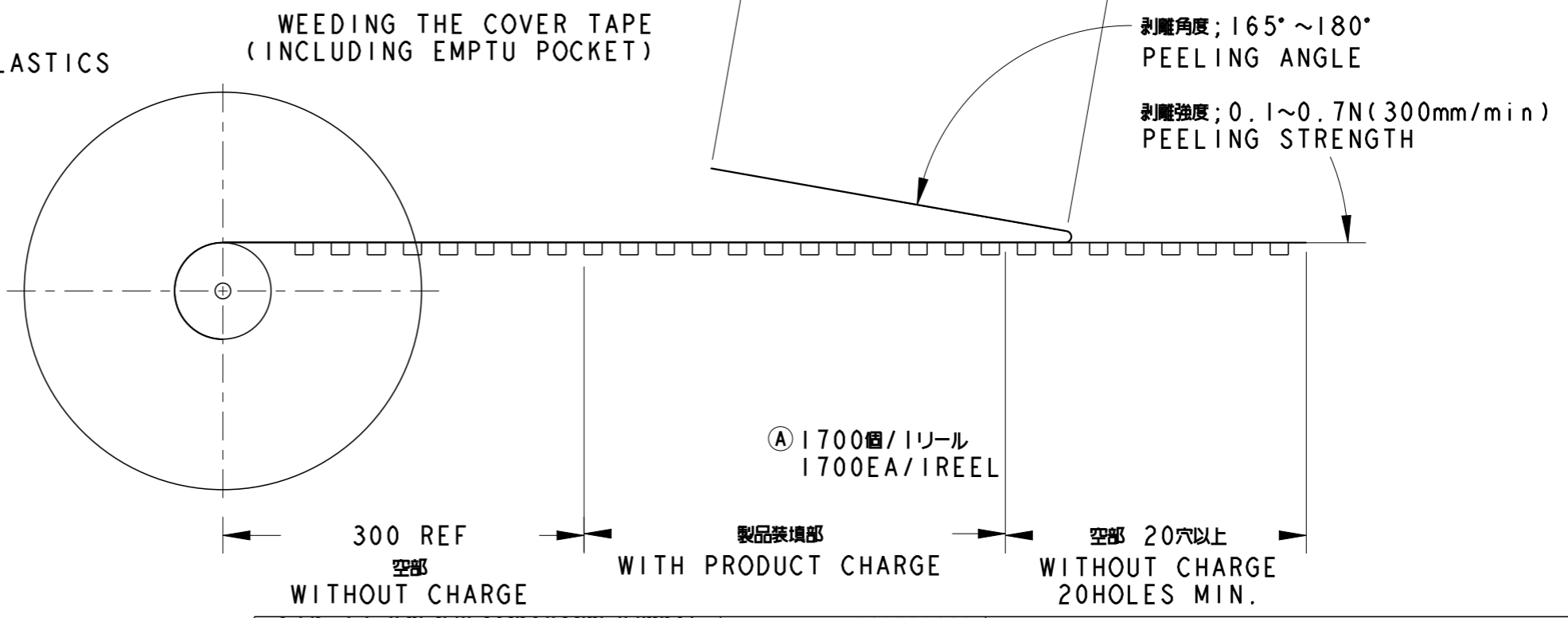
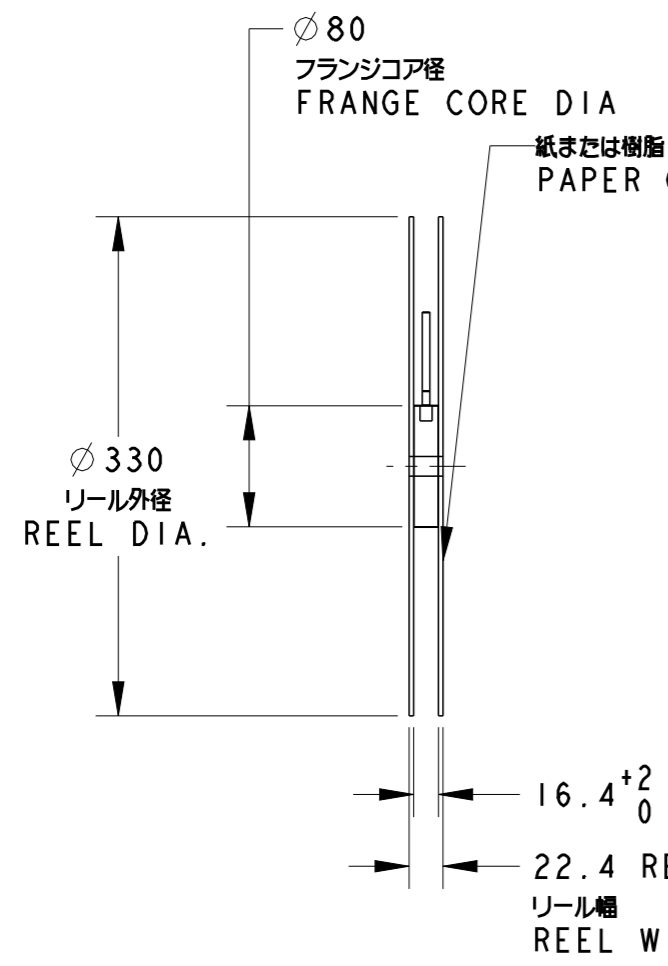

① 1700個/1リール
 1700EA/1REEL

<small>THIS DRAWING IS A CONTROLLED DOCUMENT FOR TYCO ELECTRONICS CORPORATION IT IS SUBJECT TO CHANGE AND THE CONTROLLING ENGINEERING ORGANIZATION SHOULD BE CONTACTED FOR THE LATEST REVISION.</small>		DWN 20SEP2002 C. OHASHI CHK 25SEP2002 K. IKEGAMI APVD 25SEP2002 K. KODAIRA PRODUCT SPEC 108-5846 APPLICATION SPEC		Tyco Electronics Tyco Electronics Corporation. Kawasaki, Japan	
DIMENSIONS: mm 		TOLERANCES UNLESS OTHERWISE SPECIFIED: 0 PLC ±0.2 1 PLC ±0.2 2 PLC ±0.2 3 PLC ±0.2 4 PLC ±0.2 ANGLES ±2 FINISH		NAME BATTERY BLOCK CONNECTOR REEPTACLE ASSY 3POS 2MM PITCH	
MATERIAL		WEIGHT 0.12g		SIZE A3	CAGE CODE 00779
		CUSTOMER DRAWING		DRAWING NO. C-1612901	RESTRICTED TO -
				SCALE 8/1	SHEET 2 OF 2
				REV B	