



Chipsmall Limited consists of a professional team with an average of over 10 year of expertise in the distribution of electronic components. Based in Hongkong, we have already established firm and mutual-benefit business relationships with customers from,Europe,America and south Asia,supplying obsolete and hard-to-find components to meet their specific needs.

With the principle of “Quality Parts,Customers Priority,Honest Operation,and Considerate Service”,our business mainly focus on the distribution of electronic components. Line cards we deal with include Microchip,ALPS,ROHM,Xilinx,Pulse,ON,Everlight and Freescale. Main products comprise IC,Modules,Potentiometer,IC Socket,Relay,Connector.Our parts cover such applications as commercial,industrial, and automotives areas.

We are looking forward to setting up business relationship with you and hope to provide you with the best service and solution. Let us make a better world for our industry!



Contact us

Tel: +86-755-8981 8866 Fax: +86-755-8427 6832

Email & Skype: info@chipsmall.com Web: www.chipsmall.com

Address: A1208, Overseas Decoration Building, #122 Zhenhua RD., Futian, Shenzhen, China



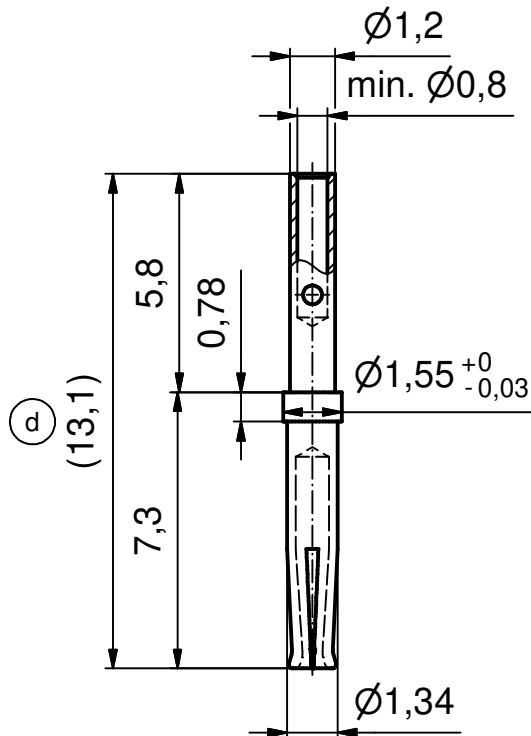
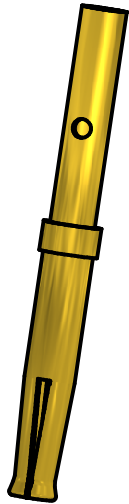

STRIPPING DIMENSION (b) (d)

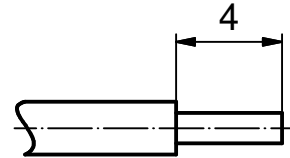

Part-no. as per finish		
(d) GOLD FLASH over NICKEL (e)	min. 20µm HARD GOLD over min. 50µm NICKEL	min. 30µm HARD GOLD over min. 50µm NICKEL
162A18419X	162B18419X	162C18419X

(b) (c) (d) **NOTES:**

1. Material: Copper alloy
2. Finish: See table
3. Temperature range: -55 °C to +125 °C
4. Rated current: 3 A maximum
5. Contact resistance: <= 10 mOhm
6. Crimping: Use crimp tool 360X10329X
With tool insert 360X10629X
Selector settings: 4 for AWG 22
3 for AWG 24
2 for AWG 26
1 for AWG 28

Directive 2002/95/EC RoHS compliant

THIS DRAWING MAY NOT BE COPIED OR REPRODUCED IN ANY WAY, AND MAY NOT BE PASSED ON TO A THIRD PARTY WITHOUT WRITTEN PERMISSION. OWNERSHIP AND COPYRIGHT OF CONEC GmbH

DO NOT ALTER CAD DRAWING BY HAND

				tolerance	dim. in mm		
				DIN ISO 2768-m			
				date	name		
				drawn 12.03.01	Parei		
1 x e	Ä 4116	26.09.11	Lehm.	appd. 12.03.01	Mickenbecker		
4 x d	Ä 3698	25.08.10	Lehm.	norm			
1 x c	Ä 3679	24.06.10	Petker	d-old			
2 x b	Ä 2647	11.01.07	Lehm.				
a	Original						
rev.	description	date	name				

scale:	5:1	
material:	SEE NOTES	
title:	HD CRIMP SOCKET CONTACT screw machined version accepts cable AWG 28-22	
dwg no:	Inventor 10	DIN-A4
	16K1A153A	sh: 1
part no:	SEE TABLE	