



Chipsmall Limited consists of a professional team with an average of over 10 year of expertise in the distribution of electronic components. Based in Hongkong, we have already established firm and mutual-benefit business relationships with customers from,Europe,America and south Asia,supplying obsolete and hard-to-find components to meet their specific needs.

With the principle of “Quality Parts,Customers Priority,Honest Operation,and Considerate Service”,our business mainly focus on the distribution of electronic components. Line cards we deal with include Microchip,ALPS,ROHM,Xilinx,Pulse,ON,Everlight and Freescale. Main products comprise IC,Modules,Potentiometer,IC Socket,Relay,Connector.Our parts cover such applications as commercial,industrial, and automotives areas.

We are looking forward to setting up business relationship with you and hope to provide you with the best service and solution. Let us make a better world for our industry!



Contact us

Tel: +86-755-8981 8866 Fax: +86-755-8427 6832

Email & Skype: info@chipsmall.com Web: www.chipsmall.com

Address: A1208, Overseas Decoration Building, #122 Zhenhua RD., Futian, Shenzhen, China



DO NOT SCALE

DIMENSIONS IN mm

METRIC

THIRD ANGLE
PROJECTION

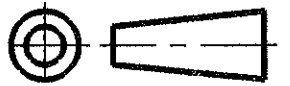

NOTES:

- 1 FOR USE ON MINIATURE APPLICATOR (LEFT-RIGHT FEED).
- 2 FOR USE ON STANDARD APPLICATOR (RIGHT-LEFT FEED)
- 3 FOR LOOSE-PIECE VERSIONS SEE DWG. 164169.
- 4 UNDERCOATING: 1,3µm Ni.
SELECTIVE : 0,8µm Au.
ZONE I : BRIGHT TIN/LEAD PLATED
- 5 UNDERCOATING: 1,27µm Ni.
SELECTIVE : 2,0µm Au.
REMAINDER : GOLDFLASH.
- 6 UNDERCOATING: 1,3µm Ni.
SELECTIVE : 0,8µm Au.
REMAINDER : GOLDFLASH.

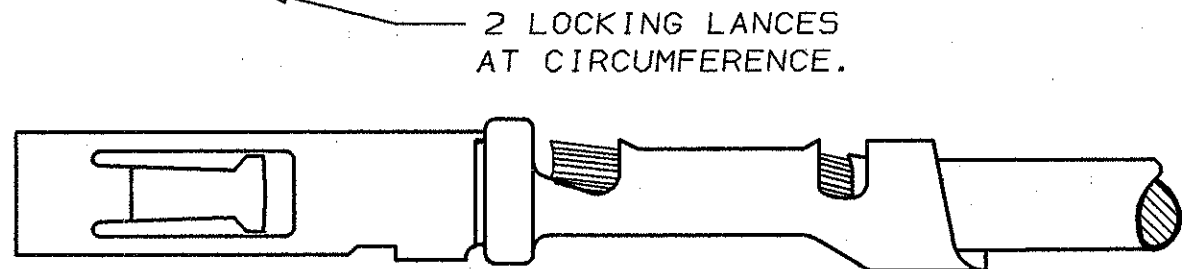
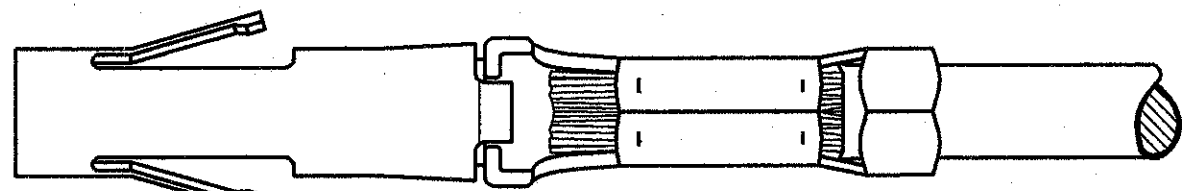
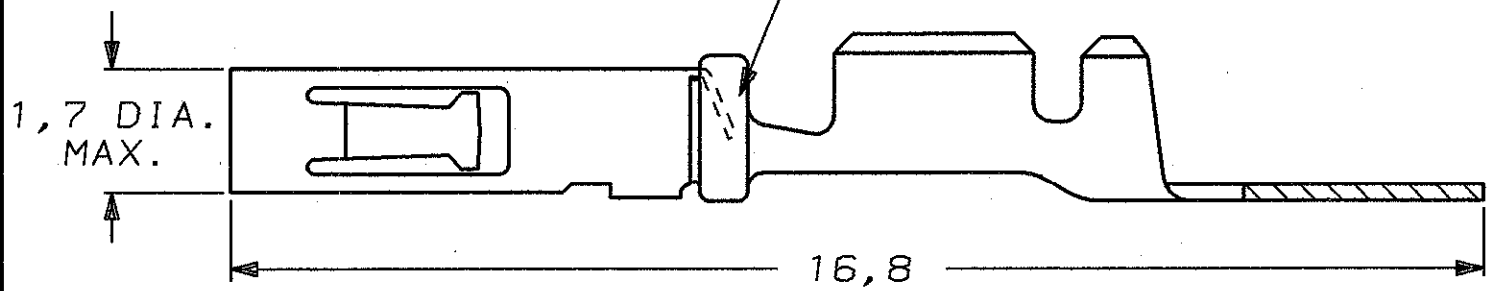
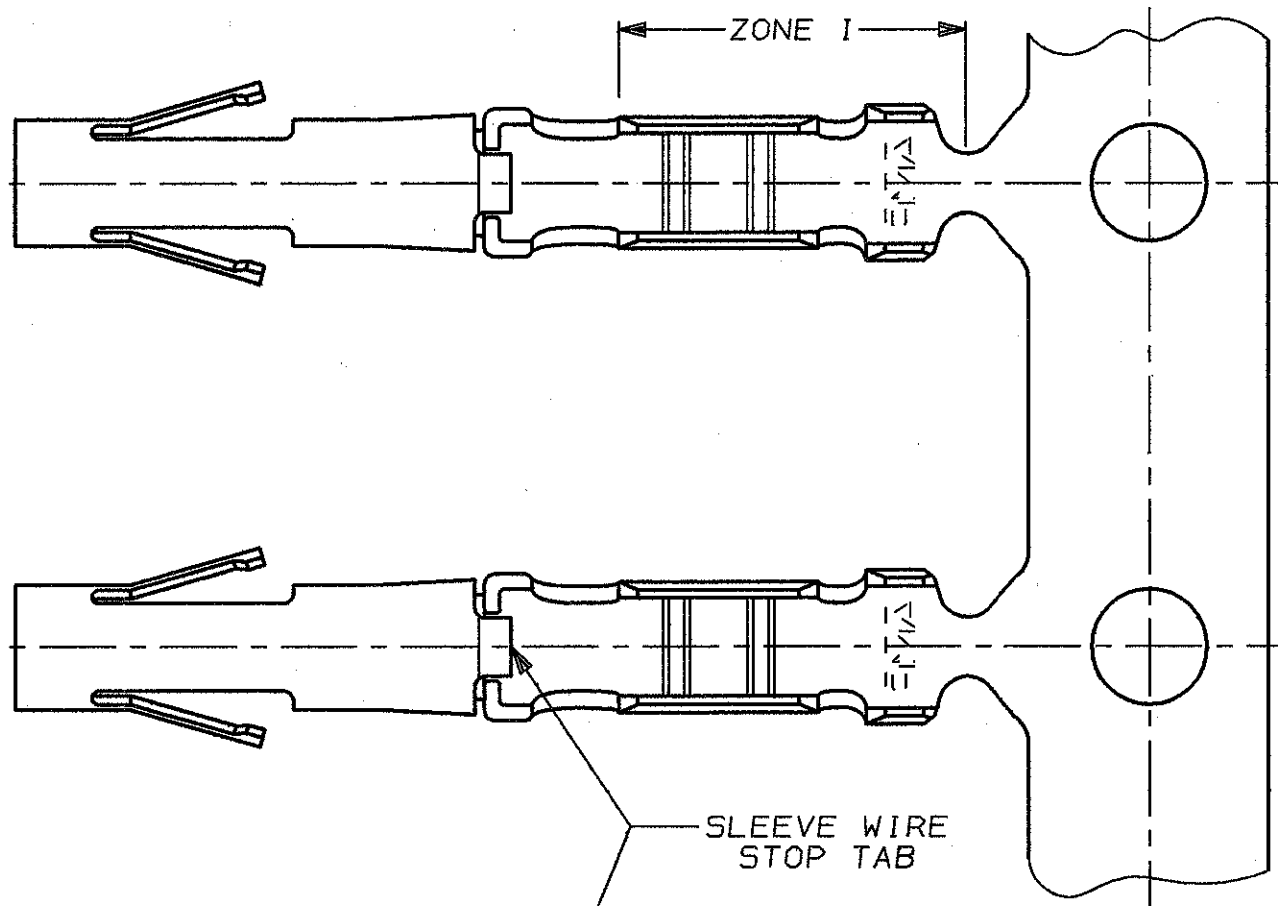

WIRE RANGE :
20-24 AWG 0,2-0,56 mm²
INSULATION RANGE :
1,57 DIA. MAX.

SEE NOTE 5	STAINLESS STEEL	BRASS	1-164153-0	1
POST TINPLATED			164153-9	2
SEE NOTE 6			164153-8	2
SEE NOTE 4			164153-7	2
SEE NOTE 4			164153-6	1
PRETINNED			164153-5	2
PRETINNED			164153-4	1
POST TINPLATED			164153-2	1
SEE NOTE 6			164153-1	1
PLATING OF BODY			MATERIAL OF SLEEVE	MATERIAL OF BODY

-				CUSTOMER DRAWING		FOR REFERENCE ONLY WILL NOT BE UPDATED	
-				© COPYRIGHT 19- BY AMP HOLLAND B.V. ALL INTERNATIONAL RIGHTS RESERVED. AMP PRODUCTS MAY BE COVERED BY U.S. AND FOREIGN AND/OR PATENTS PENDING.			
-				THIS DRAWING IS UNPUBLISHED RELEASED FOR PUBLICATION , 19			
-				AMP AMP HOLLAND B.V. s-Hertogenbosch, The Netherlands.			
-				NAME			
J	EH-0077-92	JvL	CvT	04-03-94	HDR SOCKET CONTACT TYPE XI (CRIMP SNAP-IN)		
LTR.	REVISION RECORD	DR.	CHK.	DATE			
DR.:	J.v.LIEMPT	CHK.:	C.v.TILBURG	APP.:	A.v.SOEST	DWG.No.	
DATE:	6 JAN 1993	DATE:	08-02-93	DATE:	08-02-93	C-164153	REV.LTR.
						J	SHEET
						1 OF 1	A3