



Chipsmall Limited consists of a professional team with an average of over 10 year of expertise in the distribution of electronic components. Based in Hongkong, we have already established firm and mutual-benefit business relationships with customers from,Europe,America and south Asia,supplying obsolete and hard-to-find components to meet their specific needs.

With the principle of "Quality Parts,Customers Priority,Honest Operation,and Considerate Service",our business mainly focus on the distribution of electronic components. Line cards we deal with include Microchip,ALPS,ROHM,Xilinx,Pulse,ON,Everlight and Freescale. Main products comprise IC,Modules,Potentiometer,IC Socket,Relay,Connector.Our parts cover such applications as commercial,industrial, and automotives areas.

We are looking forward to setting up business relationship with you and hope to provide you with the best service and solution. Let us make a better world for our industry!



## Contact us

Tel: +86-755-8981 8866 Fax: +86-755-8427 6832

Email & Skype: info@chipsmall.com Web: www.chipsmall.com

Address: A1208, Overseas Decoration Building, #122 Zhenhua RD., Futian, Shenzhen, China



LOC		DIST		REVISIONS			
P	LTR	DESCRIPTION	DATE	DMN	APVD		
A		INITIAL RELEASE	29MAR11	RC	CW		

### CONNECTOR ASSEMBLY EXAMPLARY LOADED 8

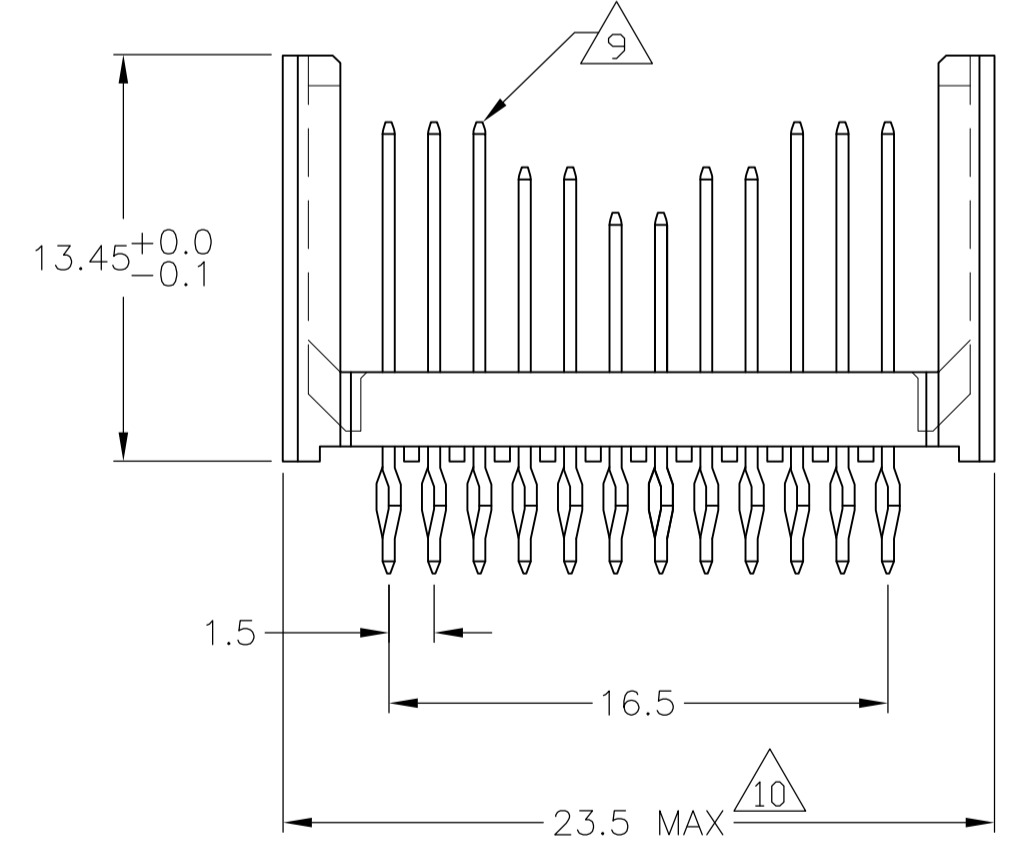
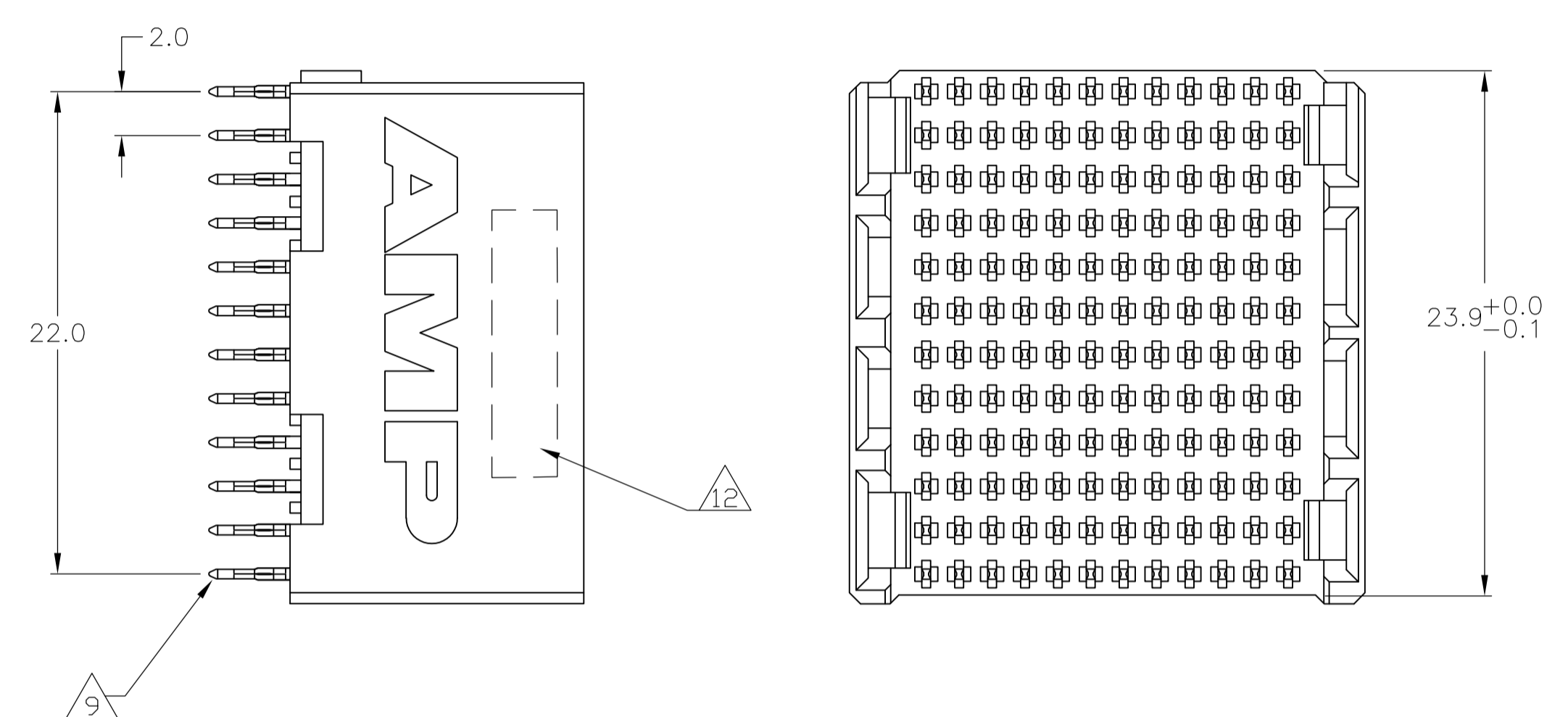

### CONTACT DIMENSIONS SCALE 5:1

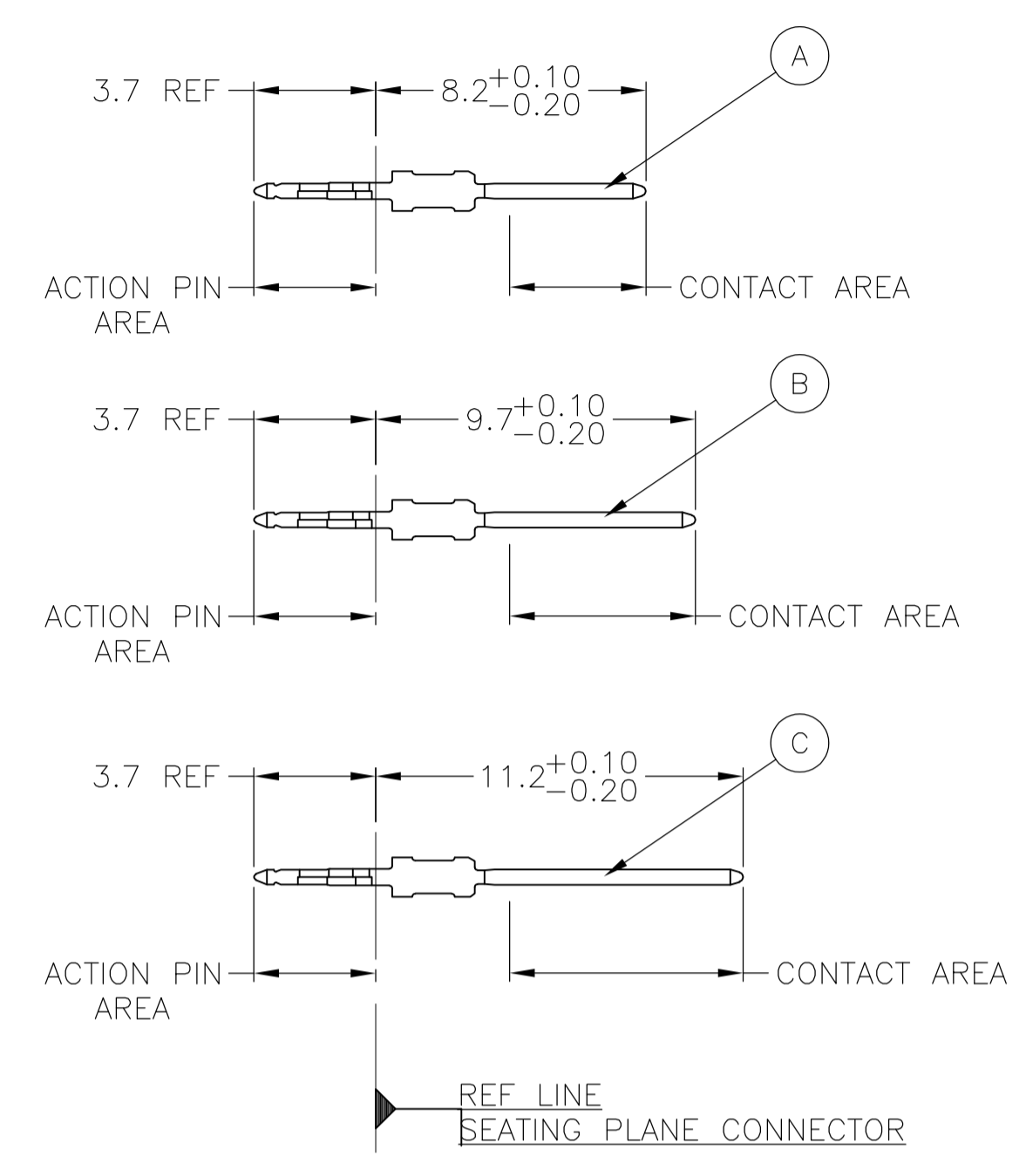

### CONTACT LAYOUT

	a	b	c	d	e	f	g	h	i	j	k	l
1	C	C	C	B	B	A	A	B	B	C	C	C
2	C	C	C	B	B	A	A	B	B	C	C	C
3	C	C	C	B	B	A	A	B	B	C	C	C
4	C	C	C	B	B	A	A	B	B	C	C	C
5	C	C	C	B	B	A	A	B	B	C	C	C
6	C	C	C	B	B	A	A	B	B	C	C	C
7	C	C	C	B	B	A	A	B	B	C	C	C
8	C	C	C	B	B	A	A	B	B	C	C	C
9	C	C	C	B	B	A	A	B	B	C	C	C
10	C	C	C	B	B	A	A	B	B	C	C	C
11	C	C	C	B	B	A	A	B	B	C	C	C
12	C	C	C	B	B	A	A	B	B	C	C	C

### RECOMMENDED PCB-HOLE LAYOUT COMPONENT SIDE SHOWN

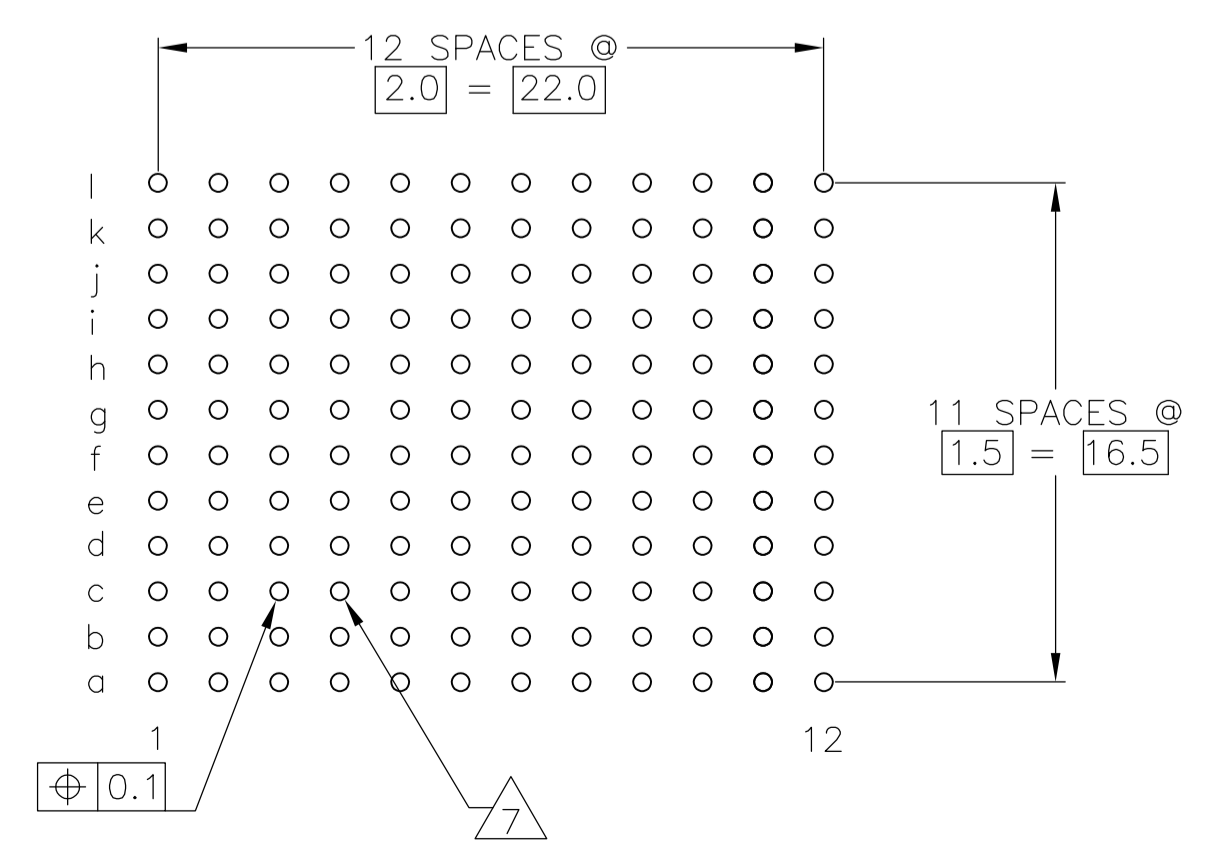

### PLATED THRU HOLES PARAMETERS REFERENCE APPLICATION SPECIFICATION

<span style="border: 1px solid black; padding: 2px;">2/3</span>	1645560-1
FINISH	PART NUMBER

THIS DRAWING IS A CONTROLLED DOCUMENT.		DIN RAYMOND CAO 29MAR11	1645560-1	
DIMENSIONS: mm		CHK SANDERS YAN 29MAR11	NAME	
TOLERANCES UNLESS OTHERWISE SPECIFIED:		APVD MANQIAN WANG 29MAR11	PRODUCT SPEC	
0-PLC ±		108-1738		
1-PLC ± 0.1		APPLICATION SPEC		
2-PLC ±		114-1132		
3-PLC ±		WEIGHT		
4-PLC ±		A1 00779 C=1645560		
ANGLES		CUSTOMER DRAWING		
MATERIAL		SCALE 4:1 SHEET 1 OF 2 REV A		
FINISH SEE TABLE		RESTRICTED TO		

LOC		DIST		REVISIONS				
P	LTR	DESCRIPTION	DATE	DN	APVD			
-	-	SEE SHEET 1	-	-	-			

- 1 MATERIAL:  
CONTACT: PHOSPHOR BRONZE.  
HOUSING: GLASS-FILLED POLYESTER.
- 2 GENERAL PLATING SPECIFICATION: UNDERPLATING  
(ENTIRE CONTACT): 1.27µm MIN NICKEL AND ACTION  
PIN: 0.5µm MIN TIN.  
FOR PLATING OF MATING SURFACES SEE APPLICABLE  
SPECIFICATION REFERENCE FOR EACH DASH NUMBER.
- 3 CONFORMS TO ALL TESTING ACCORDING TO IEC 61076-4-101  
PERFORMANCE LEVEL 2.
- 4 CONFORMS TO ALL TESTING ACCORDING TO IEC 61076-4-101  
PERFORMANCE LEVEL 1.
- 5 CONNECTOR TESTED AND QUALIFIED AGAINST TELCORDIA GR-1217-CORE QUALITY LEVEL 3,  
CENTRAL OFFICE APPLICATIONS.
- 6 CONNECTOR TESTED AND QUALIFIED AGAINST TELCORDIA GR-1217-CORE QUALITY LEVEL 3,  
UNCONTROLLED ENVIROMENT APPLICATIONS.
- 7 PLATED-THROUGH HOLES AT 2x1.5mm SQUARE GRID  
PATTERN DEFINED BY CONTACT LAYOUT.
- 8 FOR ACTUAL PIN LOADING SEE "CONTACT LAYOUT".
- 9 FOR ACTUAL PIN DIMENSIONS SEE "CONTACT DIMENSIONS".
- 10 TO BE MEASURED AT BOTTOM OF SHROUD.
- 11 CONNECTOR LUBRICATED WITH BELCORE APPROVED LUBRICANT,  
TECHNICAL REFERENCE: TR-NWT-001217 ISSUE 1, SEP 1992.
- 12 CONNECTOR PRINTED WITH PART NUMBER AND DATE CODE,  
LOCATED APPROXIMATELY AS SHOWN.

THIS DRAWING IS A CONTROLLED DOCUMENT.		DIN B CARBO 02JUN05		TE Connectivity	
		GSKIPPER 02JUN05			
DIMENSIONS: mm		TOLERANCES UNLESS OTHERWISE SPECIFIED:		NAME	
		0-PLC ±		108-1738	
		1-PLC ± 0.1		APPLICATION SPEC	
		2-PLC ±		114-1132	
		3-PLC ±		114-1132	
MATERIAL SEE SHEET 1		FINISH SEE SHEET 1		RESTRICTED TO	
		WEIGHT		A1 00779 1645560	
		CUSTOMER DRAWING		SCALE 4:1 SHEET 2 OF 2 REV A	