



Chipsmall Limited consists of a professional team with an average of over 10 year of expertise in the distribution of electronic components. Based in Hongkong, we have already established firm and mutual-benefit business relationships with customers from,Europe,America and south Asia,supplying obsolete and hard-to-find components to meet their specific needs.

With the principle of “Quality Parts,Customers Priority,Honest Operation,and Considerate Service”,our business mainly focus on the distribution of electronic components. Line cards we deal with include Microchip,ALPS,ROHM,Xilinx,Pulse,ON,Everlight and Freescale. Main products comprise IC,Modules,Potentiometer,IC Socket,Relay,Connector.Our parts cover such applications as commercial,industrial, and automotives areas.

We are looking forward to setting up business relationship with you and hope to provide you with the best service and solution. Let us make a better world for our industry!



Contact us

Tel: +86-755-8981 8866 Fax: +86-755-8427 6832

Email & Skype: info@chipsmall.com Web: www.chipsmall.com

Address: A1208, Overseas Decoration Building, #122 Zhenhua RD., Futian, Shenzhen, China



LOC	DIST	REVISIONS			
P	LTR	DESCRIPTION	DATE	DRN	APVD
A		INITIAL RELEASE	10MAY11	RC	CW

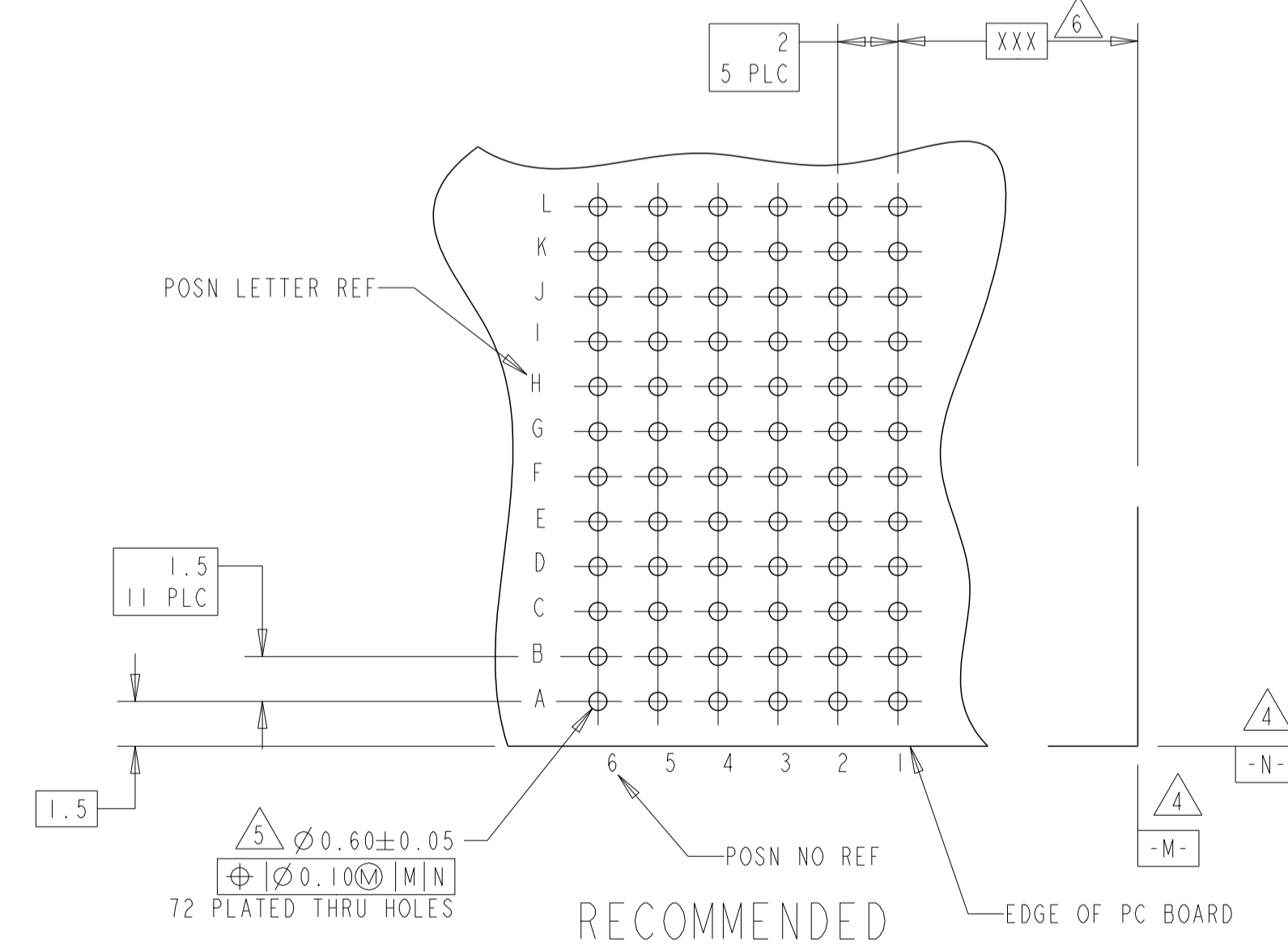
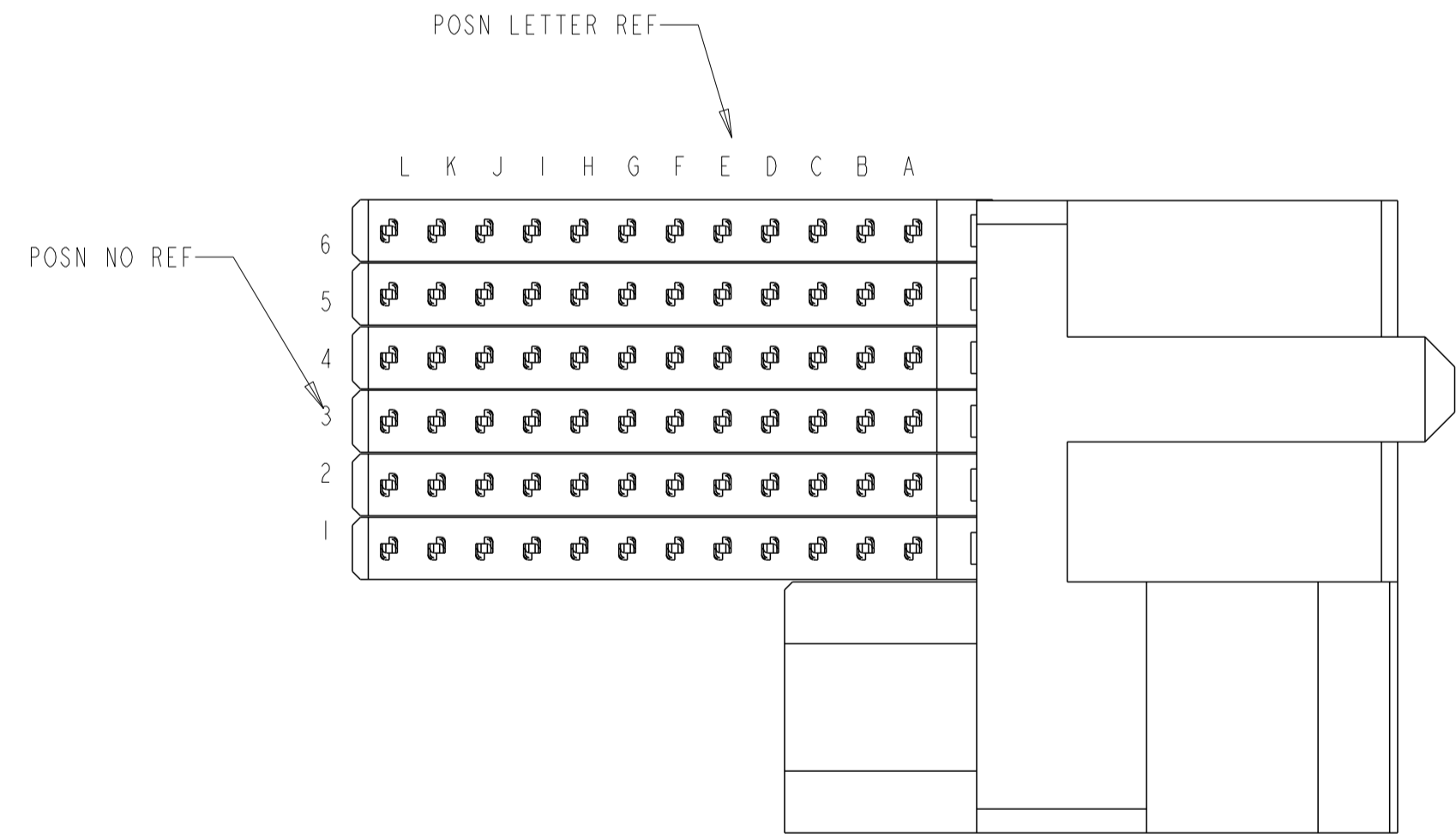
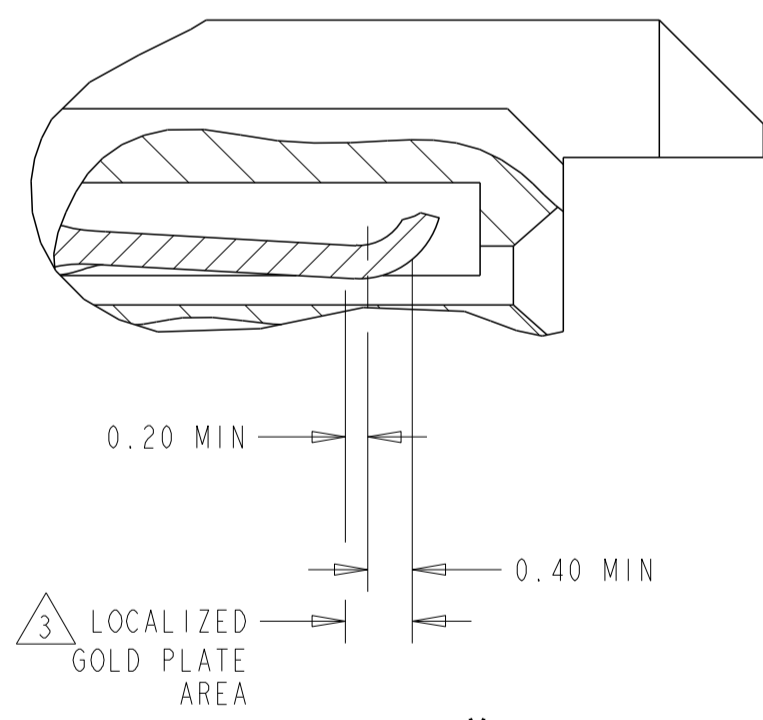
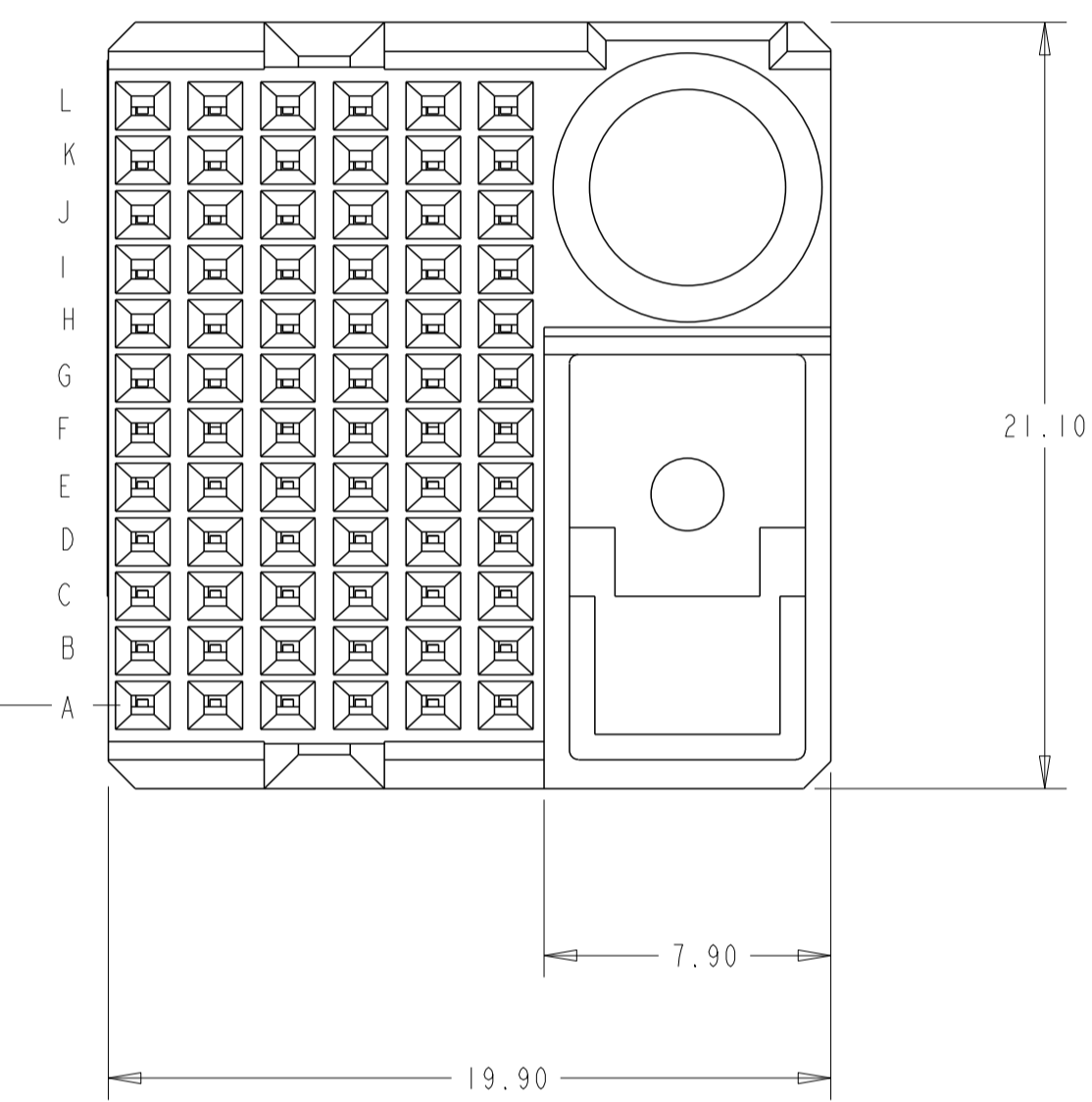
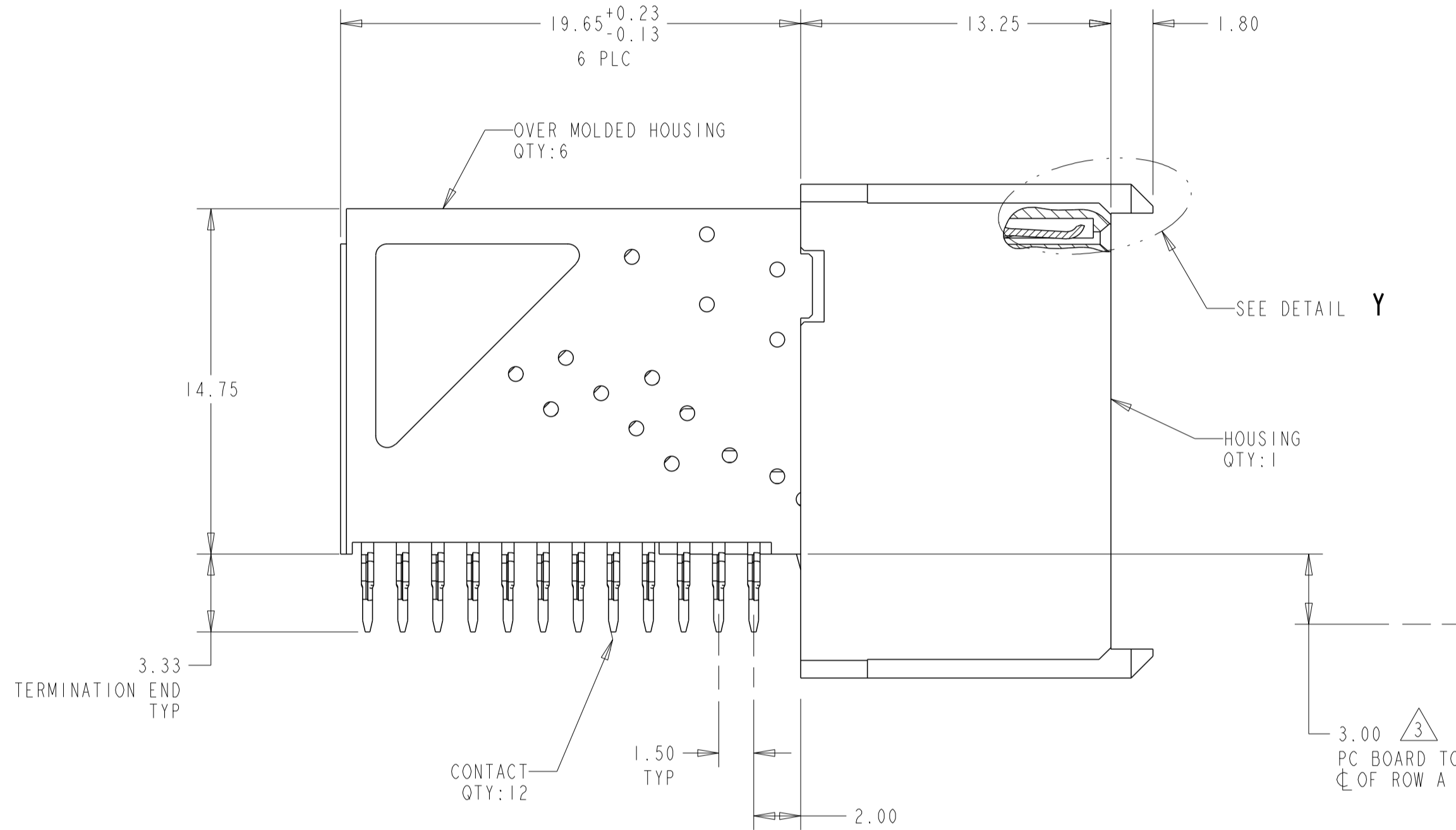
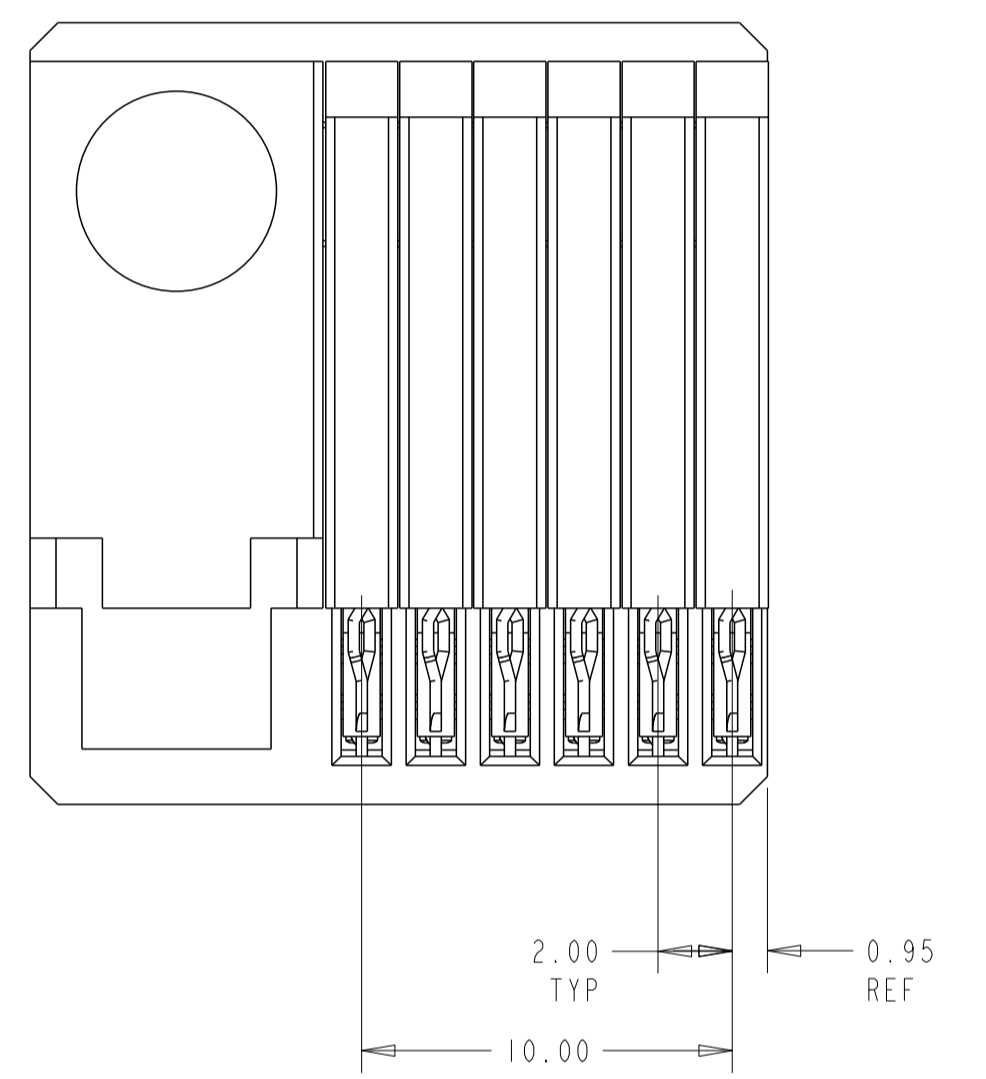
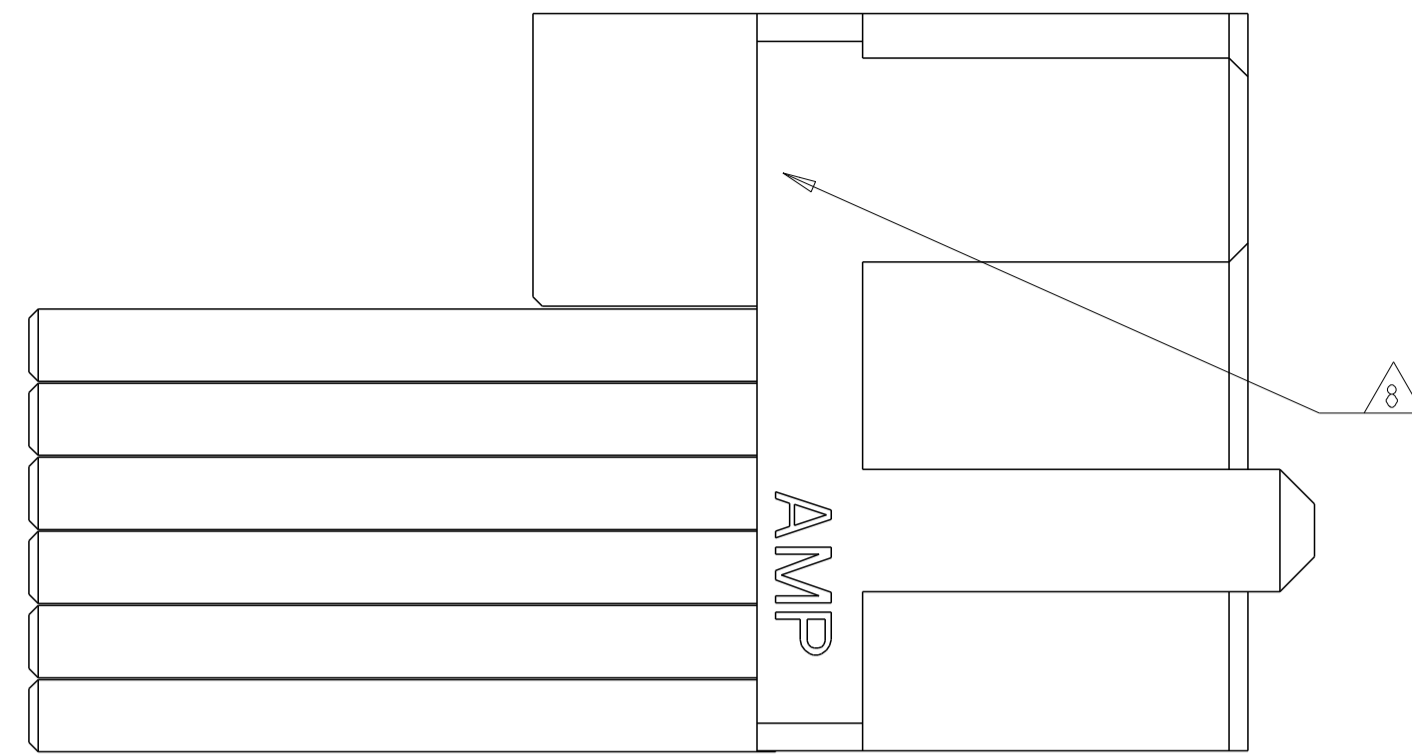

- 1 GLASS FILLED POLYESTER, BLACK
- 2 PHOSPHOR BRONZE
- 3 CONFORMS TO ALL TESTING ACCORDING TO IEC 61076-4-101 PERFORMANCE LEVEL 2.
- 4 DATUMS ESTABLISHED BY CUSTOMER.
- 5 DRILLED HOLE DIAMETER 0.700±0.025
COPPER THK 0.025-0.05
TIN THICKNESS 0.004-0.01
- 6 DIMENSION ESTABLISHED BY CUSTOMER.
- 7 GENERAL PLATING SPECIFICATION: UNDERPLATING (ENTIRE CONTACT): 1.27µm MIN NICKEL AND ACTION PIN: 0.5µm MIN TIN. FOR PLATING OF MATING SURFACES SEE APPLICABLE SPECIFICATION REFERENCE FOR EACH DASH NUMBER
- 8 CONNECTOR PRINTED WITH PART NUMBER AND DATE CODE, LOCATED APPROXIMATELY AS SHOWN.

DETAIL Y
SCALE 15:1
TYPICAL

RECOMMENDED
PRINTED CIRCUIT BOARD
LAYOUT
RECOMMENDED PRINTED CIRCUIT BOARD
COMPONENT SIDE OF PRINTED CIRCUIT BOARD

1645570-1
PART NUMBER

THIS DRAWING IS A CONTROLLED DOCUMENT.		DRN: RAYMOND CAO	TOMAY11	TE Connectivity	
DIMENSIONS: mm		CHK: ALEX SHOAL	TOMAY11	NAME: RECEPTACLE ASSEMBLY, SIGNAL/GROUND COMBINATION, 72 POSITION, RIGHT HAND, Z-PACK 12 HM	
TOLERANCES UNLESS OTHERWISE SPECIFIED:		APVD: MANGHAN WANG	TOMAY11	PRODUCT SPEC	
0 PLC ±0.2		APPLICATION SPEC		SIZE: A1	
1 PLC ±0.2		WEIGHT		CAGE CODE: 00779	
2 PLC ±0.2		RESTRICTED TO		DRAWING NO: 1645570	
3 PLC ±		SCALE: 5:1		SHEET 1 OF 1	
4 PLC ±		REV: A		CUSTOMER DRAWING	
ANGLES: ±					
CONTACTS: 2					
CONTACTS: 3					
CONTACTS: 1					