



Chipsmall Limited consists of a professional team with an average of over 10 year of expertise in the distribution of electronic components. Based in Hongkong, we have already established firm and mutual-benefit business relationships with customers from,Europe,America and south Asia,supplying obsolete and hard-to-find components to meet their specific needs.

With the principle of "Quality Parts,Customers Priority,Honest Operation,and Considerate Service",our business mainly focus on the distribution of electronic components. Line cards we deal with include Microchip,ALPS,ROHM,Xilinx,Pulse,ON,Everlight and Freescale. Main products comprise IC,Modules,Potentiometer,IC Socket,Relay,Connector.Our parts cover such applications as commercial,industrial, and automotives areas.

We are looking forward to setting up business relationship with you and hope to provide you with the best service and solution. Let us make a better world for our industry!



Contact us

Tel: +86-755-8981 8866 Fax: +86-755-8427 6832

Email & Skype: info@chipsmall.com Web: www.chipsmall.com

Address: A1208, Overseas Decoration Building, #122 Zhenhua RD., Futian, Shenzhen, China



CLEAR HOLE MOUNTING BRACKETS

Designers' Choice



BOARD BRACKETS

Originally designed for our line of standardized terminal boards; these brackets can also be used in other applications.

Choice of Steel or Aluminum

MATERIAL:

.062 Steel, Nickel Plate

.062 Aluminum

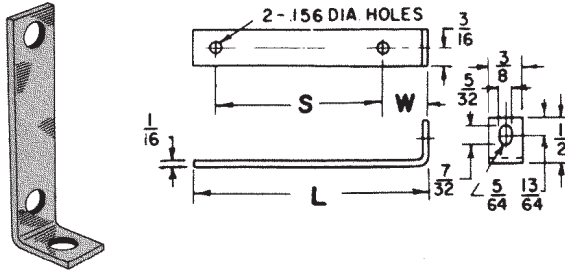

CAT. NO.		W	L	S	For Use With Board No's (see page 98)		
Steel	Alum.				15032	15072	15092
1556	622	3/8	1 5/8	1	15032	15072	15092
1567	623	3/8	2 1/8	1 1/2	15033	15073	15093
1568	624	3/8	2 5/8	2	15034	15074	15094
1569	625	3/8	3 1/8	2 1/2	15035	15075	15095
1570	626	9/32	1 3/16	3/4	15022	15024	15030
1571	627	9/32	1 5/8	1 3/16	15036	15076	15096

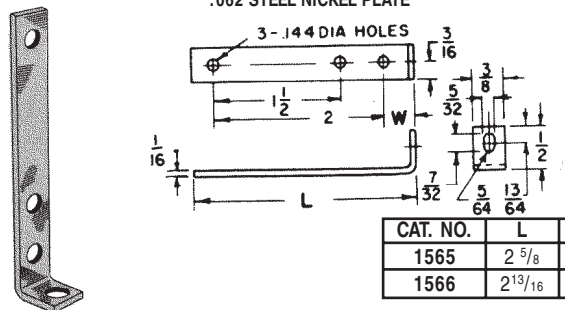

CAT. NO.	L	W
1565	2 5/8	3/8
1566	2 13/16	9/16

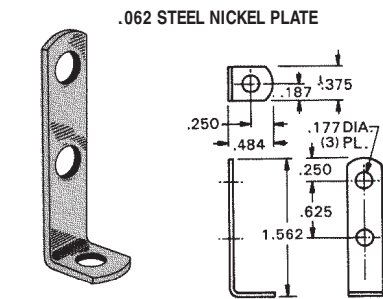

CAT. NO. 1564

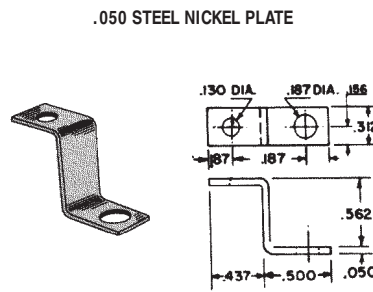

CAT. NO. 4325

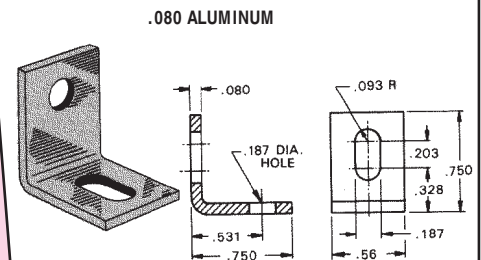

CAT. NO. 4337

BOARD SUPPORT BRACKETS

MATERIAL: Brass, Zinc Plate

A sturdy support for mounting of standardized terminal boards.

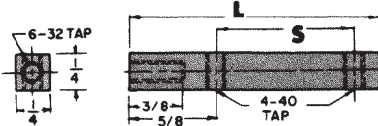

CAT. NO.	Overall Length "L"	Spacing "S"
1647	2 3/8	1 1/2
1648	2 7/8	2
1649	3 3/8	2 1/2

UNIVERSAL BRACKETS

A wide variety of brackets for various mounting applications.

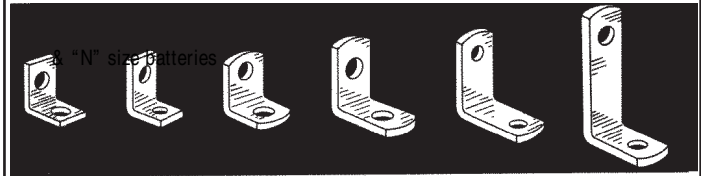

633	613	615	618	619	620
			4335 4336		4326

STANDARD BRACKETS
(Brass and Steel)

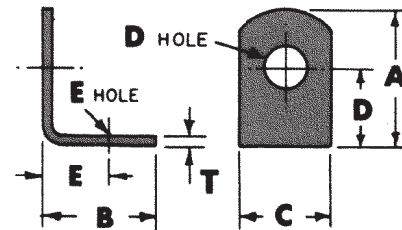

Selection of Brackets with Clear Holes

CAT. NO.	A	B	C	D	"D" Hole Dia.	"E" Hole Dia.	"T" Material	Finish
633	.375	.375	.281	.218	.140	.218	.140	.032 Brass Nickel
613	.390	.453	.375	.234	.147	.299	.128	.032 Brass Nickel
615	.420	.343	.281	.281	.144	.203	.128	.032 Brass Tin
4335	.562	.562	.500	.412	.120	.411	.120	.062 Steel Nickel
4336	.562	.562	.500	.412	.144	.412	.144	.062 Steel Nickel
618	.628	.628	.375	.378	.169	.378	.169	.050 Brass Tin
619	.687	.687	.375	.500	.144	.500	.144	.032 Steel Tin
4326	1.013	.487	.312	.816	.140	.332	.140	.050 Steel Nickel
620	1.156	.656	.375	.906	.169	.420	.169	.032 Steel Tin

CUSTOM STAMPING AND ASSEMBLY

Keystone is fully integrated to meet your total design & production needs.

Manufacturing custom designs & modifications of standard items is our specialty.

Quotations on special stamping & assembly furnished promptly upon receipt of sample, sketch, print or CAD drawings.