



Chipsmall Limited consists of a professional team with an average of over 10 year of expertise in the distribution of electronic components. Based in Hongkong, we have already established firm and mutual-benefit business relationships with customers from,Europe,America and south Asia,supplying obsolete and hard-to-find components to meet their specific needs.

With the principle of “Quality Parts,Customers Priority,Honest Operation,and Considerate Service”,our business mainly focus on the distribution of electronic components. Line cards we deal with include Microchip,ALPS,ROHM,Xilinx,Pulse,ON,Everlight and Freescale. Main products comprise IC,Modules,Potentiometer,IC Socket,Relay,Connector.Our parts cover such applications as commercial,industrial, and automotives areas.

We are looking forward to setting up business relationship with you and hope to provide you with the best service and solution. Let us make a better world for our industry!



## Contact us

Tel: +86-755-8981 8866 Fax: +86-755-8427 6832

Email & Skype: info@chipsmall.com Web: www.chipsmall.com

Address: A1208, Overseas Decoration Building, #122 Zhenhua RD., Futian, Shenzhen, China



- A. Material is .018" (0.46mm) thick, red static dissipative vinyl. Surface resistance on both sides is 10E6 - 10E8 ohms, per ANSI/ESD S4.1
- B. Two ground points, 10mm (.395") female sockets, riveted to material.
- C. Common point ground cord, with 1 megohm resistor, 15' long high flex 20 AWG wire with black PVC .107" O.D. insulation. Ground terminations are 10mm (.395") male snap with two un-resisted banana jacks for grounding wrist straps.
- D. A large detachable screw-on grounding clip (item 09750) is included to connect to a ground point. The large, insulated clip provides plenty of holding power.
- E. Molded, 10-32 threaded metal end can fit into ground socket on 3-wire AC electrical outlet.
- F. Item 16475 includes one adjustable elastic wrist band and one six foot coil cord with a 1 megohm resistor. (See Drawings 14810 and 14010, respectively.)
- G. Canvas field service carrying case included.

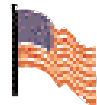
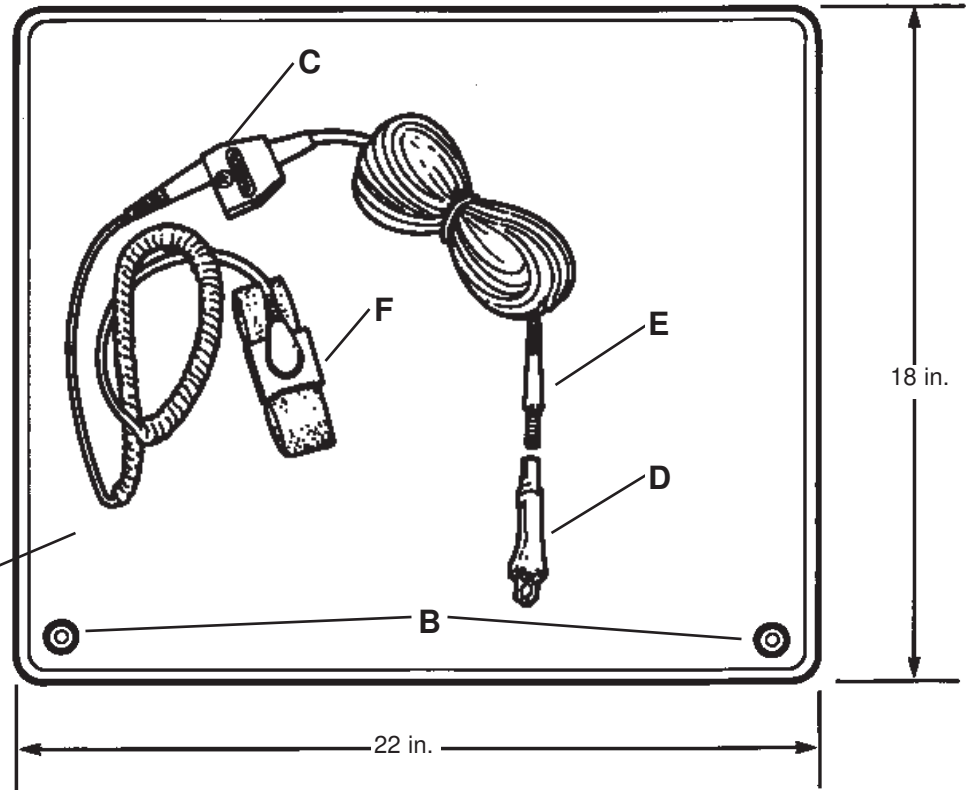

Made in America

**Specifications:**

Color	Red
Thickness	0.018" (0.46mm)
Bursting Strength	400 PSI

**Electrical Properties:**

RTT(Point to Point)	10E6 - 10E8 Ohms	per ANSI/ESD-S4.1
Charge Decay	0.01 Sec. 5000V to 0V 12% RH	per FTMS 101C-4046.1

Dissipative worksurface slows charge removal; meets ANSI/ESD S20.20 worksurface required limit and recommendation of ANSI/ESD S4.1

For complete information on field service kits, ask for Technical Bulletin TB-2011.

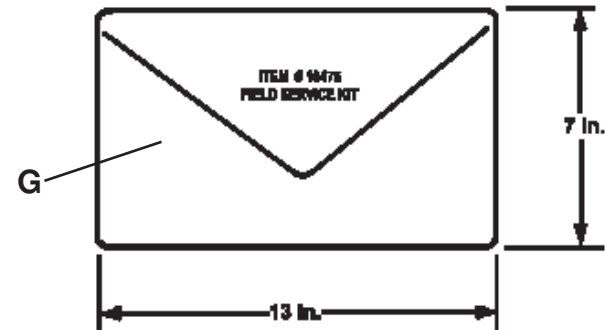

**KIT, FIELD SERVICE, VINYL, 18" x 22", RED**

**DESCO**

DESCO WEST: 3651 WALNUT AVE., CHINO, CA 91710 WEB SITE: www.desco.com  
 PHONE (909) 627-8178 FAX (909) 627-7449  
 DESCO EAST: 90 HUDSON RD, CANTON, MA 02021-1407  
 PHONE (781) 821-8370 FAX (781) 575-0172

**DRAWING NUMBER**  
16475

**DATE:**  
July 2008