



Chipsmall Limited consists of a professional team with an average of over 10 year of expertise in the distribution of electronic components. Based in Hongkong, we have already established firm and mutual-benefit business relationships with customers from,Europe,America and south Asia,supplying obsolete and hard-to-find components to meet their specific needs.

With the principle of “Quality Parts,Customers Priority,Honest Operation,and Considerate Service”,our business mainly focus on the distribution of electronic components. Line cards we deal with include Microchip,ALPS,ROHM,Xilinx,Pulse,ON,Everlight and Freescale. Main products comprise IC,Modules,Potentiometer,IC Socket,Relay,Connector.Our parts cover such applications as commercial,industrial, and automotives areas.

We are looking forward to setting up business relationship with you and hope to provide you with the best service and solution. Let us make a better world for our industry!



Contact us

Tel: +86-755-8981 8866 Fax: +86-755-8427 6832

Email & Skype: info@chipsmall.com Web: www.chipsmall.com

Address: A1208, Overseas Decoration Building, #122 Zhenhua RD., Futian, Shenzhen, China



4

3

2

1

This drawing involves proprietary design rights of Tyco Electronics Corporation, and all design, manufacture, reproduction, use and sale rights regarding the same are expressly reserved. It is submitted for a specific purpose and the recipient by accepting this drawing, assumes custody and control and agrees to take reasonable precautions: (a) that this drawing will not be copied and reproduced, in whole or in part, or its contents revealed in any manner, or to any person except to meet the purpose for which it was delivered and (b) that any special features peculiar to this design will not be incorporated in other projects without the expressed written permission of Tyco Electronics Corporation.

| REVISIONS | | | |
|-----------|-----|-------------------------------------|----------|
| EC | REV | DESCRIPTION | DATE |
| CPR | A | NEW RELEASE, PREVIOUSLY CUD 499-070 | 03/21/06 |

- 8. REFERENCE ELCON PART NUMBER 235-0165-01100.
- 7. SEE DRAWING C-1648134 FOR MATING PIN CONNECTOR.
- 6. ITEMS PROVIDED TO THIS SPECIFICATION TO BE PERMANENTLY IDENTIFIED PER THE FOLLOWING IDENTIFIER: WEEK

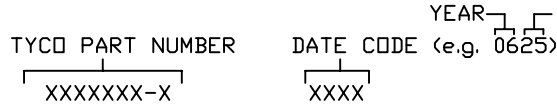

- 5. ALL DIMENSIONS SHOWN ACROSS A CENTERLINE (C) SHALL BE CENTRALIZED WITHIN THE TOLERANCE INDICATED FOR THAT DIMENSION.
- 4. A REFERENCE DIMENSION (.XXX) IS WITHOUT TOLERANCE AND USED FOR INFORMATION PURPOSE ONLY.
- 3. RECOMMENDED MOUNTING HARDWARE: TO BE ORDERED SEPARATELY.
 - FOR PANEL MOUNTING, USE
 - 1650402-1: SHOULDER SCREW, #8-32
 - 1650589-1: SHOULDER SCREW, M4X0.7
 - FOR PCB MOUNTING, USE COMMERCIALY AVAILABLE SCREW AND WASHER (IF REQUIRED).

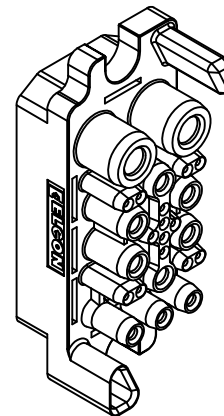

- 2. MATERIALS:
 - HOUSING: THERMOPLASTIC, GLASS REINFORCED, COLOR-BLACK UL94V-0 FLAMMABILITY RATED.
 - RETENTION CLIP: COPPER ALLOY OR STAINLESS STEEL
- 1. PART NUMBER CHANGES AND OR DESIGN CHANGES AFFECTING ITEM INTERCHANGEABILITY REQUIRE PRIOR ELCON APPROVAL AND AUTHORIZATION BY REVISION TO THIS DRAWING.

NOTES: UNLESS OTHERWISE SPECIFIED

| | |
|-------------|-------------|
| 1648135-1 | AS SHOWN |
| PART NUMBER | DESCRIPTION |

| | | | |
|--|------------------------------|------------------|---|
| INCH OR INCH (MM) THIRD ANGLE PROJECTION UNLESS OTHERWISE SPECIFIED DIMENSIONS ARE IN INCHES (METRIC) TOLERANCES ANGLES ± .5° DECIMALS .XXX ± .010 (.25) .XX ± .02 (.5) | DRAWN HA NGUYEN | DATE 03/21/06 | tyco Tyco Electronics Corporation Electronics Menlo Park, Ca 94025 ELCON TITLE CONNECTOR, SOCKET HOUSING SIZE 2X#4, 14X#20, 6X#8, 3X#12 200A MIDDLE DRAWER SIZE DWG NUMBER B C = 1648135 REV. A |
| | CHECKED | | |
| | APPROVED | | |
| | APPROVED STEVE FLICKINGER | 03/21/06 | |
| | DCA APPROVED HA NGUYEN | 03/21/06 | |
| | ACAD FILE NUMBER | C1648135A.DWG | DWG SCALE 1=1 SH 1 OF 3 |

4

3

2

1

This drawing involves proprietary design rights of Tyco Electronics Corporation, and all design, manufacture, reproduction, use and sale rights regarding the same are expressly reserved. It is submitted for a specific purpose and the recipient by accepting this drawing, assumes custody and control and agrees to take reasonable precautions: (a) that this drawing will not be copied and reproduced, in whole or in part, or its contents revealed in any manner, or to any person except to meet the purpose for which it was delivered and (b) that any special features peculiar to this design will not be incorporated in other projects without the expressed written permission of Tyco Electronics Corporation.

| REVISIONS | | | |
|-----------|-----|-------------|------|
| EC | REV | DESCRIPTION | DATE |
| | | SEE SHEET 1 | |

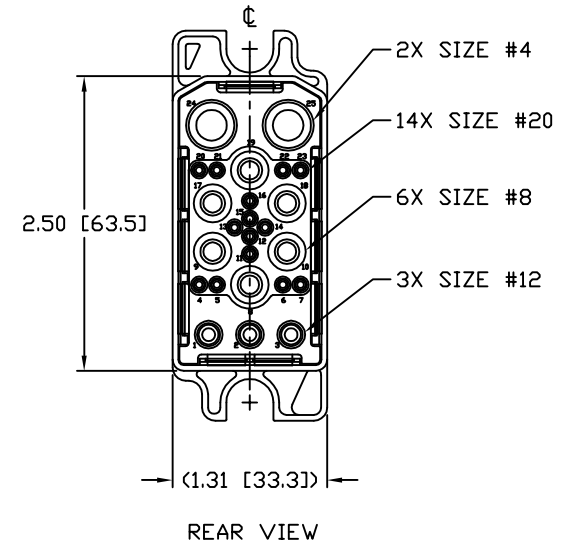
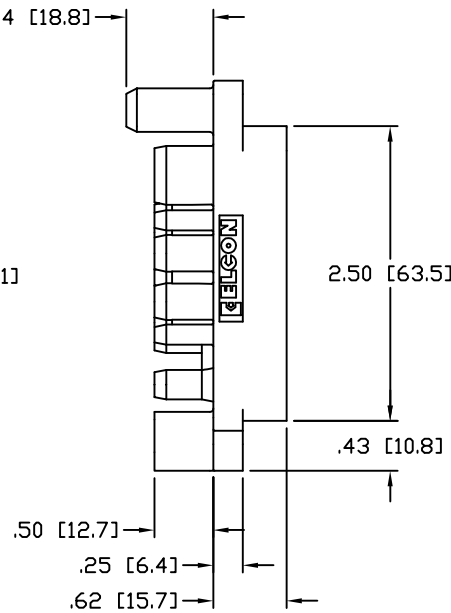
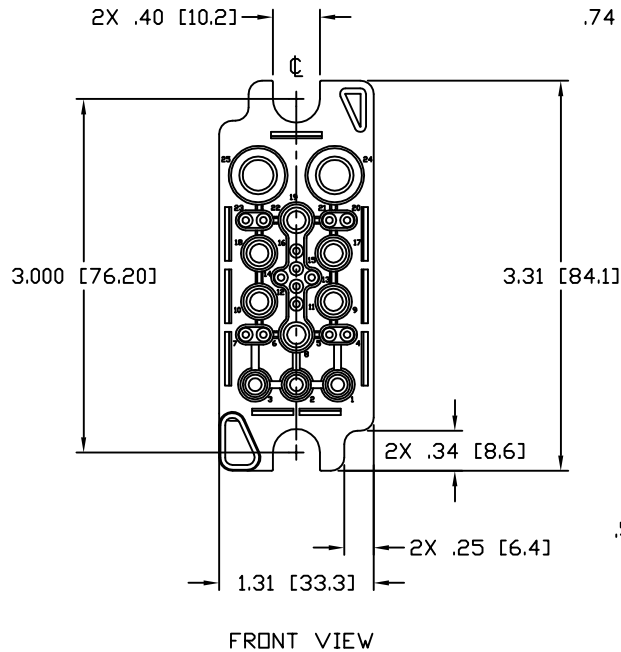

| | | | |
|--|------------------|---------------|---|
| INCH OR INCH (MM) THIRD ANGLE PROJECTION UNLESS OTHERWISE SPECIFIED DIMENSIONS ARE IN INCHES (METRIC) TOLERANCES ANGLES ± .5° DECIMALS .XXX ± .010 (.25) .XX ± .02 (.3) | DRAWN | DATE | Tyco Electronics Corporation Menlo Park, Ca 94025 |
| | HA NGUYEN | 03/21/06 | |
| | CHECKED | | |
| | APPROVED | | |
| | APPROVED | | TITLE |
| | STEVE FLICKINGER | 03/21/06 | CONNECTOR, SOCKET HOUSING SIZE 2X#4, 14X#20, 6X#8, 3X#12 200A MIDDLE DRAWER |
| | DCA APPROVED | | SIZE DWG NUMBER |
| | HA NGUYEN | 03/21/06 | B C = 1648135 |
| | ACAD FILE NUMBER | C1648135A.DWG | REV. A |
| | | | DWG SCALE 1=1 SH 2 OF 3 |

This drawing involves proprietary design rights of Tyco Electronics Corporation, and all design, manufacture, reproduction, use and sale rights regarding the same are expressly reserved. It is submitted for a specific purpose and the recipient by accepting this drawing, assumes custody and control and agrees to take reasonable precautions: (a) that this drawing will not be copied and reproduced, in whole or in part, or its contents revealed in any manner, or to any person except to meet the purpose for which it was delivered and (b) that any special features peculiar to this design will not be incorporated in other projects without the expressed written permission of Tyco Electronics Corporation.

| REVISIONS | | | |
|-----------|-----|-------------|------|
| EC | REV | DESCRIPTION | DATE |
| | | SEE SHEET 1 | |

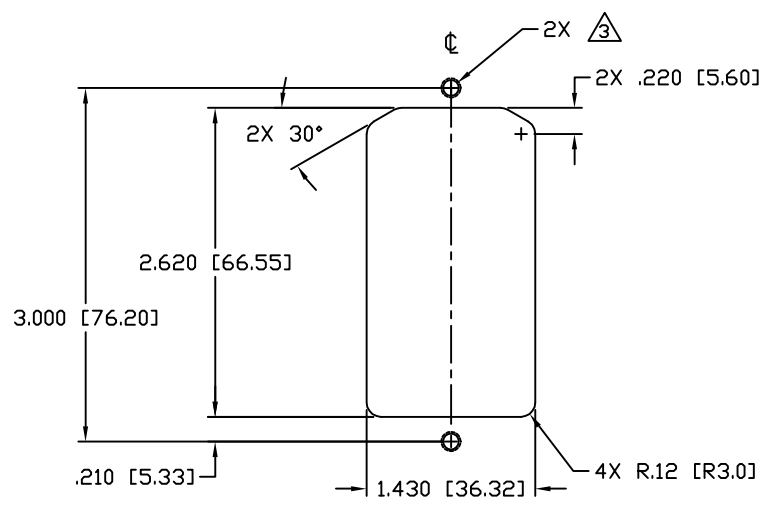

RECOMMENDED PANEL CUTOUT AS VIEWED FROM CONNECTOR MOUNTING SIDE (FRONT VIEW)

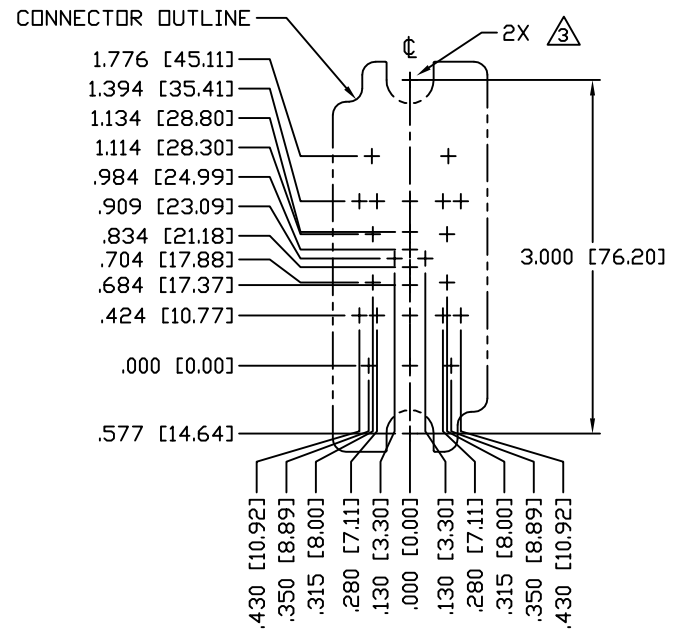

RECOMMENDED CONTACT LAYOUT AS VIEWED FROM CONNECTOR MOUNTING SIDE (FRONT VIEW)

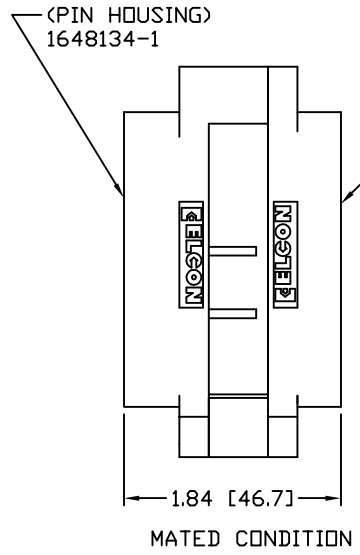

MATED CONDITION

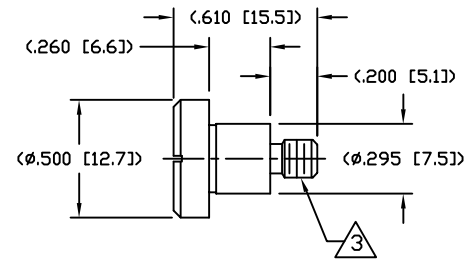

SHOULDER SCREW SCALE 2:1 SHOWN FOR REFERENCE ONLY

| | | | | | |
|--|------------------|---------------|--|-------------|-----------|
| INCH OR INCH (MM) THIRD ANGLE PROJECTION UNLESS OTHERWISE SPECIFIED DIMENSIONS ARE IN INCHES (METRIC) TOLERANCES ANGLES ± .5° DECIMALS .XXX ± .010 (.25) .XX ± .02 (.5) | DRAWN | DATE | Tyco Electronics Corporation Menlo Park, Ca 94025 | | |
| | HA NGUYEN | 03/21/06 | TITLE | | |
| | CHECKED | | USER INFORMATION RECOMMENDED PANEL CUTOUT CONTACT LAYOUT & MATED CONDITION | | |
| | APPROVED | | SIZE | DWG NUMBER | REV. |
| | STEVE FLICKINGER | 03/21/06 | B | C = 1648135 | A |
| | DCA APPROVED | | | | |
| | HA NGUYEN | 03/21/06 | | | |
| | ACAD FILE NUMBER | C1648135A.DWG | DWG SCALE | 1=1 | SH 3 OF 3 |