



Chipsmall Limited consists of a professional team with an average of over 10 year of expertise in the distribution of electronic components. Based in Hongkong, we have already established firm and mutual-benefit business relationships with customers from,Europe,America and south Asia,supplying obsolete and hard-to-find components to meet their specific needs.

With the principle of “Quality Parts,Customers Priority,Honest Operation,and Considerate Service”,our business mainly focus on the distribution of electronic components. Line cards we deal with include Microchip,ALPS,ROHM,Xilinx,Pulse,ON,Everlight and Freescale. Main products comprise IC,Modules,Potentiometer,IC Socket,Relay,Connector.Our parts cover such applications as commercial,industrial, and automotives areas.

We are looking forward to setting up business relationship with you and hope to provide you with the best service and solution. Let us make a better world for our industry!



Contact us

Tel: +86-755-8981 8866 Fax: +86-755-8427 6832

Email & Skype: info@chipsmall.com Web: www.chipsmall.com

Address: A1208, Overseas Decoration Building, #122 Zhenhua RD., Futian, Shenzhen, China



This drawing involves proprietary design rights of Tyco Electronics Corporation, and all design, manufacture, reproduction, use and sale rights regarding the same are expressly reserved. It is submitted for a specific purpose and the recipient by accepting this drawing, assumes custody and control and agrees to take reasonable precautions; (a) that this drawing will not be copied and reproduced, in whole or in part, or its contents revealed in any manner, or to any person except to meet the purpose for which it was delivered and (b) that any special features peculiar to this design will not be incorporated in other projects without the expressed written permission of Tyco Electronics Corporation.

REVISIONS			
EC	REV	DESCRIPTION	DATE
CPR	A	NEW RELEASE	3/22/06

- 7. CONTACTS PURCHASED SEPARATELY.
- 6. ELCON EQUIVALENT SERIES 296-0040-01100.
- 5. ITEMS PROVIDED TO THIS SPECIFICATION TO BE PERMANENTLY IDENTIFIED PER THE FOLLOWING IDENTIFIER:

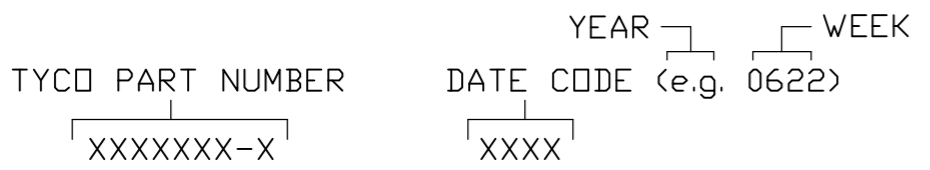

4. A REFERENCE DIMENSION (X.XX) IS WITHOUT TOLERANCE AND USED FOR INFORMATION ONLY.

3. FINISHES:
RETENTION CLIPS: BRITE DIP PICKLED PER INDUSTRY STANDARDS.

2. MATERIALS:
INSULATORS: THERMOPLASTIC, GLASS REINFORCED, UL94V-0 FLAMMABILITY RATED, COLOR-BLACK.

RETENTION CLIPS: COPPER OR STAINLESS STEEL.

1. PART NUMBER CHANGES AND OR DESIGN CHANGES AFFECTING ITEM INTERCHANGEABILITY REQUIRE PRIOR TYCO APPROVAL AND AUTHORIZATION BY REVISION TO THIS DRAWING.

NOTES: UNLESS OTHERWISE SPECIFIED

TYCO PART NUMBER
1648574-1

<p>THIRD ANGLE PROJECTION</p> <p>UNLESS OTHERWISE SPECIFIED DIMENSIONS ARE IN INCHES (METRIC)</p> <p>TOLERANCES</p> <p>ANGLES ± .5°</p> <p>DECIMALS</p> <p>.XXX ± .010 (.25)</p> <p>.XX ± .02 (.3)</p>	<p>INCH OR INCH (MM)</p> <p>← INCH →</p>	<p>DRAWN</p> <p>R. F. A.</p>	<p>DATE</p> <p>3/22/06</p>	<p>tyco Tyco Electronics Corporation ELCON</p> <p>Electronics Menlo Park, Ca 94025</p>		
	<p>CHECKED</p>	<p>TITLE</p> <p>CONNECTOR, SOCKET WITH RETENTION CLIPS QUAD POWER</p>	<p>APPROVED</p>	<p>APPROVED</p> <p>S. FLICKINGER</p>	<p>SIZE</p> <p>B</p>	<p>DWG NUMBER</p> <p>C= 1648574</p>
	<p>APPROVED</p>	<p>REV.</p> <p>A</p>	<p>DCA APPROVED</p>	<p>ACAD FILE NUMBER</p> <p>C1648574A.DWG</p>	<p>DWG SCALE</p> <p>1=1</p>	<p>SH 1 OF 2</p>
	<p>APPROVED</p>					

This drawing involves proprietary design rights of Tyco Electronics Corporation, and all design, manufacture, reproduction, use and sale rights regarding the same are expressly reserved. It is submitted for a specific purpose and the recipient by accepting this drawing, assumes custody and control and agrees to take reasonable precautions; (a) that this drawing will not be copied and reproduced, in whole or in part, or its contents revealed in any manner, or to any person except to meet the purpose for which it was delivered and (b) that any special features peculiar to this design will not be incorporated in other projects without the expressed written permission of Tyco Electronics Corporation.

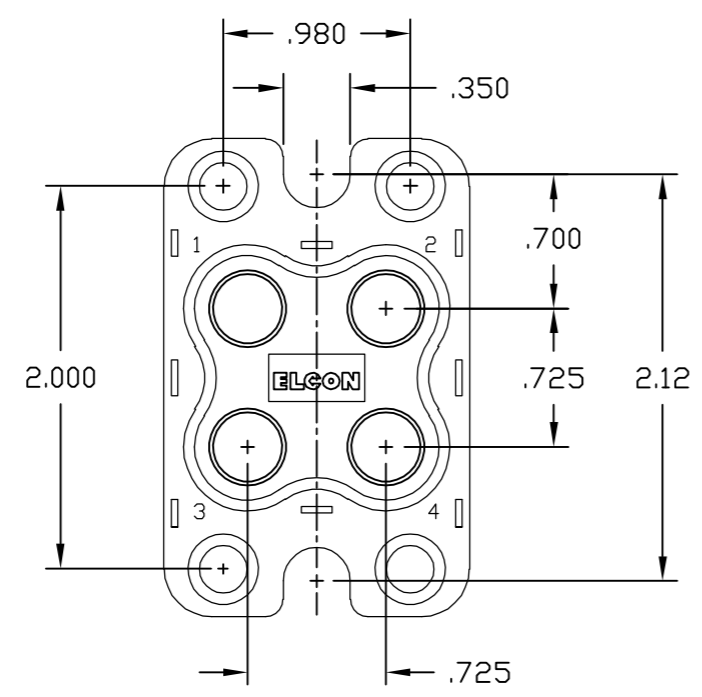

FRONT VIEW

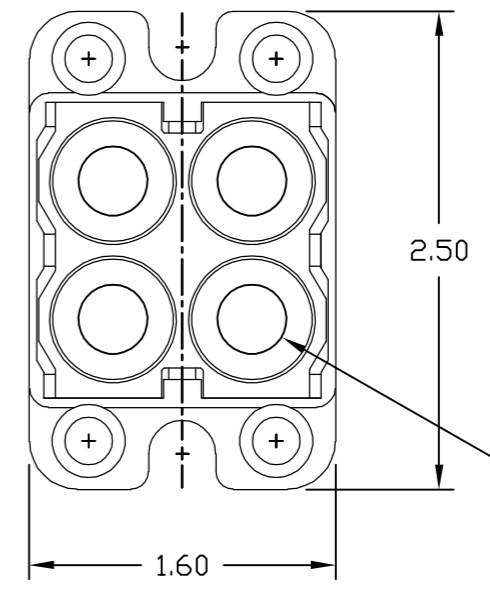
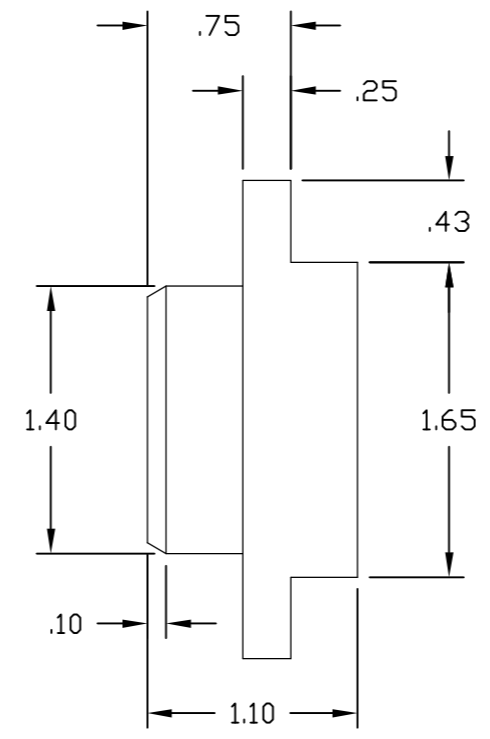

REAR VIEW

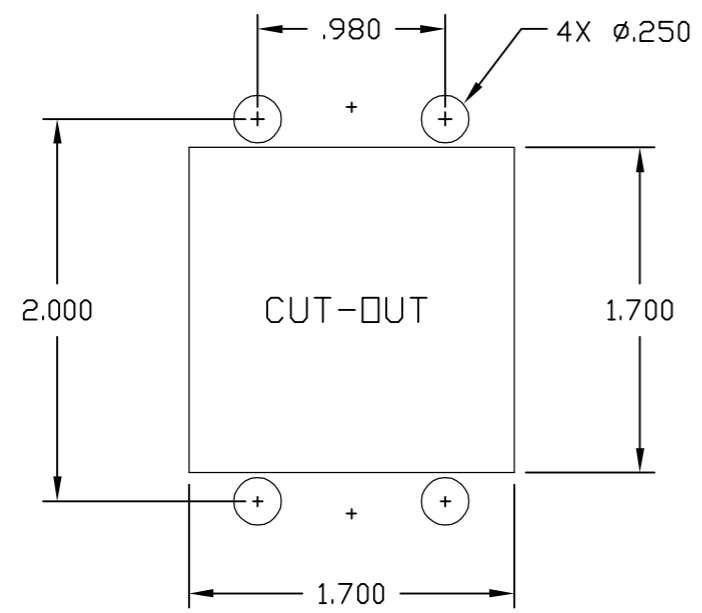

PANEL MOUNT

REVISIONS			
EC	REV	DESCRIPTION	DATE
		SEE SHEET 1	

INCH OR INCH (MM) THIRD ANGLE PROJECTION UNLESS OTHERWISE SPECIFIED DIMENSIONS ARE IN INCHES (METRIC) TOLERANCES ANGLES ± .5' DECIMALS .XXX ± .010 (.25) .XX ± .02 (.3)	DRAWN R. F. A.	DATE 3/22/06	Tyco Electronics Corporation Menlo Park, Ca 94025 	
	CHECKED			TITLE CONNECTOR, SOCKET WITH RETENTION CLIPS QUAD POWER
	APPROVED			SIZE DWG NUMBER REV. B C-1648574 A
	APPROVED S. FLICKINGER			
	DCA APPROVED			
	ACAD FILE NUMBER	C1648574A.DWG	DWG SCALE 1=1 SH 2 OF 2	