



Chipsmall Limited consists of a professional team with an average of over 10 year of expertise in the distribution of electronic components. Based in Hongkong, we have already established firm and mutual-benefit business relationships with customers from,Europe,America and south Asia,supplying obsolete and hard-to-find components to meet their specific needs.

With the principle of “Quality Parts,Customers Priority,Honest Operation,and Considerate Service”,our business mainly focus on the distribution of electronic components. Line cards we deal with include Microchip,ALPS,ROHM,Xilinx,Pulse,ON,Everlight and Freescale. Main products comprise IC,Modules,Potentiometer,IC Socket,Relay,Connector.Our parts cover such applications as commercial,industrial, and automotives areas.

We are looking forward to setting up business relationship with you and hope to provide you with the best service and solution. Let us make a better world for our industry!



## Contact us

Tel: +86-755-8981 8866 Fax: +86-755-8427 6832

Email & Skype: info@chipsmall.com Web: www.chipsmall.com

Address: A1208, Overseas Decoration Building, #122 Zhenhua RD., Futian, Shenzhen, China



THIS DRAWING IS UNPUBLISHED. RELEASED FOR PUBLICATION  
 © COPYRIGHT - BY TYCO ELECTRONICS CORPORATION. ALL RIGHTS RESERVED.

LOC	DIST	REVISIONS					
GP	00	P	LTR	DESCRIPTION	DATE	DWN	APVD
			A	RELEASED	16MAY06	RG	SF

5 RECOMMENDED MOUNTING HARDWARE TO BE ORDERED SEPARATELY FOR REFERENCE ONLY:  
 FOR PANEL MOUNTING USE:  
 1650402-1, 8-32 SHOULDER SCREW  
 1650589-1, M4 X 0.7 SHOULDER SCREW

4. ELCON SERIES 426-0001-01100

3 ITEMS PROVIDED TO THIS SPECIFICATION TO BE PERMANENTLY IDENTIFIED PER THE FOLLOWING IDENTIFIER:

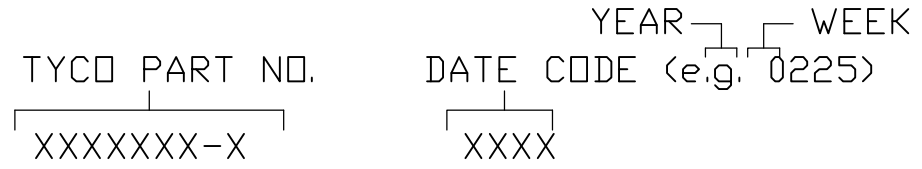

2. MATERIALS:  
 HOUSINGS: THERMOPLASTIC, GLASS REINFORCED, UL94V-0 FLAMMABILITY RATED, COLOR-BLACK.  
 RETENTION CLIPS: BERYLLIUM COPPER OR STAINLESS STEEL.

1. PART NUMBER CHANGES AND OR DESIGN CHANGES AFFECTING ITEM INTERCHANGEABILITY REQUIRE PRIOR TYCO APPROVAL AND AUTHORIZATION BY REVISION TO THIS DRAWING.

AS SHOWN	1651203-1
DESCRIPTION	PART NUMBER

THIS DRAWING IS A CONTROLLED DOCUMENT.		DWN R.GRZYBOWSKI 16MAY2006	Tyco Electronics Corporation Harrisburg, PA 17105-3608	
DIMENSIONS: INCHES		CHK S.FLICKINGER 16MAY06		
		APVD S.FLICKINGER 16MAY06	NAME P12S12 MINI DRAWER, STRAIGHT SOCKET WITH RETENTION CLIPS	
TOLERANCES UNLESS OTHERWISE SPECIFIED:		PRODUCT SPEC	-	
0 PLC ± -		APPLICATION SPEC	-	
1 PLC ± -		WEIGHT	-	
2 PLC ± .02		SIZE	A3	
3 PLC ± .010		CAGE CODE	00779	
4 PLC ± -		DRAWING NO	C-1651203	
ANGLES ± .5		RESTRICTED TO	-	
MATERIAL	FINISH	CUSTOMER DRAWING		
-	-	SCALE	1:1	
		SHEET	1 OF 3	
		REV	A	

ELCON P12S12 MINI DRAWER

THIS DRAWING IS UNPUBLISHED. RELEASED FOR PUBLICATION  
 © COPYRIGHT - BY TYCO ELECTRONICS CORPORATION. ALL RIGHTS RESERVED.

LOC	DIST	REVISIONS					
GP	00	P	LTR	DESCRIPTION	DATE	DWN	APVD
		-	-	SEE SHEET 1	-	-	-

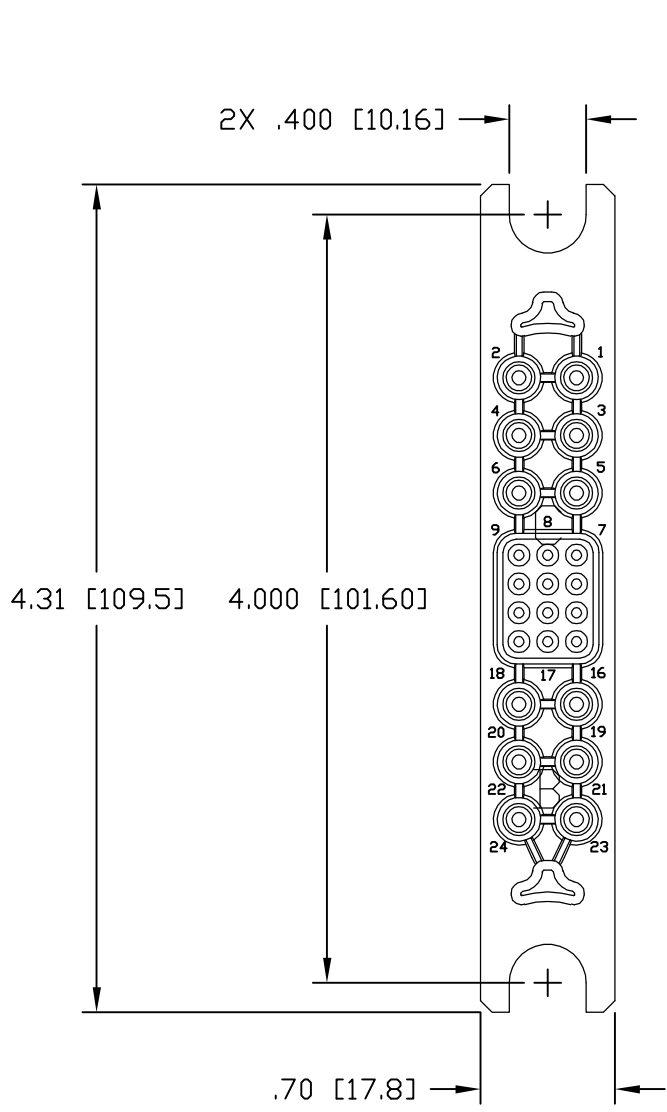

FRONT VIEW

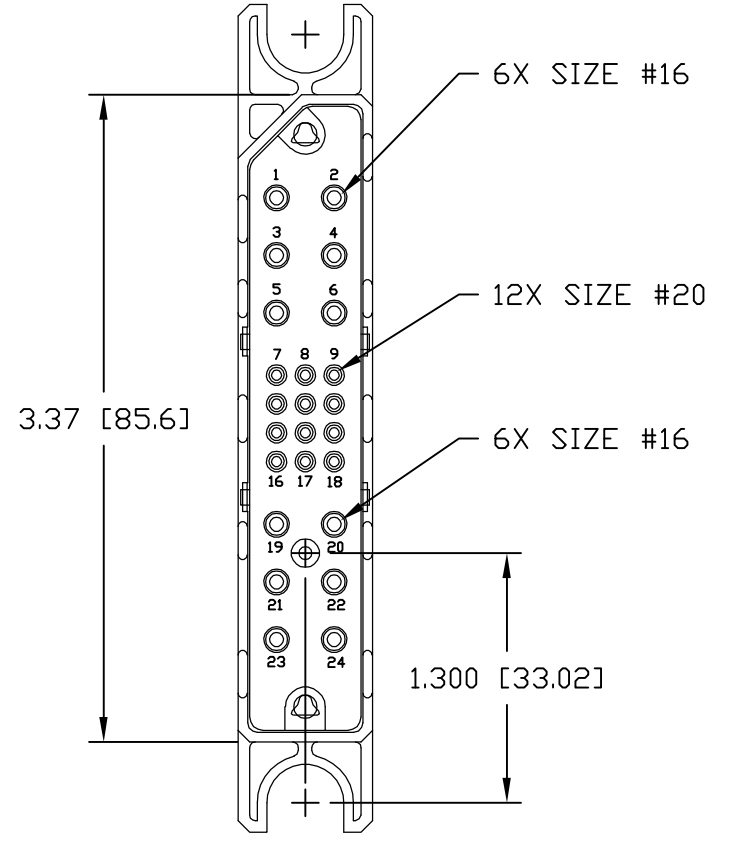
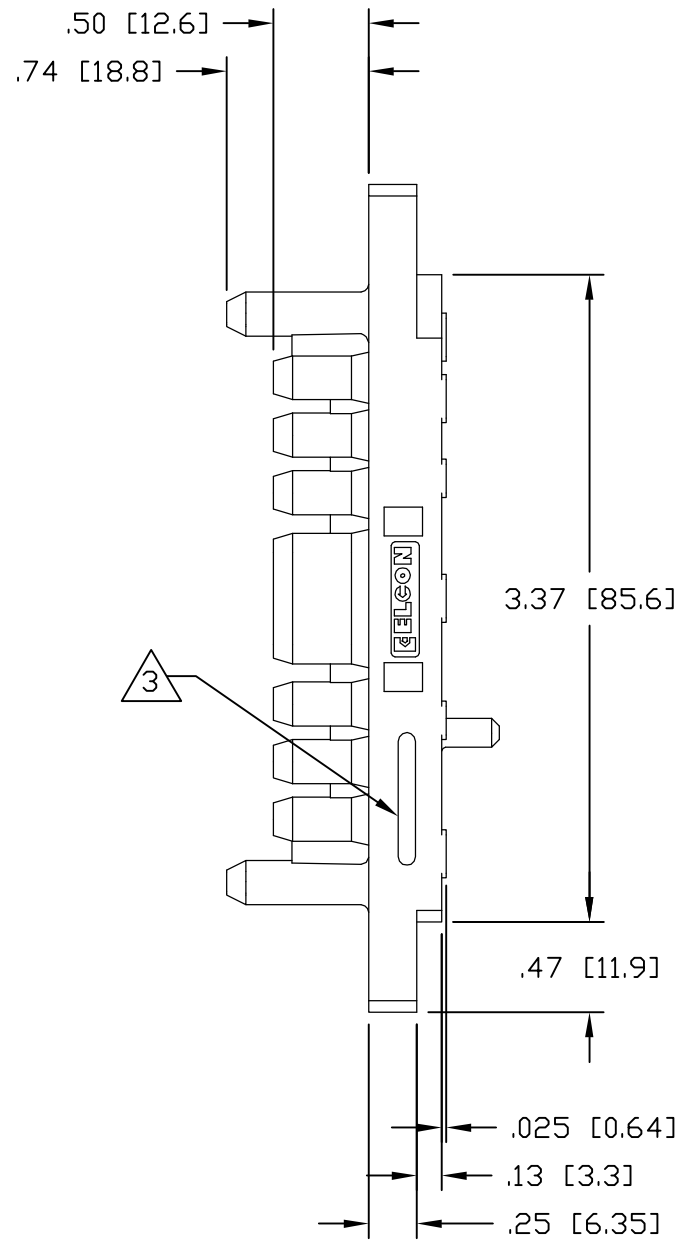

REAR VIEW

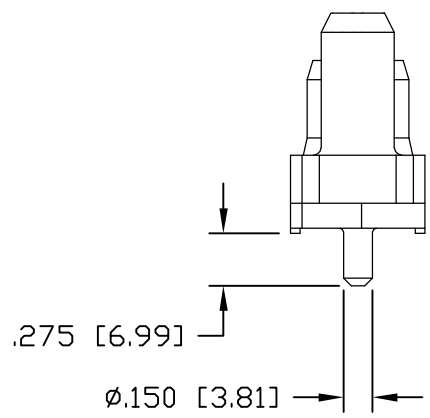
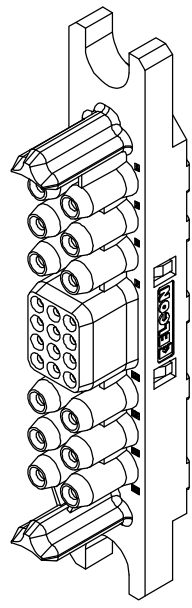

THIS DRAWING IS A CONTROLLED DOCUMENT.		DWN R.GRZYBOWSKI 16MAY2006	Tyco Electronics Corporation Harrisburg, PA 17105-3608			
DIMENSIONS: INCHES	TOLERANCES UNLESS OTHERWISE SPECIFIED: 0 PLC ± - 1 PLC ± - 2 PLC ± .02 3 PLC ± .010 4 PLC ± - ANGLES ± .5	CHK S.FLICKINGER 16MAY06	NAME			
		APVD S.FLICKINGER 16MAY06	P12S12 MINI DRAWER, STRAIGHT SOCKET WITH RETENTION CLIPS			
	MATERIAL - FINISH -	PRODUCT SPEC -	SIZE A3	CAGE CODE 00779	DRAWING NO C-1651203	RESTRICTED TO -
		APPLICATION SPEC -	CUSTOMER DRAWING		SCALE 1:1	SHEET 2 OF 3

THIS DRAWING IS UNPUBLISHED.

RELEASED FOR PUBLICATION

© COPYRIGHT BY TYCO ELECTRONICS CORPORATION. ALL RIGHTS RESERVED.

ALL RIGHTS RESERVED.

LOC GP DIST 00

REVISIONS

P	LTR	DESCRIPTION	DATE	DWN	APVD
-	-	SEE SHEET 1	-	-	-

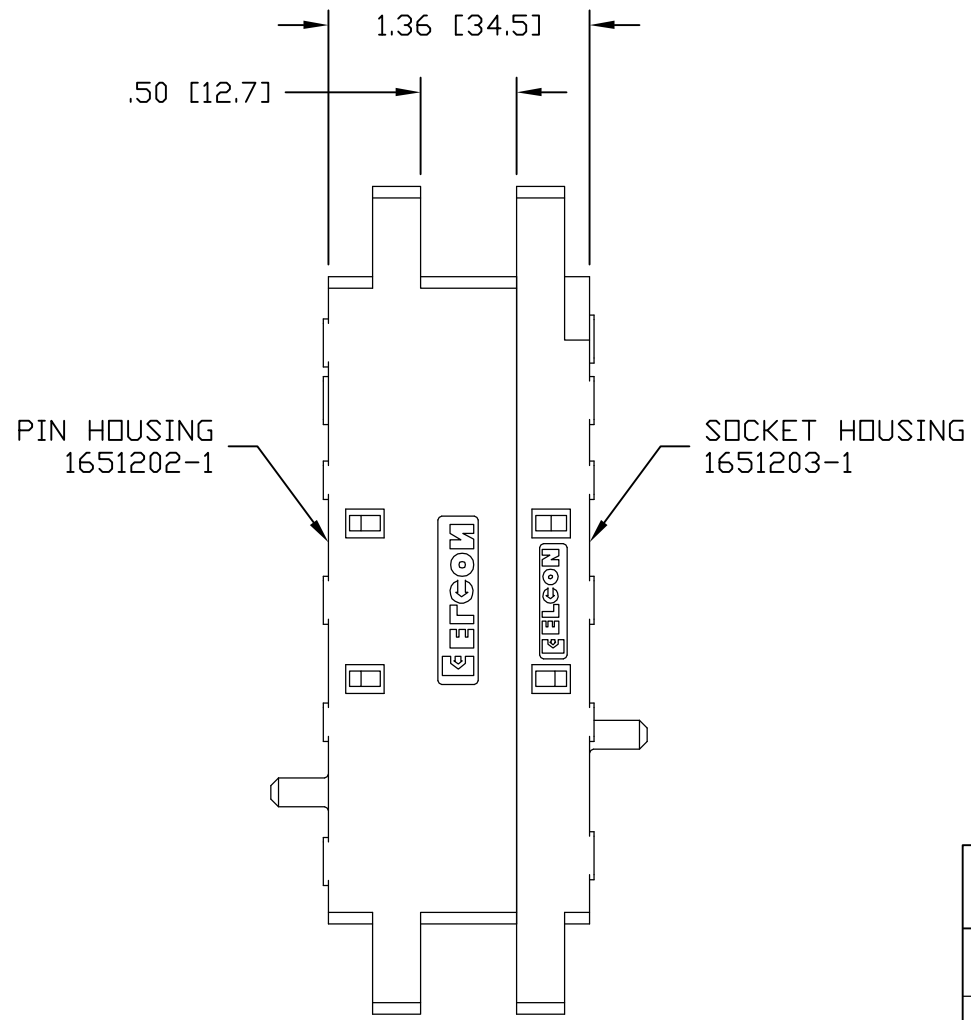
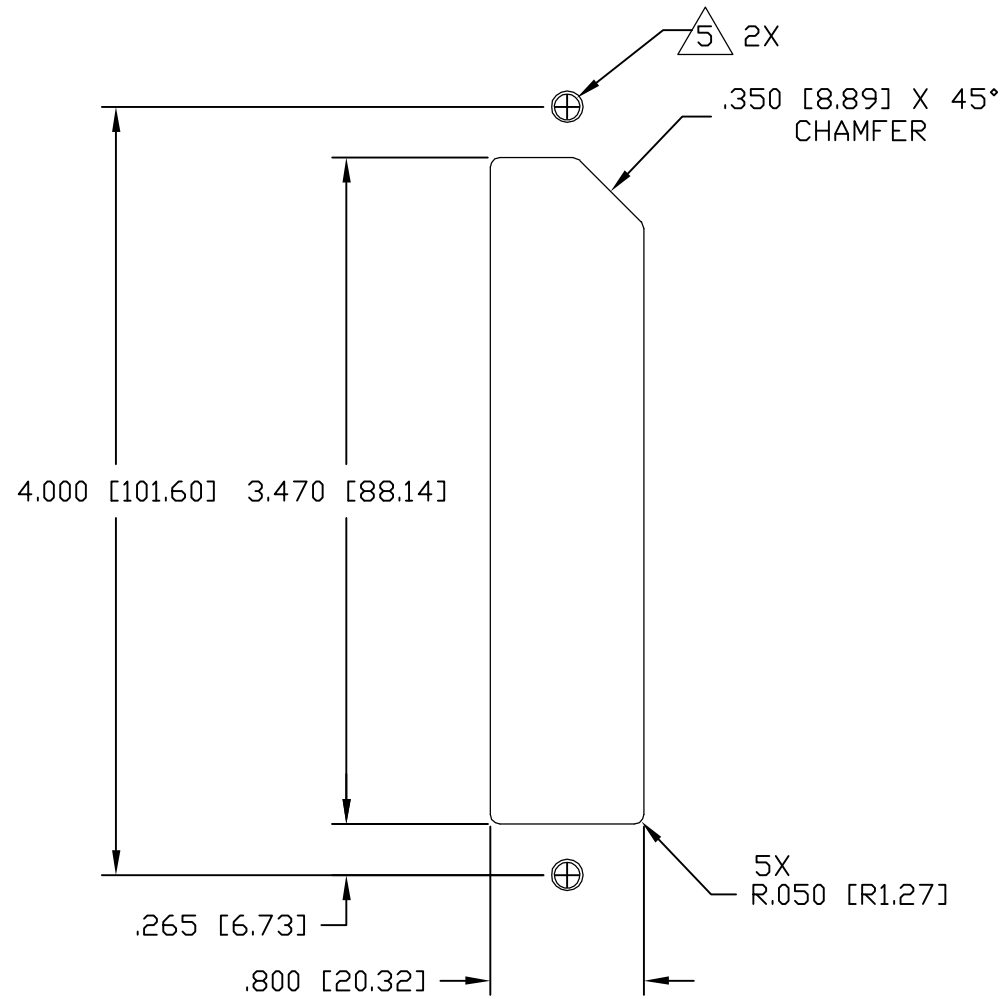
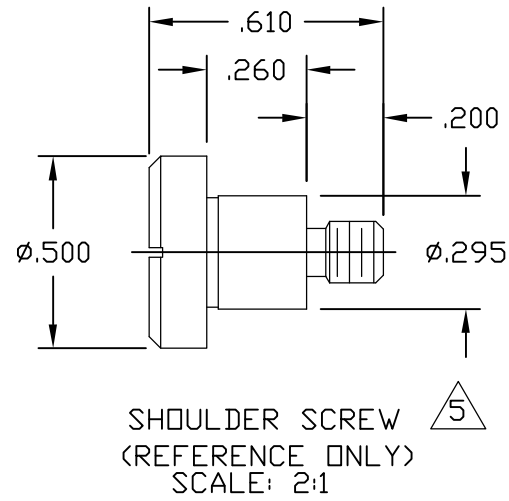

MATED CONDITION

SUGGESTED PANEL CUTOUT VIEWED FROM CONNECTOR MOUNTING SIDE

THIS DRAWING IS A CONTROLLED DOCUMENT.		DWN R.GRZYBOWSKI 16MAY2006	Tyco Electronics Corporation Harrisburg, PA 17105-3608	
DIMENSIONS: INCHES		CHK S.FLICKINGER 16MAY06	NAME	
		APVD S.FLICKINGER 16MAY06	P12S12 MINI DRAWER, STRAIGHT SOCKET WITH RETENTION CLIPS	
TOLERANCES UNLESS OTHERWISE SPECIFIED:		PRODUCT SPEC	RESTRICTED TO	
0 PLC ± -		APPLICATION SPEC	SIZE A3	CAGE CODE 00779
1 PLC ± -		WEIGHT -	DRAWING NO C-1651203	SCALE 1:1
2 PLC ± .02		CUSTOMER DRAWING		
3 PLC ± .010		SHEET 3 OF 3		
4 PLC ± -		REV A		
ANGLES ± .5				
FINISH -				