



Chipsmall Limited consists of a professional team with an average of over 10 year of expertise in the distribution of electronic components. Based in Hongkong, we have already established firm and mutual-benefit business relationships with customers from,Europe,America and south Asia,supplying obsolete and hard-to-find components to meet their specific needs.

With the principle of “Quality Parts,Customers Priority,Honest Operation,and Considerate Service”,our business mainly focus on the distribution of electronic components. Line cards we deal with include Microchip,ALPS,ROHM,Xilinx,Pulse,ON,Everlight and Freescale. Main products comprise IC,Modules,Potentiometer,IC Socket,Relay,Connector.Our parts cover such applications as commercial,industrial, and automotives areas.

We are looking forward to setting up business relationship with you and hope to provide you with the best service and solution. Let us make a better world for our industry!



Contact us

Tel: +86-755-8981 8866 Fax: +86-755-8427 6832

Email & Skype: info@chipsmall.com Web: www.chipsmall.com

Address: A1208, Overseas Decoration Building, #122 Zhenhua RD., Futian, Shenzhen, China



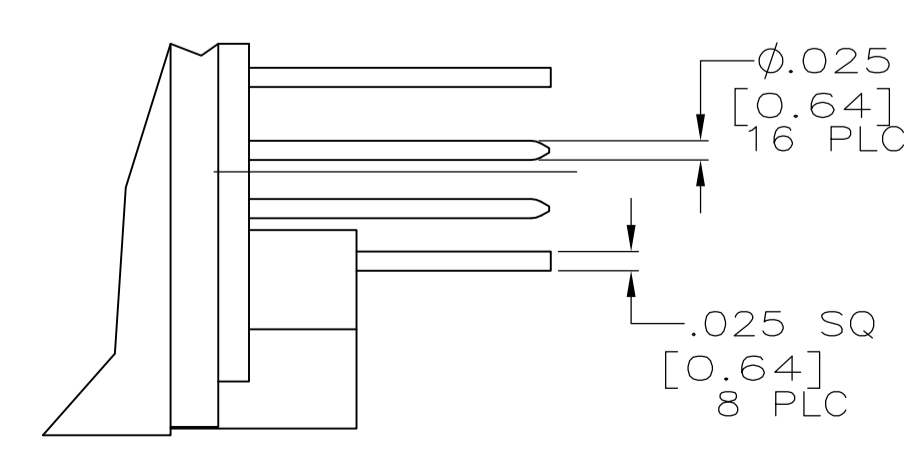
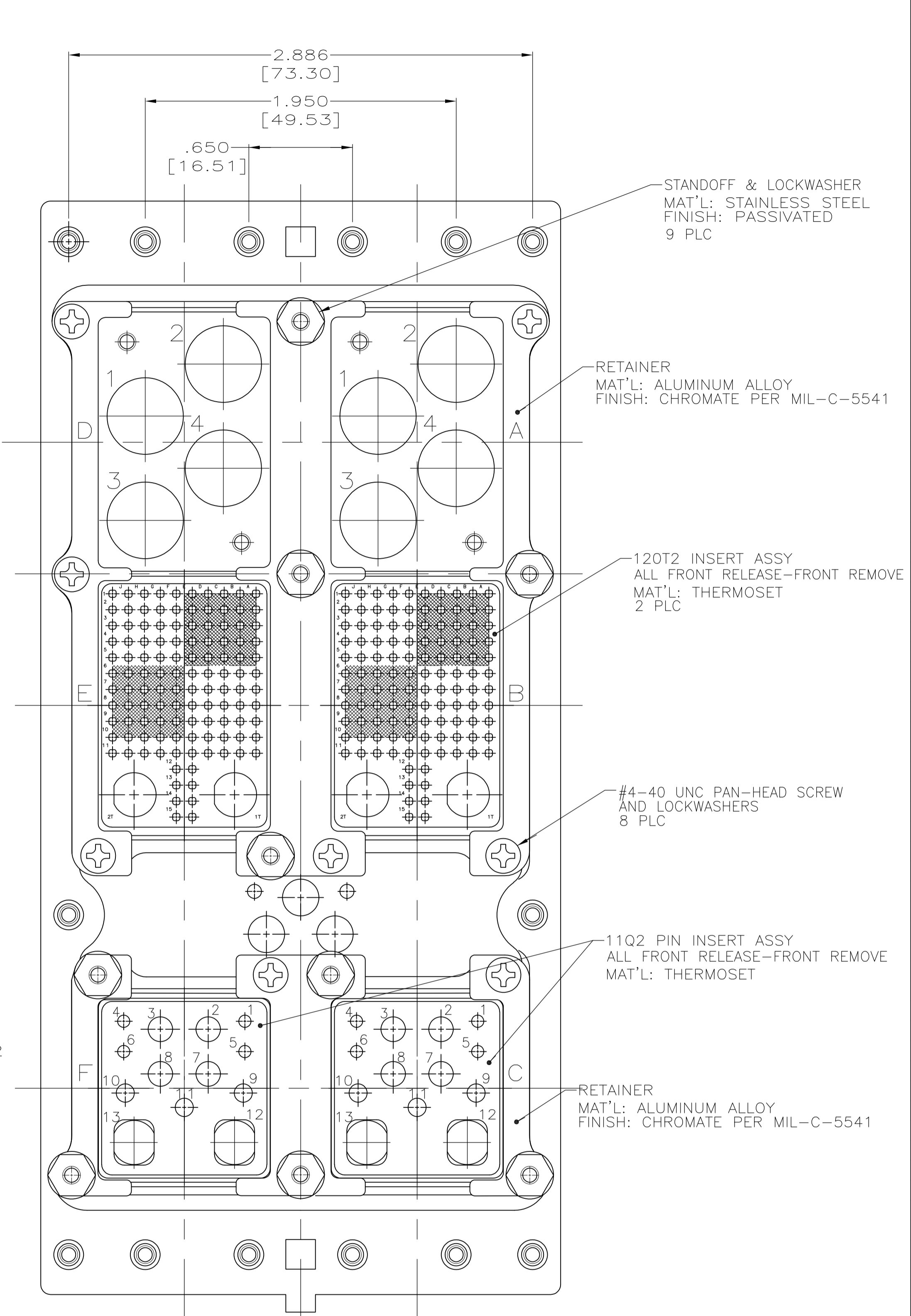
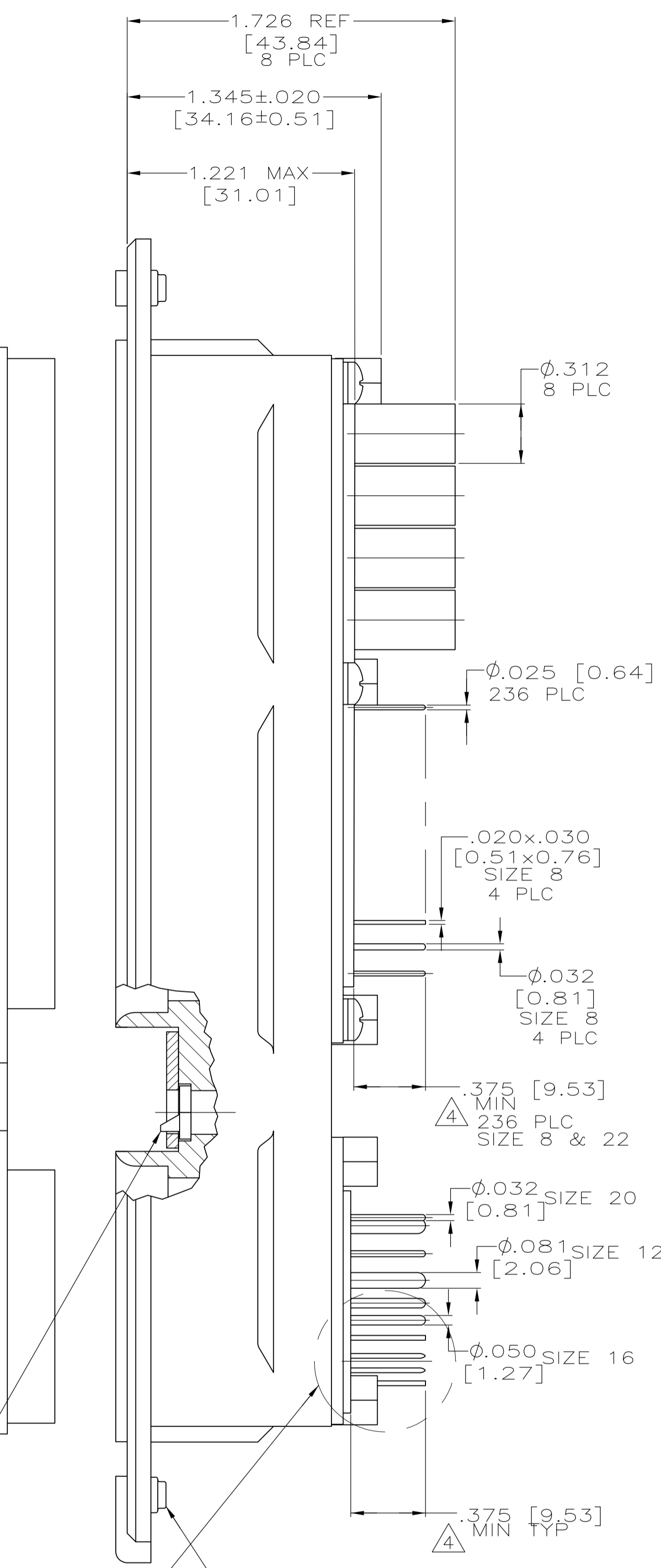
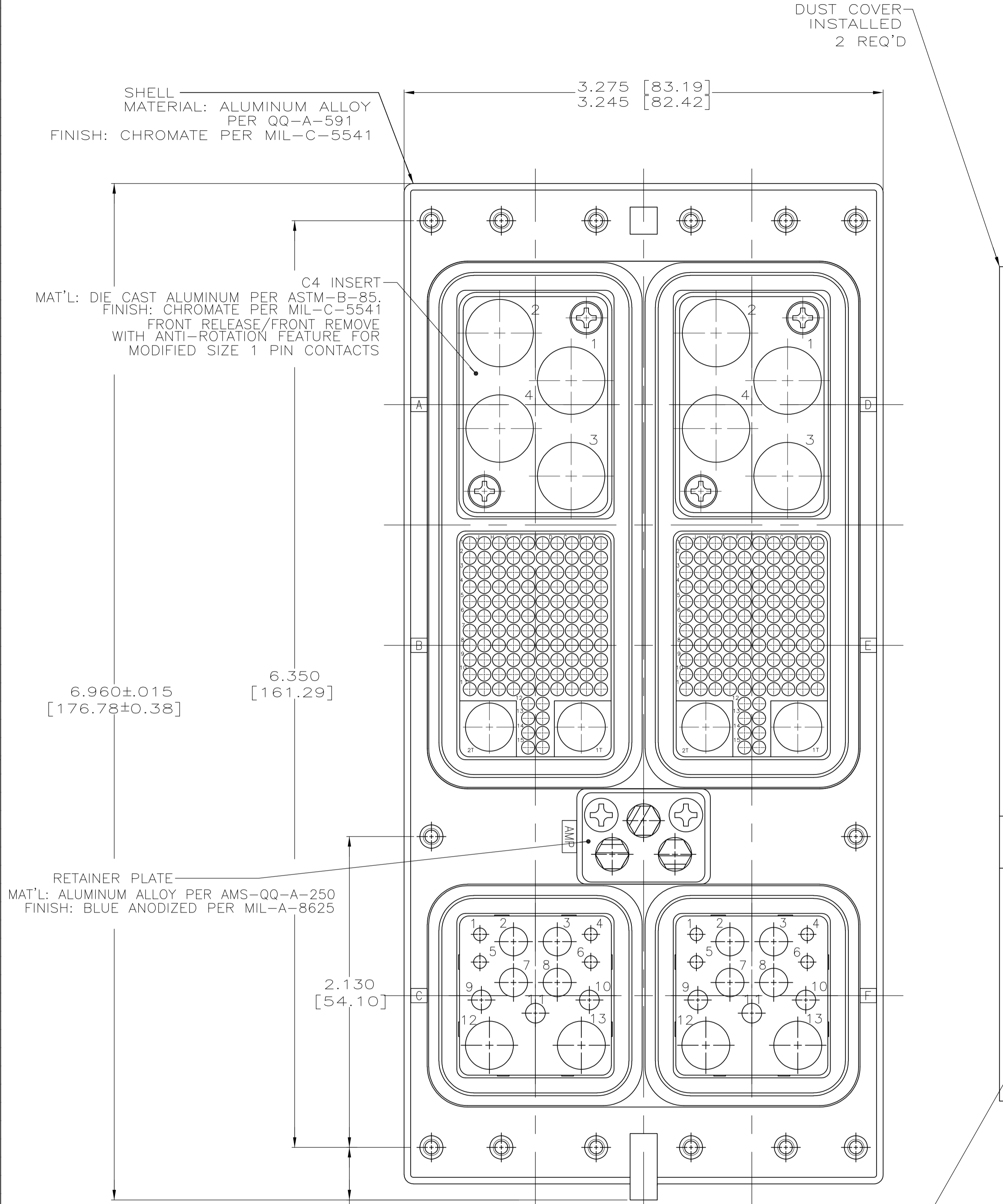

DETAIL T
SCALE 4:1
SIZE 8 QUADRAX ONLY

- CONNECTOR DIMENSIONS ARE PER ARINC 600 SPECIFICATION.
- CONNECTOR IS SUPPLIED WITH CONTACTS (PER TABLE) ASSEMBLED AS SHOWN.
- KEYING SHOWN IN POSITION "163" FOR ILLUSTRATION ONLY. CONNECTORS SHIPPED WITH KEYING INSTALLED IN POSITION PER TABLE. FOR POSITION "00" KEYING HARDWARE SHIPPED UNASSEMBLED.
- WITH CONTACT FULLY SEATED IN CAVITY.
- CONTACTS NOT SHOWN IN FRONT & REAR VIEWS FOR CLARITY.

163	MODULE A & D 1218713-1 (SIZE 1/OSP, QTY=8) MODULE B & E 211431-6 (SIZE 22, QTY=236) 448540-3 (SIZE 8, QTY=4) MODULE C & F 448140-6 (SIZE 12 POSTED, QTY=8) 2-448138-6 (SIZE 20 POSTED, QTY=8) 448139-6 (SIZE 16 POSTED, QTY=6) 1445626-2 (SIZE 8 QUADRAX POSTED, QTY=4)	1663415-1
	KEYING POSITION	CONTACTS INCLUDED AND INSTALLED

THIS DRAWING IS A CONTROLLED DOCUMENT.

DIMENSIONS: INCHES	TOLERANCES UNLESS OTHERWISE SPECIFIED:	DWN	C.C. THOMAS	5-6-03	Tyco Electronics Tyco Electronics Corporation Harrisburg, PA 17105-3608
0 PLC ± -	1 PLC ± -	APVD	S. GLATFELTER	5-6-03	
2 PLC ± -	3 PLC ± .010 [0.25]	NAME	RECEPTACLE ASSEMBLY, SIZE 3, ARINC 600 WITH QUADRAX INSERTS		
4 PLC ± -	ANGLES ± -	APPLICATION SPEC	SIZE	CAGE CODE	DRAWING NO
MATERIAL SEE CALLOUTS	FINISH SEE CALLOUTS	WEIGHT	A1	00779	1663415
CUSTOMER DRAWING			SCALE	2:1	SHEET 1 OF 1