



Chipsmall Limited consists of a professional team with an average of over 10 year of expertise in the distribution of electronic components. Based in Hongkong, we have already established firm and mutual-benefit business relationships with customers from,Europe,America and south Asia,supplying obsolete and hard-to-find components to meet their specific needs.

With the principle of “Quality Parts,Customers Priority,Honest Operation,and Considerate Service”,our business mainly focus on the distribution of electronic components. Line cards we deal with include Microchip,ALPS,ROHM,Xilinx,Pulse,ON,Everlight and Freescale. Main products comprise IC,Modules,Potentiometer,IC Socket,Relay,Connector.Our parts cover such applications as commercial,industrial, and automotives areas.

We are looking forward to setting up business relationship with you and hope to provide you with the best service and solution. Let us make a better world for our industry!



Contact us

Tel: +86-755-8981 8866 Fax: +86-755-8427 6832

Email & Skype: info@chipsmall.com Web: www.chipsmall.com

Address: A1208, Overseas Decoration Building, #122 Zhenhua RD., Futian, Shenzhen, China



REVISONS		DATE	BY	APPV
E	REV PER ECO	15-004862	4-8-15	CT WB

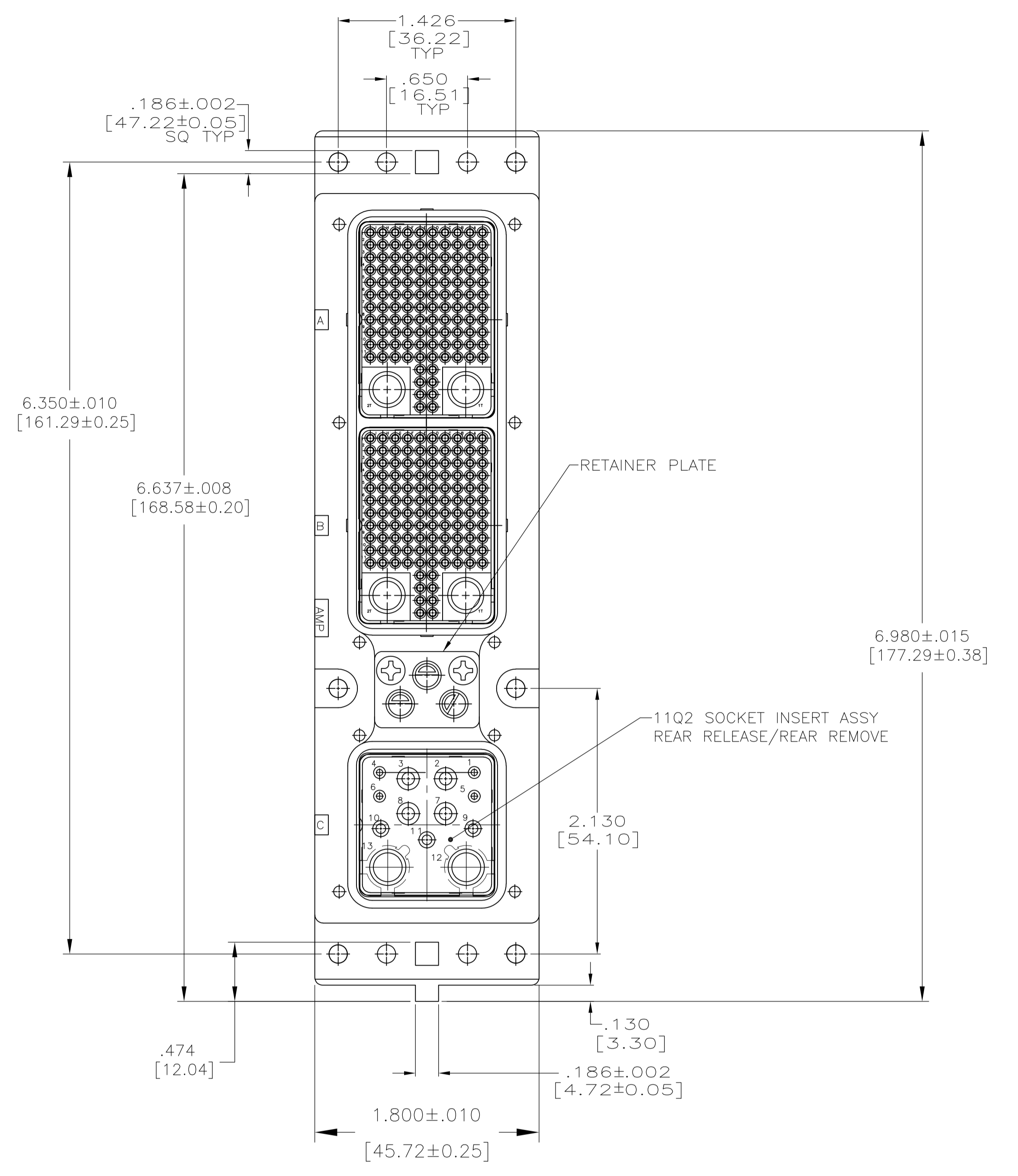
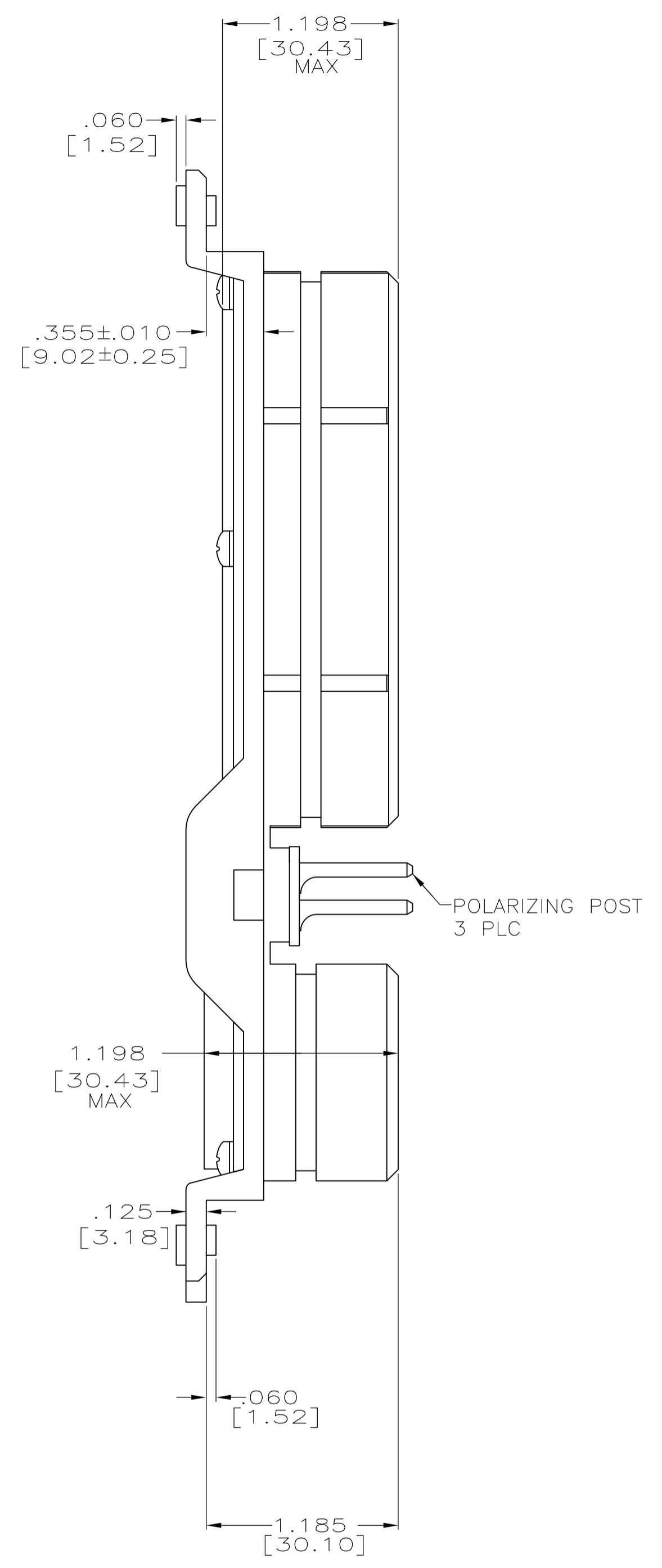
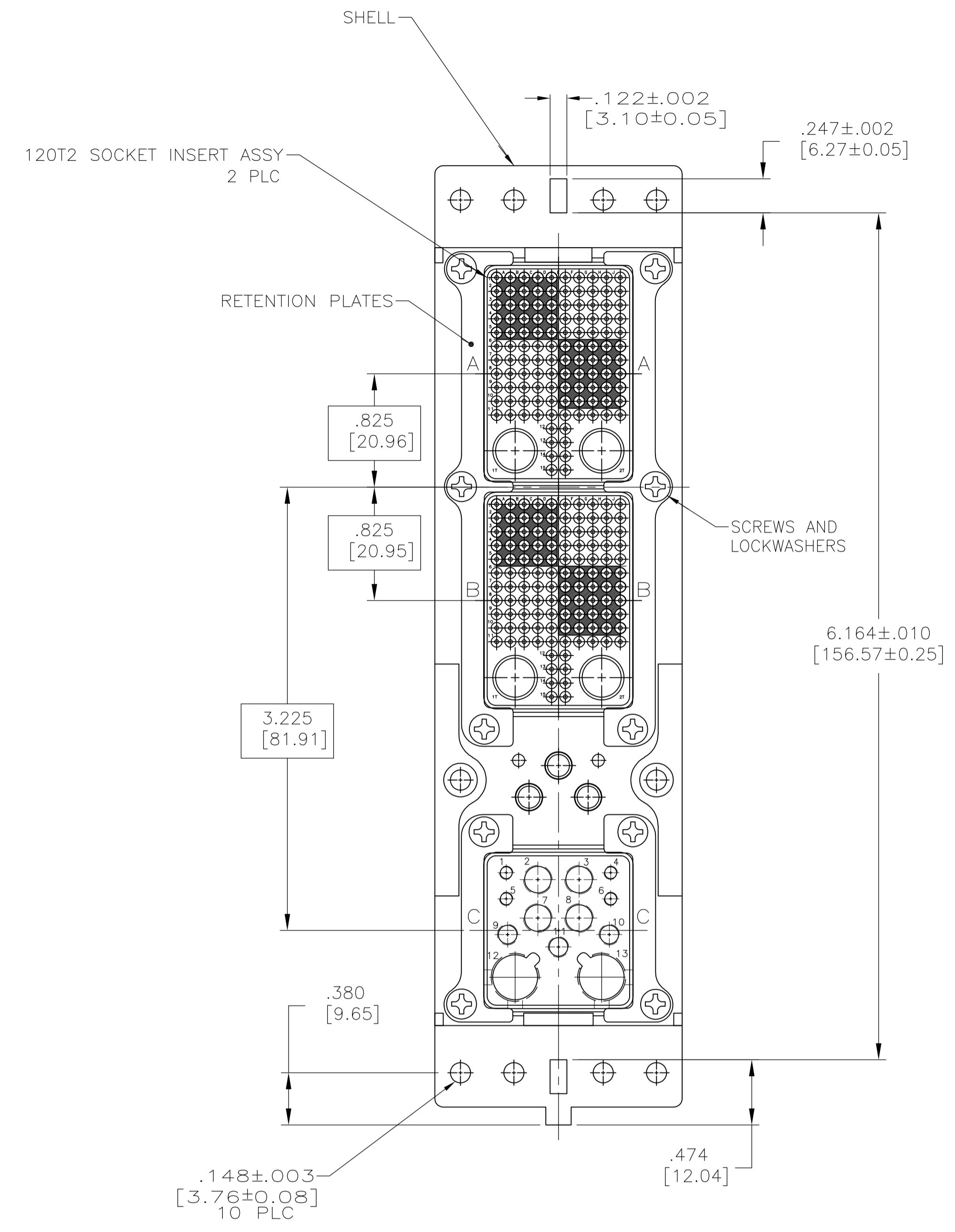

- CONNECTOR DIMENSIONS ARE PER ARINC 600 SPECIFICATION.
- CONNECTOR IS SUPPLIED WITH CONTACTS (PER TABLE), NOT INSTALLED.
- CONNECTOR IS SUPPLIED WITH A DUST COVER INSTALLED (NOT SHOWN).
- CONTACTS NOT SHOWN IN FRONT & REAR VIEWS FOR CLARITY.

COMPONENT	MATERIAL	FINISH
SHELL	DIE CAST ALUMINUM PER ASTM-B-85	CHEMICAL CONVERSION COATING PER MIL-C-5541, CLASS 1A
INSERT RETENTION PLATES	ALUMINUM ALLOY PER ASTM-B-209	CHEMICAL CONVERSION COATING PER MIL-C-5541, CLASS 1A
SCREWS AND LOCKWASHERS	STEEL OR STAINLESS STEEL	CHROMATE OVER ZINC OR PASSIVATED
POLARIZING POST	ZINC ALLOY PER ASTM-B-86	ELECTROLESS NICKEL
POLARIZING POST RETAINING PLATE	ALUMINUM ALLOY PER ASTM-B-209	BLUE ANODIZED PER MIL-A-8625
INSERTS	THERMOSET OR THERMOPLASTIC PPS PER MIL-M-24519	-
-	-	-
-	-	-

'07'	MODULE A & B 208262-3 (SIZE 22 SOCKET; QTY=2) MODULE C 208270-2 (SIZE 16 SOCKET; QTY=1) 208273-2 (SIZE 12 SOCKET; QTY=2)	1663557-2
'07'	MODULE A & B #448543-2 (SIZE 8 COAX SOCKET FOR A48909 CABLE; QTY = 4) MODULE C 208267-2 (SIZE 20 SOCKET; QTY=4) 208270-2 (SIZE 16 SOCKET; QTY=3) 208273-2 (SIZE 12 SOCKET; QTY=4) 1445693-1 (SIZE 8 QUADRAx SOCKET; QTY=2)	1663557-1
KEYING POSITION	CONTACTS INCLUDED NOT INSTALLED	PART NUMBER

THIS DRAWING IS A CONTROLLED DOCUMENT.

DIMENSIONS: INCHES [mm]
 TOLERANCES UNLESS OTHERWISE SPECIFIED:
 0 PLC ± -
 1 PLC ± -
 2 PLC ± -
 3 PLC ± .005 [0.13]
 4 PLC ± -
 ANGLES ± - 90° 90°

MATERIAL: SEE CALLOUTS
 FINISH: SEE CALLOUTS

DWG: C.C.THOMAS 6-6-03
 CHK: S.GLATFELTER 6-6-03
 APPV: S.GLATFELTER 6-6-03
 NAME: CONNECTOR ASSY, SIZE 2 PLUG, ARINC 600
 PRODUCT SPEC: -
 APPLICATION SPEC: -
 WEIGHT: -
 CUSTOMER DRAWING: -

SIZE: A1
 CAGE CODE: 00779
 DRAWING NO: 1663557
 SCALE: 3:2
 SHEET: 1 OF 1
 REV: E

TE Connectivity