



Chipsmall Limited consists of a professional team with an average of over 10 year of expertise in the distribution of electronic components. Based in Hongkong, we have already established firm and mutual-benefit business relationships with customers from,Europe,America and south Asia,supplying obsolete and hard-to-find components to meet their specific needs.

With the principle of "Quality Parts,Customers Priority,Honest Operation,and Considerate Service",our business mainly focus on the distribution of electronic components. Line cards we deal with include Microchip,ALPS,ROHM,Xilinx,Pulse,ON,Everlight and Freescale. Main products comprise IC,Modules,Potentiometer,IC Socket,Relay,Connector.Our parts cover such applications as commercial,industrial, and automotives areas.

We are looking forward to setting up business relationship with you and hope to provide you with the best service and solution. Let us make a better world for our industry!



Contact us

Tel: +86-755-8981 8866 Fax: +86-755-8427 6832

Email & Skype: info@chipsmall.com Web: www.chipsmall.com

Address: A1208, Overseas Decoration Building, #122 Zhenhua RD., Futian, Shenzhen, China



HC-M-MHR-T2-N

Order No.: 1679249



<http://eshop.phoenixcontact.de/phoenix/treeViewClick.do?UID=1679249>

HEAVYCON hinged retaining frame, for HC-B 6 sleeve housing, for 2 modules, labeling with upper case letters (A, B)

Commercial data

GTIN (EAN)	 4 017918 162627
sales group	D041
Pack	2 pcs.
Customs tariff	85369010
Catalog page information	Page 464 (PC-2009)

Product notes

WEEE/RoHS-compliant since:
10/30/2006



<http://www.download.phoenixcontact.com>
Please note that the data given here has been taken from the online catalog. For comprehensive information and data, please refer to the user documentation. The General Terms and Conditions of Use apply to Internet downloads.

Technical data

Electrical characteristics

Note	Hinged retaining frame
Ambient temperature (operation)	-40 °C ... 125 °C

Mechanical characteristics

Conductor cross-section	4 mm ² ... 6 mm ² (for PE conductor – power side)
	1 mm ² ... 2.5 mm ² (for PE conductor – control side)
Connection cross-section AWG	12 ... 10 (for PE conductor – power side)
	18 ... 14 (for PE conductor – control side)
Insertion/withdrawal cycles	≥ 500

General characteristics

Design	B6
Number of module slots	2
Assembly instructions	HC-MHR-PE16 (1636981) for PE connection extension to 16 mm ² .

Material data

Contact carrier material	Die-cast zinc alloy
--------------------------	---------------------

Certificates / Approvals



Certification GOST

Accessories

Item	Designation	Description
General		
1585155	HC-M-MHR-FIX	Fixing wedge to fix the hinged retaining frame (20 wedges on the block)
Plug/Adapter		
1636981	HC-M-MHR-PE16	Cable lug for HEAVYCON-MODULAR; PE connection extension to 16 mm ² , for crimping with crimp pliers

Diagrams/Drawings

Dimensioned drawing

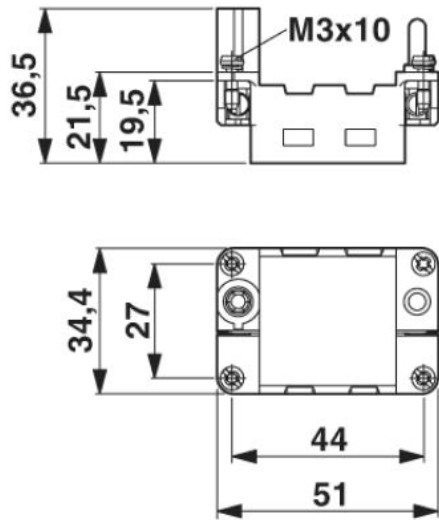

Address

PHOENIX CONTACT Deutschland GmbH
Flachmarktstr. 8
32825 Blomberg, Germany
Phone +49 5235 3 12000
Fax +49 5235 3 41200
<http://www.phoenixcontact.de>



© 2010 Phoenix Contact
Technical modifications reserved;