



Chipsmall Limited consists of a professional team with an average of over 10 year of expertise in the distribution of electronic components. Based in Hongkong, we have already established firm and mutual-benefit business relationships with customers from,Europe,America and south Asia,supplying obsolete and hard-to-find components to meet their specific needs.

With the principle of “Quality Parts,Customers Priority,Honest Operation,and Considerate Service”,our business mainly focus on the distribution of electronic components. Line cards we deal with include Microchip,ALPS,ROHM,Xilinx,Pulse,ON,Everlight and Freescale. Main products comprise IC,Modules,Potentiometer,IC Socket,Relay,Connector.Our parts cover such applications as commercial,industrial, and automotives areas.

We are looking forward to setting up business relationship with you and hope to provide you with the best service and solution. Let us make a better world for our industry!



## Contact us

Tel: +86-755-8981 8866 Fax: +86-755-8427 6832

Email & Skype: info@chipsmall.com Web: www.chipsmall.com

Address: A1208, Overseas Decoration Building, #122 Zhenhua RD., Futian, Shenzhen, China



## HC-K-KV-M32(15-21)

Order No.: 1690642

The illustration shows version HC-K-KV-M20

<http://eshop.phoenixcontact.de/phoenix/treeViewClick.do?UID=1690642>

Plastic screw connection up to 5 bar, thread length: 10 mm, cable diameter: 15 - 21 mm, WAF 36, screw connection: M32

### Commercial data

GTIN (EAN)	 4 017918 822873
sales group	D290
Pack	10 pcs.
Customs tariff	39269097
Catalog page information	Page 520 (PC-2009)

### Product notes

WEEE/RoHS-compliant since:  
02/16/2006



<http://www.download.phoenixcontact.com>  
Please note that the data given here has been taken from the online catalog. For comprehensive information and data, please refer to the user documentation. The General Terms and Conditions of Use apply to Internet downloads.

### Technical data

#### General data

Type of the screw connection	M32
Cable gland material	Polyamide, RAL 7035
Seal material	Neoprene
Cable seal material	Neoprene
Wrench size, union nut	36 mm

Wrench size, support	36 mm
Thread type connection side 1	M32
Length of the connecting thread	10.00 mm
External cable diameter	15 mm ... 21 mm
Conductor sealing range	15.00 mm ... 21.00 mm
Tightening torque, union nut	10.00 Nm
Inflammability class acc. to UL 94	V2
Degree of protection	IP68, to 5 bar
Color	Silver gray
Ambient temperature (operation)	-20 °C ... 100 °C

### Certificates / Approvals



Certification

GOST

### Diagrams/Drawings

Dimensioned drawing

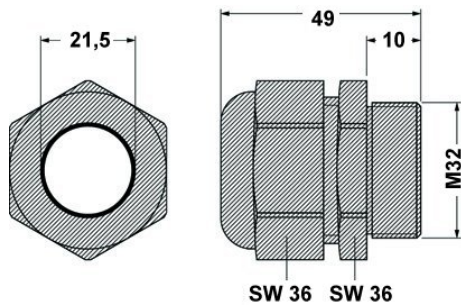

**Address**

PHOENIX CONTACT Deutschland GmbH  
Flachmarktstr. 8  
32825 Blomberg, Germany  
Phone +49 5235 3 12000  
Fax +49 5235 3 41200  
<http://www.phoenixcontact.de>



© 2010 Phoenix Contact  
Technical modifications reserved;