



Chipsmall Limited consists of a professional team with an average of over 10 year of expertise in the distribution of electronic components. Based in Hongkong, we have already established firm and mutual-benefit business relationships with customers from,Europe,America and south Asia,supplying obsolete and hard-to-find components to meet their specific needs.

With the principle of “Quality Parts,Customers Priority,Honest Operation,and Considerate Service”,our business mainly focus on the distribution of electronic components. Line cards we deal with include Microchip,ALPS,ROHM,Xilinx,Pulse,ON,Everlight and Freescale. Main products comprise IC,Modules,Potentiometer,IC Socket,Relay,Connector.Our parts cover such applications as commercial,industrial, and automotives areas.

We are looking forward to setting up business relationship with you and hope to provide you with the best service and solution. Let us make a better world for our industry!



## Contact us

Tel: +86-755-8981 8866 Fax: +86-755-8427 6832

Email & Skype: info@chipsmall.com Web: www.chipsmall.com

Address: A1208, Overseas Decoration Building, #122 Zhenhua RD., Futian, Shenzhen, China



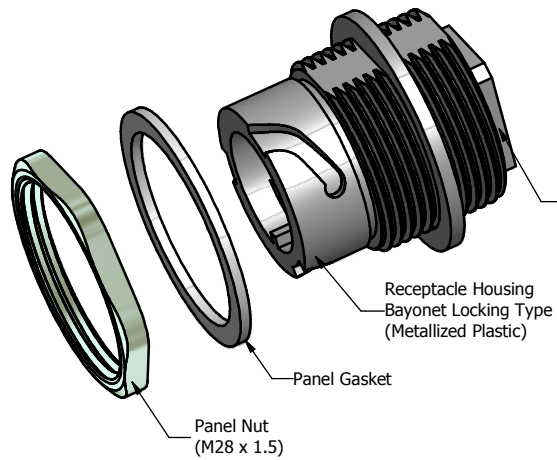

USB 2.0 Type A  
Female/Female  
Adaptor

Receptacle Housing  
Bayonet Locking Type  
(Metallized Plastic)

Panel Gasket

Panel Nut  
(M28 x 1.5)

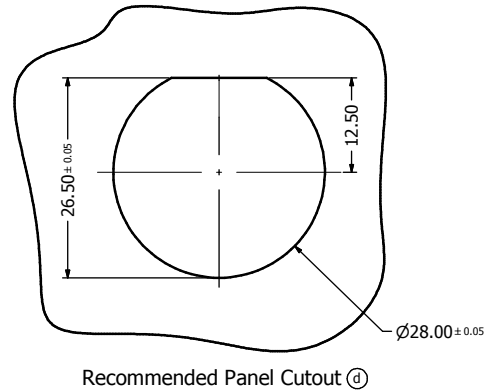

Recommended Panel Cutout (C)

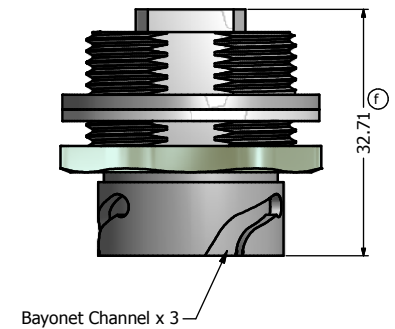

Bayonet Channel x 3

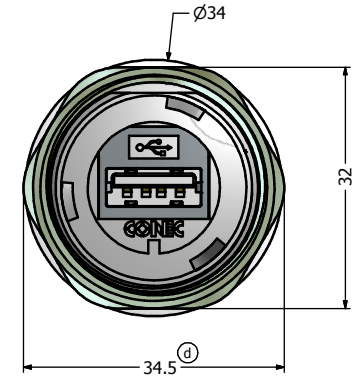
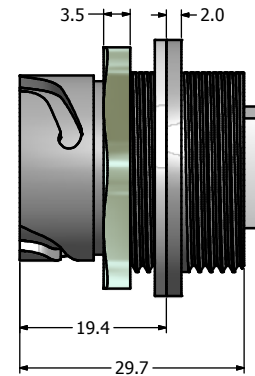
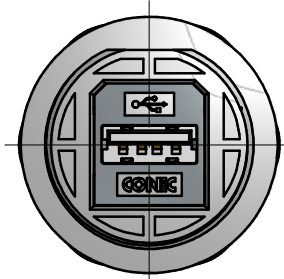

**Notes:**

- Electrical Specifications:
  - Meets USB 2.0 Specification
  - Contact Resistance: 30 mOhm max.
  - Insulation Resistance: 1000 MOhm min. @ 100 VDC
  - Current Rating: 1.5 A max. at 25° C
  - Working Voltage: 30 V (RMS) max.
  - DWV: 500 VAC/60s at sea level
  - Operating Temperature: -40° C to +85° C

2. Material and Finish:

- Ⓢ - Receptacle Housing: Metallized ABS (Nickel Plated), UL94 V-0
- Panel Nut: Brass, Finish: Nickel Plated
- Panel Gasket: Silicon, Color: White
- USB Adaptor Insulator: PBT, UL94 V-0, Black
- USB Adaptor Metal Shell: Copper Alloy, Nickel Plated
- USB Adaptor Overmold material: PBT UL94 V-0, Color: Black
- USB Contacts: Copper Alloy, Finish: 30 u" Gold min. over Nickel

3. Connector can be front or rear mounted to a maximum panel thickness of 3.2 mm.

4. IP67 rated when covered or fully mated with the appropriated mating connector

**Pin-Assignment**

Type A F	Type A F
Pin1 -----	Pin1
Pin2 -----	Pin2
Pin3 -----	Pin3
Pin4 -----	Pin4
Shell -----	Shell

Directive 2002/95/EC RoHS Compliant

THIS DRAWING MAY NOT BE COPIED OR REPRODUCED IN ANY MANNER AND MAY NOT BE PASSED ON TO A THIRD PARTY WITHOUT WRITTEN PERMISSION. OWNERSHIP AND COPYRIGHT OF CONEC CORPORATION <b>DO NOT ALTER CAD DRAWING BY HAND</b>	Customer:			Tolerance Unless otherwise specified			Scale:	Dim. in mm	
	Name	Title	Approval Date	0 PLC ±0.50	1 PLC ±0.38		2 PLC ±0.25	3 PLC ±0.10	ANGLES ±3°
	f	1 x f	May/15/2013	Vincent Ke	2008	Date	Name	Material: See Notes	
	e	1 x e	Nov/03/2011	Vincent Ke	Draw.	Sept. 09	Vincent Ke	Title: IP67 USB Receptacle Assembly Kit with USB 2.0 Type A F/ F Adaptor	
d	1 x d	Mar/08/2011	Vincent Ke	Appd.	Sept. 09	J. Chaudry	Drawing No.: 39K1A361		
c	2 x c	Mar/18/2010	Vincent Ke	Norm			Part No.: 17-200011		
b	1 x b	Jun/01/2009	Vincent ke	D-old			DIN A3		
a	original						Sheet 1/1		
Rev.	Changes	Date	Name						