



Chipsmall Limited consists of a professional team with an average of over 10 year of expertise in the distribution of electronic components. Based in Hongkong, we have already established firm and mutual-benefit business relationships with customers from,Europe,America and south Asia,supplying obsolete and hard-to-find components to meet their specific needs.

With the principle of “Quality Parts,Customers Priority,Honest Operation,and Considerate Service”,our business mainly focus on the distribution of electronic components. Line cards we deal with include Microchip,ALPS,ROHM,Xilinx,Pulse,ON,Everlight and Freescale. Main products comprise IC,Modules,Potentiometer,IC Socket,Relay,Connector.Our parts cover such applications as commercial,industrial, and automotives areas.

We are looking forward to setting up business relationship with you and hope to provide you with the best service and solution. Let us make a better world for our industry!



Contact us

Tel: +86-755-8981 8866 Fax: +86-755-8427 6832

Email & Skype: info@chipsmall.com Web: www.chipsmall.com

Address: A1208, Overseas Decoration Building, #122 Zhenhua RD., Futian, Shenzhen, China



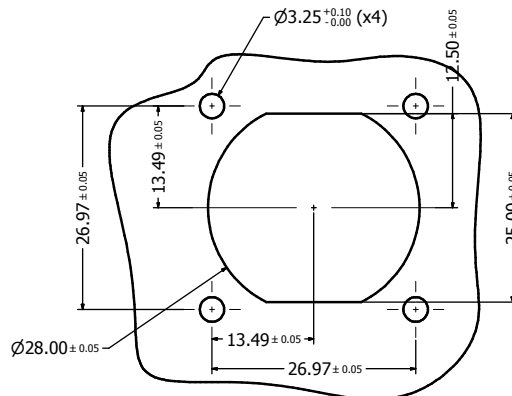
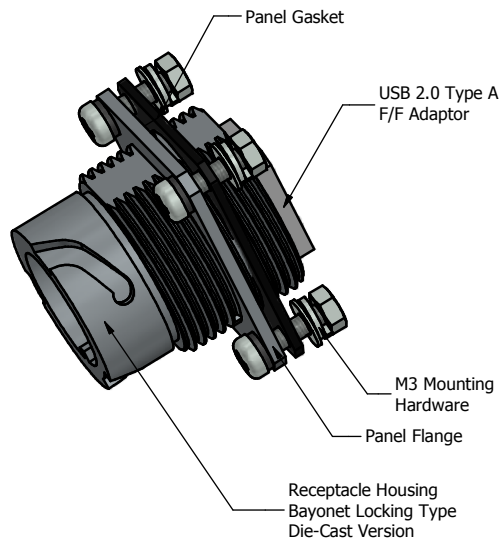

Recommended Double-D Panel Cutout

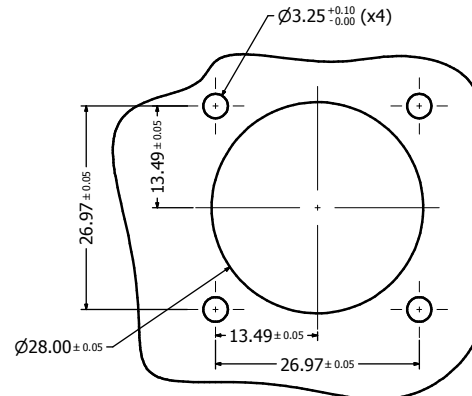

Recommended Round Panel Cutout

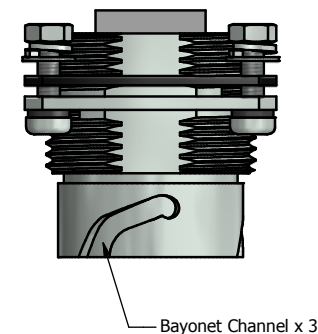

Bayonet Channel x 3

Notes:

- Electrical Specifications:
 - Meets USB 2.0 Specification
 - Contact Resistance: 30 mOhm max.
 - Insulation Resistance: 1000 MOhm min. @ 100 VDC
 - Current Rating: 1.5 A max. at 25°C
 - Working Voltage: 30 V (RMS) max.
 - DWV: 500 VAC/60s at sea level
 - Operating Temperature: -40°C to +85°C
- Material and Finish:
 - Receptacle Housing (with Flange): Zinc Die-Cast, Finish: Powercron 150 (PPG), Black
 - Panel Gasket: NBR, Color: Black
 - M3 Mounting Hardware: Stainless Steel
 - Includes 4 x (Screw + Nut + Flat Washer + Spring Lock Washer)
 - USB Adaptor Insulator: PBT, UL94 V-0, Black
 - USB Adaptor Metal Shell: Copper Alloy, Nickel Plated
 - USB Adaptor Overmold material: PBT UL94 V-0, Color: Black
 - USB Contacts: Copper Alloy, Finish: 30 u" Gold min. over Nickel
- Connector can be front or rear mounted to a maximum panel thickness of 3.2 mm.
- IP67 rated when fully mated with appropriate mating connector
- Hardware shipped unassembled
- Recommended mounting torque is 8 to 10 lb-inch

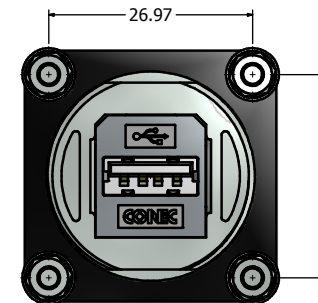
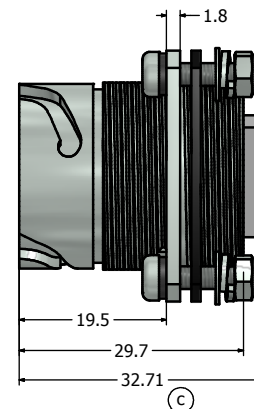
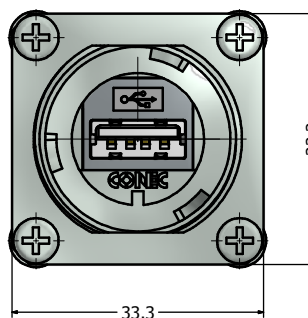

Pin-Assignment

Type A Female	Type A Female
Pin1 ----- Pin1	Pin1 ----- Pin1
Pin2 ----- Pin2	Pin2 ----- Pin2
Pin3 ----- Pin3	Pin3 ----- Pin3
Pin4 ----- Pin4	Pin4 ----- Pin4
Shell ----- Shell	Shell ----- Shell

Directive 2002/95/EC RoHS Compliant

THIS DRAWING MAY NOT BE COPIED OR REPRODUCED IN ANY MANNER AND MAY NOT BE PASSED ON TO A THIRD PARTY WITHOUT WRITTEN PERMISSION. OWNERSHIP AND COPYRIGHT OF CONEC CORPORATION.	Customer:			Tolerance Unless otherwise specified			Scale:	Dim. in mm		
	Name		Title	Approval Date	0 PLC ± 0.30		Autodesk Inventor	Material: See Notes		
					1 PLC ± 0.20	2012		Date	Name	
					2 PLC ± 0.10	Draw.		Sept. 27	Vincent Ke	
				3 PLC ± 0.05	Appd.	Sept. 27	J. Chaudry	IP67 USB Type A F/F Adaptor Receptacle (with Flange) Assembly Kit Nickel Plated Zinc Die-Cast Version		
				ANGLES ± 1°				Drawing No.: 17K1A354		
					c	1 x c	May/22/2013	Vincent ke	D-old	DIN A3
					b	1 x b	Mar/05/2013	Vincent Ke		Sheet 1/1
					a	original				
					Rev.	Changes	Date	Name		
									Part No.: 17-210111	