



Chipsmall Limited consists of a professional team with an average of over 10 year of expertise in the distribution of electronic components. Based in Hongkong, we have already established firm and mutual-benefit business relationships with customers from,Europe,America and south Asia,supplying obsolete and hard-to-find components to meet their specific needs.

With the principle of “Quality Parts,Customers Priority,Honest Operation,and Considerate Service”,our business mainly focus on the distribution of electronic components. Line cards we deal with include Microchip,ALPS,ROHM,Xilinx,Pulse,ON,Everlight and Freescale. Main products comprise IC,Modules,Potentiometer,IC Socket,Relay,Connector.Our parts cover such applications as commercial,industrial, and automotives areas.

We are looking forward to setting up business relationship with you and hope to provide you with the best service and solution. Let us make a better world for our industry!



Contact us

Tel: +86-755-8981 8866 Fax: +86-755-8427 6832

Email & Skype: info@chipsmall.com Web: www.chipsmall.com

Address: A1208, Overseas Decoration Building, #122 Zhenhua RD., Futian, Shenzhen, China



Revision level Indice Aenderungsstand		Revision Record Désignation Beschreibung der Aenderung	Changed Modifié Geändert	Date Datum	Approved Approuvé Geprüft	Date Datum
Drawing Dessin Zeichnung	Part Pièce Solid					
1		Typ HEGPA6614 in Tabelle hinzu	Langeloh	06.11.06	Schiwek	06.11.06
2		Tabelle mit Laengentoleranzen hinzu	Langeloh	22.11.06	Schiwek	22.11.06
3		Typ HEGPA6622 in Tabelle hinzu	Langeloh	22.01.07	Schiwek	22.01.07
4		Toleranz ±8 war ±10mm.	Mueller	01.09.10	Schiwek	01.09.10

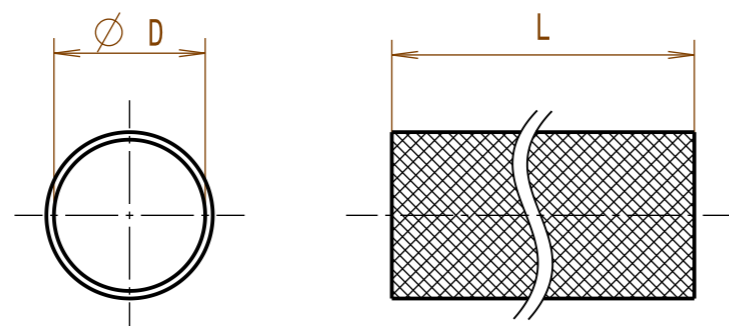

Typ/Type	nominal Ø D
HEGPA6603	3
HEGPA6604	4
HEGPA6605	5
HEGPA6606	6
HEGPA6608	8
HEGPA6610	10
HEGPA6612	12
HEGPA6614	14
HEGPA6616	16
HEGPA6620	20
HEGPA6622	22
HEGPA6625	25
HEGPA6630	30
HEGPA6640	40
HEGPA6650	50
HEGPA6660	60

L	Tol.
bis/to 500	±8mm
> 500	±1,5% der Laenge/ of the length

Temperaturbestaendigkeit
Temperature stability

-60°C bis +150°C/
-60°C to +150°C

Material
Matière
Werkstoff

PA 6.6

Tolerances
Dimension without tolerances
details to:

Tolérances
Cotes sans tolérances:

Toleranzen
Masse ohne
Toleranzangaben nach:

PERFORMANCE
SPECIFICATION
AUSFUEHRUNG
SPEZIFIKATION

Abweichende Toleranzen nach Vereinbarung/
Deviating tolerances according to agreement

The copyright of this drawing is reserved by HELLERMANN TYTON. It is issued on condition that it is not reproduced, copied or disclosed to a third party, either wholly or in part, without the consent of HELLERMANN TYTON.

La propriété de ce plan est réservée à la société HELLERMANN TYTON. Il est distribué à condition qu'il ne soit pas reproduit, communiqué ou révélé à une tierce partie, soit complètement ou en partie, sans le consentement de la société HELLERMANN TYTON.

Weitergabe sowie Vervielfaeltigung dieser Unterlage, Verwertung und Mitteilung ihres Inhalts nicht gestattet, soweit nicht ausdruecklich zugestanden. Zuwiderhandlungen verpflichten zu Schadenersatz. Alle Rechte fuer den Fall der Patenterteilung oder Gebrauchsmuster-Eintragung vorbehalten.

Drawn
Dessiné Par
Gezeichnet

Langeloh

18.10.06

Approved
Approuvé Par
Geprüft

Schiwek

18.10.06

HellermannTyton

Manchester

Telephone: +44 (0) 161 945 4181
Facsimile: +44 (0) 161 947 2228

Trappes

Téléphone: +33 (0) 1 30 13 80 00
Télécopie: +33 (0) 1 30 13 80 60

Tornesch

Telefon: +49 (0) 41 22 / 701 - 1
Telefax: +49 (0) 41 22 / 701 - 400

Scale
Echelle
Maszstab

·/·

Project Number
Numéro de projet
Projektnummer

Title
Titre
Benennung **Braided sleeve HEGPA66...**

Helagaine Geflechschlauch HEGPA66...

Drawing-No
Plan-No
Zeichnungs-Nr

14.1993

Format
D.Size **A3**

Sheet
Page
Blatt **1 / 1**