



Chipsmall Limited consists of a professional team with an average of over 10 year of expertise in the distribution of electronic components. Based in Hongkong, we have already established firm and mutual-benefit business relationships with customers from,Europe,America and south Asia,supplying obsolete and hard-to-find components to meet their specific needs.

With the principle of “Quality Parts,Customers Priority,Honest Operation,and Considerate Service”,our business mainly focus on the distribution of electronic components. Line cards we deal with include Microchip,ALPS,ROHM,Xilinx,Pulse,ON,Everlight and Freescale. Main products comprise IC,Modules,Potentiometer,IC Socket,Relay,Connector.Our parts cover such applications as commercial,industrial, and automotives areas.

We are looking forward to setting up business relationship with you and hope to provide you with the best service and solution. Let us make a better world for our industry!



## Contact us

Tel: +86-755-8981 8866 Fax: +86-755-8427 6832

Email & Skype: info@chipsmall.com Web: www.chipsmall.com

Address: A1208, Overseas Decoration Building, #122 Zhenhua RD., Futian, Shenzhen, China



**PROPER USE GUIDELINES**

Cumulative Trauma Disorder can result from the prolonged use of manually powered hand tools. NorComp hand tools are intended for the occasional use and low volume applications. NorComp offers a wide selection of powered application equipment for extended use, production operations.

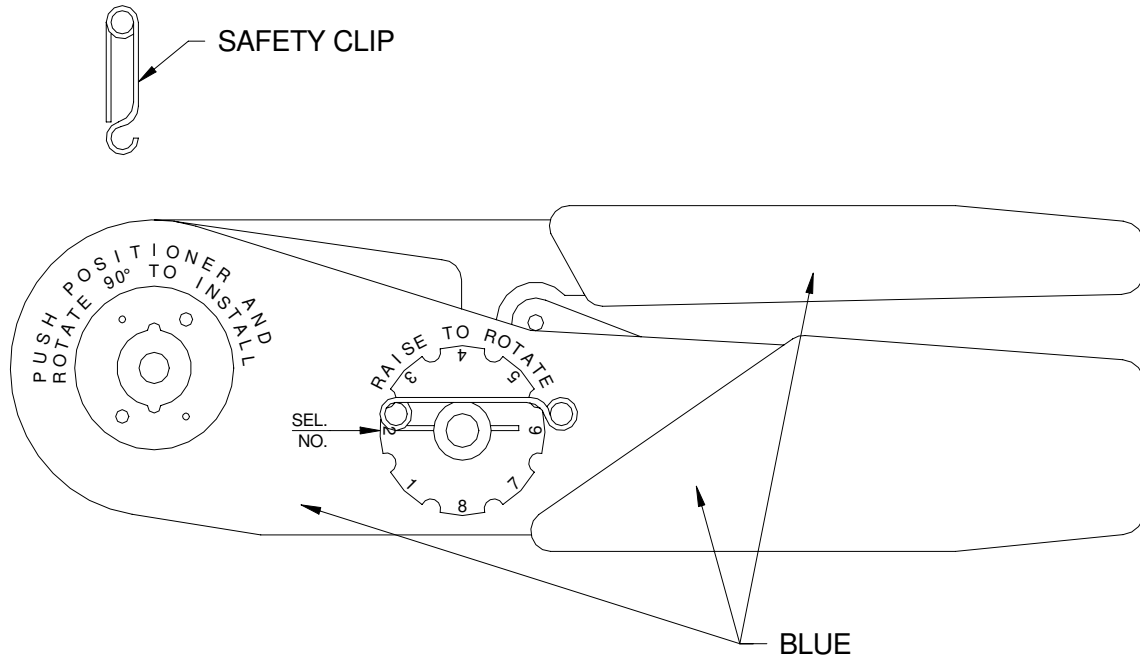

Figure 1

**1. GENERAL INFORMATION**

NorComp 170-702-170-000 Hand Tool Assembly refers to basic hand tool with positioner (K1290). Hand Tool Assembly is used to crimp NorComp contacts, part numbers:

- 170-201-170L002      170-202-170L002
- 170-201-170L003      170-202-170L003

Wire crimp range 26 AWG to 20 AWG.  
Recommended strip length: 0.150in. [3.81mm]

The tool has a double action ratchet. The tool cannot be opened without completing the cycle.

**2. TOOL PREPARATION**

- a. The tool must be in the open position.
- b. Remove safety clip from positioner guide.
- c. Insert positioner into positioner guide and turn 90 degrees until bayonet pins lock.

- d. Install safety clip into positioner guide.
- e. Wire size and corresponding selector number are shown on data plate.

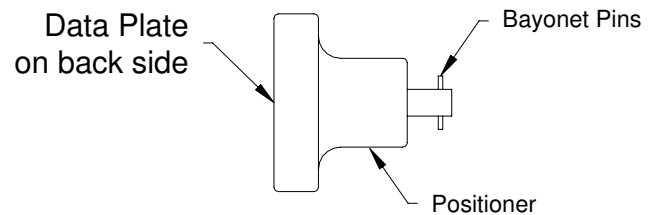

Figure 2

- f. With tool still in open position, raise, and rotate selector knob until number indicated on data plate for wire size to be crimped is in line with selector number arrow.

### 3. CRIMPING INSTRUCTIONS

- a. Insert contact and prepared wire into indenter opening from side opposite the positioner.
- b. Squeeze handles together until ratchet releases. Handle will return to the open position. Remove crimped contact and wire.

### 4. CRIMP TEST

Test each crimp using Table 1.

WIRE SIZE Max AWG	PULL TEST lb.
20	12
22	10
24	8
26	6

Table 1

### 5. REMOVING POSITIONER

Remove safety clip and reverse procedure described in step 2.d. above.

### 6. MAINTENANCE

There is virtually no maintenance required. However, it is a good practice to keep indenter tips free of residual and other debris. A small wire brush may be used for this purpose.

We strongly recommend that you:

- DO NOT immerse tool in cleaning solution
- DO NOT spray oil into tool to lubricate
- DO NOT attempt to disassemble tool to make repairs

This is a precision crimp tool and should be handled with care.

### 7. VISUAL INSPECTION

The crimping tool should be inspected on a regular basis to ensure that it has not become worn or damaged. If damage or abnormal wear is evident, the tool must be replaced.