



Chipsmall Limited consists of a professional team with an average of over 10 year of expertise in the distribution of electronic components. Based in Hongkong, we have already established firm and mutual-benefit business relationships with customers from,Europe,America and south Asia,supplying obsolete and hard-to-find components to meet their specific needs.

With the principle of “Quality Parts,Customers Priority,Honest Operation,and Considerate Service”,our business mainly focus on the distribution of electronic components. Line cards we deal with include Microchip,ALPS,ROHM,Xilinx,Pulse,ON,Everlight and Freescale. Main products comprise IC,Modules,Potentiometer,IC Socket,Relay,Connector.Our parts cover such applications as commercial,industrial, and automotives areas.

We are looking forward to setting up business relationship with you and hope to provide you with the best service and solution. Let us make a better world for our industry!



## Contact us

Tel: +86-755-8981 8866 Fax: +86-755-8427 6832

Email & Skype: info@chipsmall.com Web: www.chipsmall.com

Address: A1208, Overseas Decoration Building, #122 Zhenhua RD., Futian, Shenzhen, China



THIS DRAWING IS UNPUBLISHED  
 VERTRÄULICHE UNVERÖFFENTLICHTE ZEICHNUNG  
 RELEASED FOR PUBLICATION  
 FREI FÜR VERÖFFENTLICHUNG  
 SEP 2008  
 MATED WITH:  
 PASSEND ZU:  
 1703998  
 COPYRIGHT 2008 BY TYCO ELECTRONICS CORPORATION. ALL RIGHTS RESERVED.  
 ALLE RECHTE VORBEHALTEN

LOC	DIST	REVISIONS				
		AENDERUNGEN	DESCRIPTION	DATE	DWN	APVD
		BESCHREIBUNG				
A1	-					
PROJEKT NR.:						
EGATN08024						

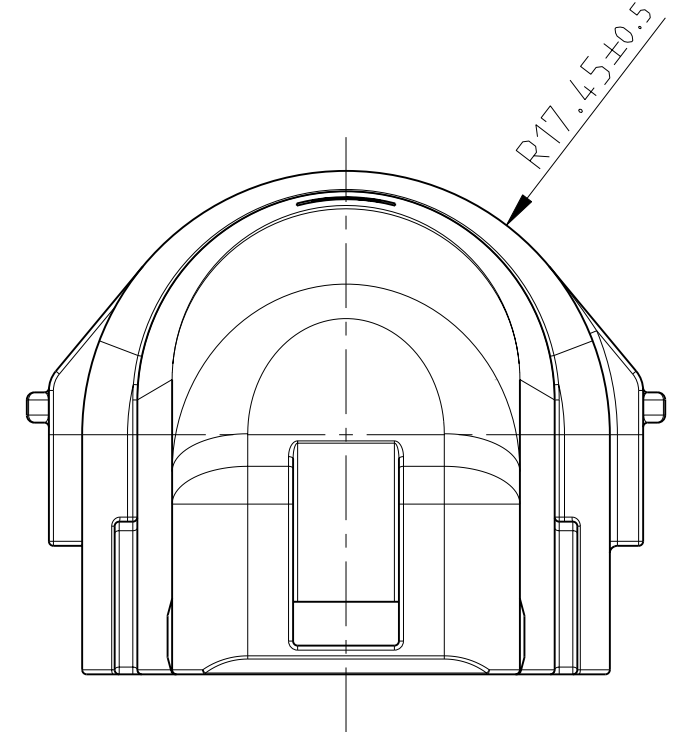
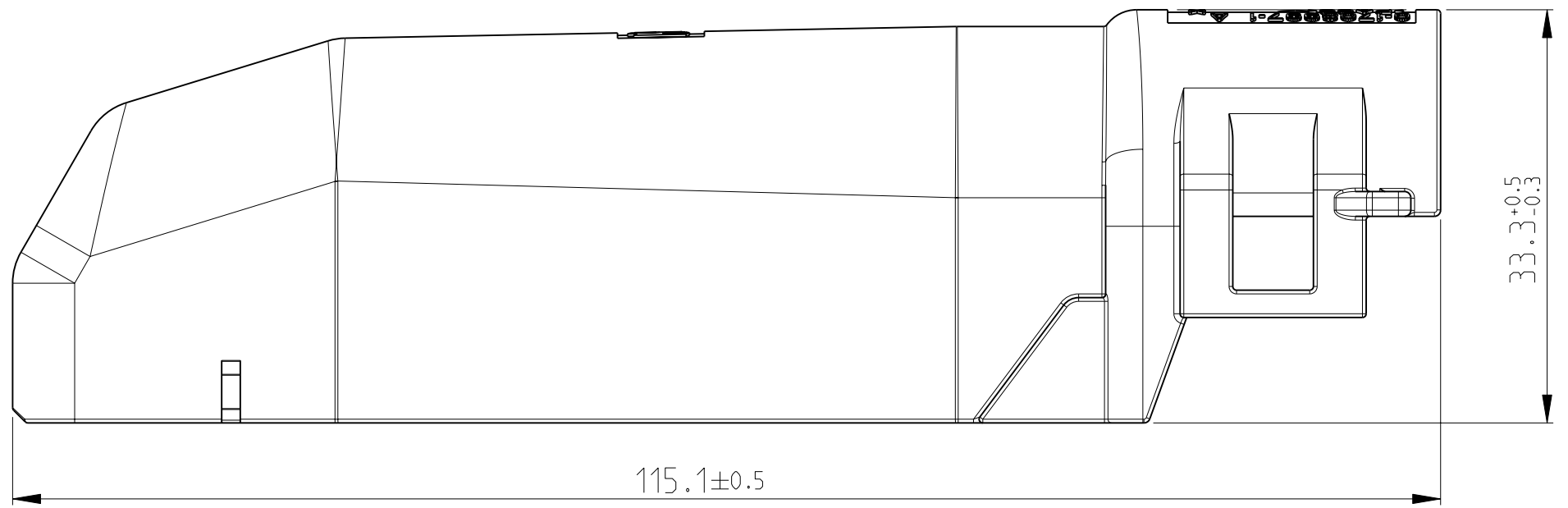
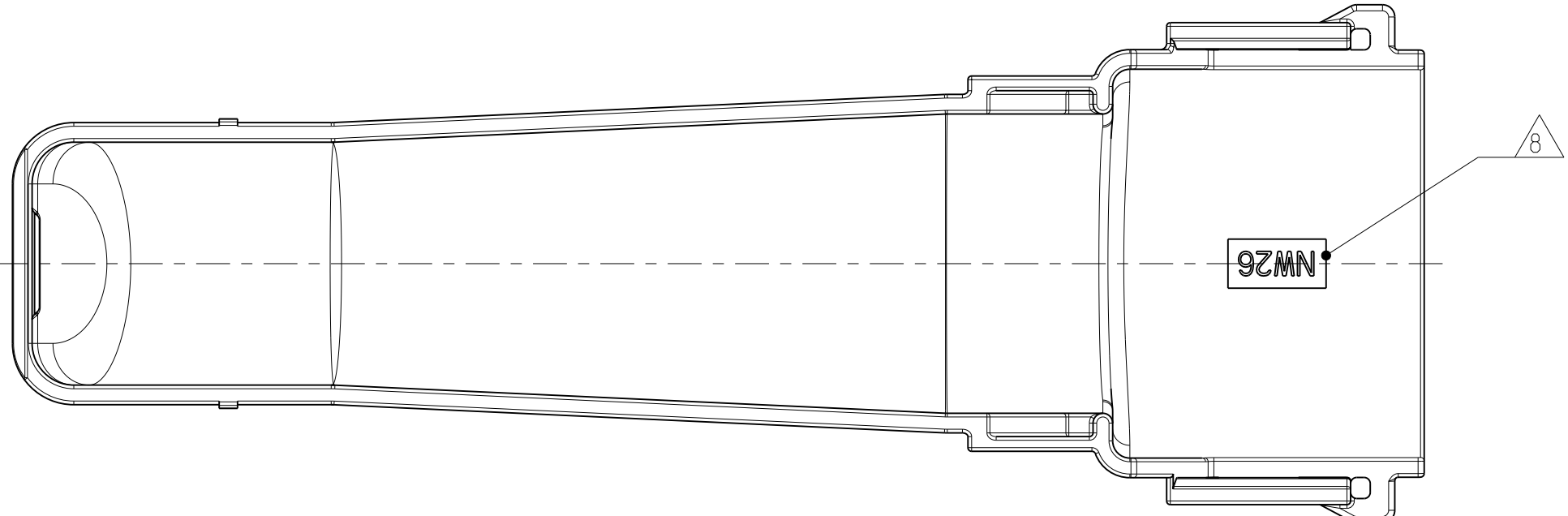

NOTES

- Bemerkungen
- 1 TE-LOGO AND TE-NUMBER  
TE-Logo und TE-Nummer
  - 2 PRODUCTION DATE  
Produktionsdatum
  - 3 MATERIAL MARKING ACC. TO VDA 260  
Werkstoffkennzeichnung nach VDA 260
  - 4 MOULD CAVITY MARKING  
Nestmarkierung
  - 5 REVISION STATUS OF THE MOULD  
Aenderungsstand des Werkzeugs
  - 6 BULK PACKAGING IN CARDBOARD-BOX  
Schuetftgut im Versandkarton
  - 7 SUITABLE FOR 92POS. AMP MCPI.5 HOUSING  
Passend zu 92pol. AMP MCPI.5 Gehaeuse  
TE-NO.: 1703998
  - 8 SUITABLE FOR CORRUGATED TUBE WITH  
NOMINAL WIDTH NW26  
Passend fuer Wellrohr Nennweite NW26
  - 9 WARPAGE UP TO -2MM FROM NOM. DIM. ALLOWED  
Verzug bis zu -2mm vom Nennmass erlaubt

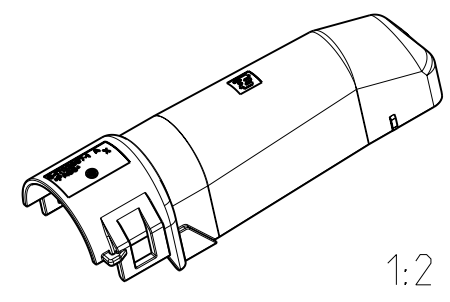
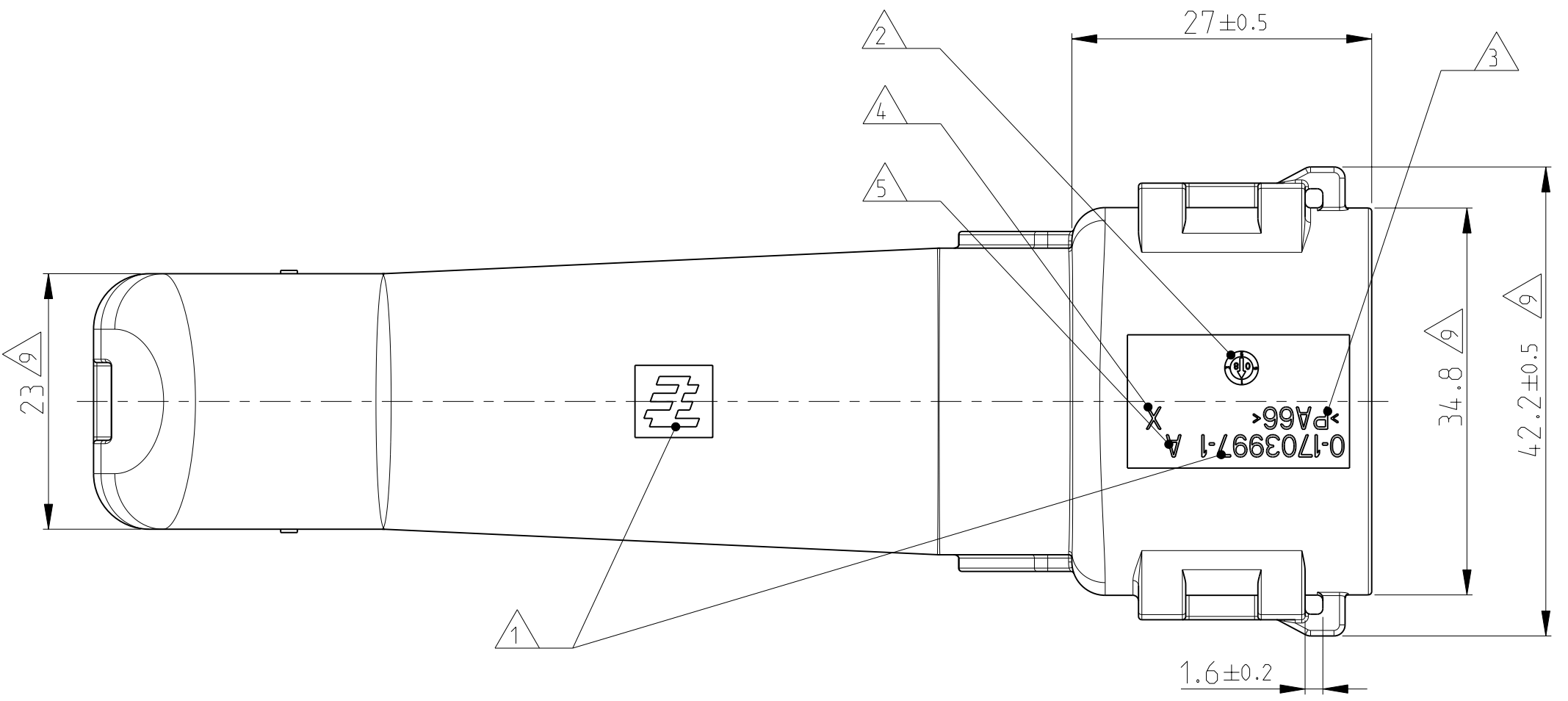

THIS DRAWING IS A CONTROLLED DOCUMENT FOR TYCO ELECTRONICS CORPORATION IT IS SUBJECT TO CHANGE AND THE CONTROLLING ENGINEERING ORGANIZATION SHOULD BE CONTACTED FOR THE LATEST REVISION. DIESES ZEICHNUNGSDOKUMENT WIRD DURCH AMP INCORPORATED KONTROLLIERT. AENDERUNGEN, DIE DEM TECHNISCHEN FORTSCHRITT DIENEN, SIND VORBEHALTEN. DEN JEWEILS LETZTGUELTIGEN AENDERUNGSSTAND ERFAHREN SIE AUF ANFRAGE.		DWN V.Deas 24FEB2009	Tyco Electronics Tyco Electronics AMP GmbH 64625 Bensheim (Germany)	
DIMENSIONS: MASSE IN HEITEN: mm		CHK J. Granzow 25FEB2009	NAME COVER, 90, DEGREE Kappe, 90 Grad, 92pol.	
TOLERANCES UNLESS OTHERWISE SPECIFIED: ALLGEMEINTOLERANZEN		APVD Ch. Fierwein 25FEB2009	SIZE A2	RESTRICTED TO NUR FÜR
0-PLC ± - ISO 8015 1-PLC ± - DIN 16901-140 2-PLC ± - 3-PLC ± - 4-PLC ± - ANGLES/WINKEL ± 1°		PRODUCT SPEC 108-94174	CAGE CODE 00779	REV A
MATERIAL PA66 BLACK / schwarz		APPLICATION SPEC 114-18963	DRAWING NO. 1703997	
FINISH/OBERFLAECHE/FARBE		WEIGHT 17.4g	SCALE MASSSTAB 2:1	
		CUSTOMER DRAWING	/KUNDENZEICHNUNG	
			SHEET BLATT 1	OF VON 1