



Chipsmall Limited consists of a professional team with an average of over 10 year of expertise in the distribution of electronic components. Based in Hongkong, we have already established firm and mutual-benefit business relationships with customers from,Europe,America and south Asia,supplying obsolete and hard-to-find components to meet their specific needs.

With the principle of “Quality Parts,Customers Priority,Honest Operation,and Considerate Service”,our business mainly focus on the distribution of electronic components. Line cards we deal with include Microchip,ALPS,ROHM,Xilinx,Pulse,ON,Everlight and Freescale. Main products comprise IC,Modules,Potentiometer,IC Socket,Relay,Connector.Our parts cover such applications as commercial,industrial, and automotives areas.

We are looking forward to setting up business relationship with you and hope to provide you with the best service and solution. Let us make a better world for our industry!



Contact us

Tel: +86-755-8981 8866 Fax: +86-755-8427 6832

Email & Skype: info@chipsmall.com Web: www.chipsmall.com

Address: A1208, Overseas Decoration Building, #122 Zhenhua RD., Futian, Shenzhen, China



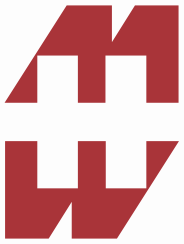

HAMMOND
MANUFACTURING®

www.hammondmfg.com

Plug-In Isolation Transformers (115VAC to 115VAC)

171E



Hammond Plug-In Isolation Transformers

Hammond isolation transformers provide complete circuit isolation to protect your sensitive electronics. 171E features an electrostatic shield between the primary and secondary which greatly attenuates surges and noise caused by power problems on the same circuit or by supply disruptions from utilities. Isolation transformers are an essential for laboratory test benches where line voltage is used.

For safety concerns, every 171E has been hi-pot tested to 2KV RMS, and features a 5 amp circuit breaker on the primary. The primary features a 5' cord with a standard NEMA 5-15P plug. The secondary is connected to a 1' cord with a standard NEMA 5-15R receptacle. All units carry the North American mark of safety C UL & UL listed (File # E211544).



Features

- Primary 115VAC, 50/60 Hz., Secondary 115VAC
- Provides complete circuit isolation.
- Faraday electrostatic shield between primary & secondary to greatly attenuate surges and noise.
- Hi-pot tested to 2 KV RMS.
- Circuit breaker in primary.
- Standard 3-wire, grounded plug & receptacle.
- Input (primary) connected to 5 foot long cord & standard North American plug (NEMA 5-15P).
- Output (secondary) connected to 1 foot long "pig tail" cord, 3-wire, standard North American grounded receptacle (NEMA 5-15R).
- North American Mark of Safety - C UL & UL listed (File #E211544)
- Indoor use only
- **Remember** - These units do NOT convert line frequency



Plug-In Isolation Transformers (115VAC to 115VAC)

171E

Electrical Specifications:

Primary Voltage	115VAC
Secondary Voltage	115VAC
Frequency	50 / 60 Hz
Capacity VA	500
Leakage Current	< 100 μ A
Full Load Efficiency	93% (typical)
Full Load Total Harmonic Distortion	0.18% (typical)
Surge/ Noise Suppression	-37.18 dB (typical)
Capacitance Between Windings @ 1 kHz	20 pF (typical)
Circuit Breaker (Amps)	5A on primary

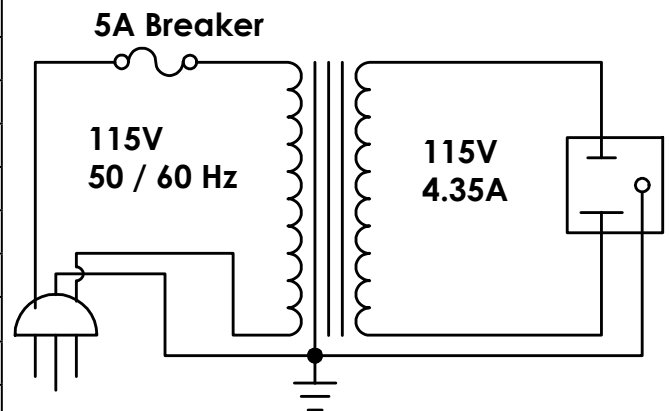

Dimensions

A	3.8" / 97 mm
B	7.06" / 179 mm
C	4.68" / 119 mm
D	3" / 76 mm
E	5.38" / 137 mm
Weight	14 lbs / 6.35 kg
Cord Length (Primary)	5ft / 1.52m
Cord Length (Secondary)	1ft / 0.30m
Plug on Primary	NEMA 5-15P
Receptacle on Secondary	NEMA 5-15R

