



Chipsmall Limited consists of a professional team with an average of over 10 year of expertise in the distribution of electronic components. Based in Hongkong, we have already established firm and mutual-benefit business relationships with customers from,Europe,America and south Asia,supplying obsolete and hard-to-find components to meet their specific needs.

With the principle of “Quality Parts,Customers Priority,Honest Operation,and Considerate Service”,our business mainly focus on the distribution of electronic components. Line cards we deal with include Microchip,ALPS,ROHM,Xilinx,Pulse,ON,Everlight and Freescale. Main products comprise IC,Modules,Potentiometer,IC Socket,Relay,Connector.Our parts cover such applications as commercial,industrial, and automotives areas.

We are looking forward to setting up business relationship with you and hope to provide you with the best service and solution. Let us make a better world for our industry!



Contact us

Tel: +86-755-8981 8866 Fax: +86-755-8427 6832

Email & Skype: info@chipsmall.com Web: www.chipsmall.com

Address: A1208, Overseas Decoration Building, #122 Zhenhua RD., Futian, Shenzhen, China



REV.	DATE	ECR NO.	DESCRIPTION
NC	03/16/09	XXXXXX	INITIAL RELEASE
A	11/05/13	2548	UPDATE DRAWING FORMAT, UPDATE VENDOR DRAWING

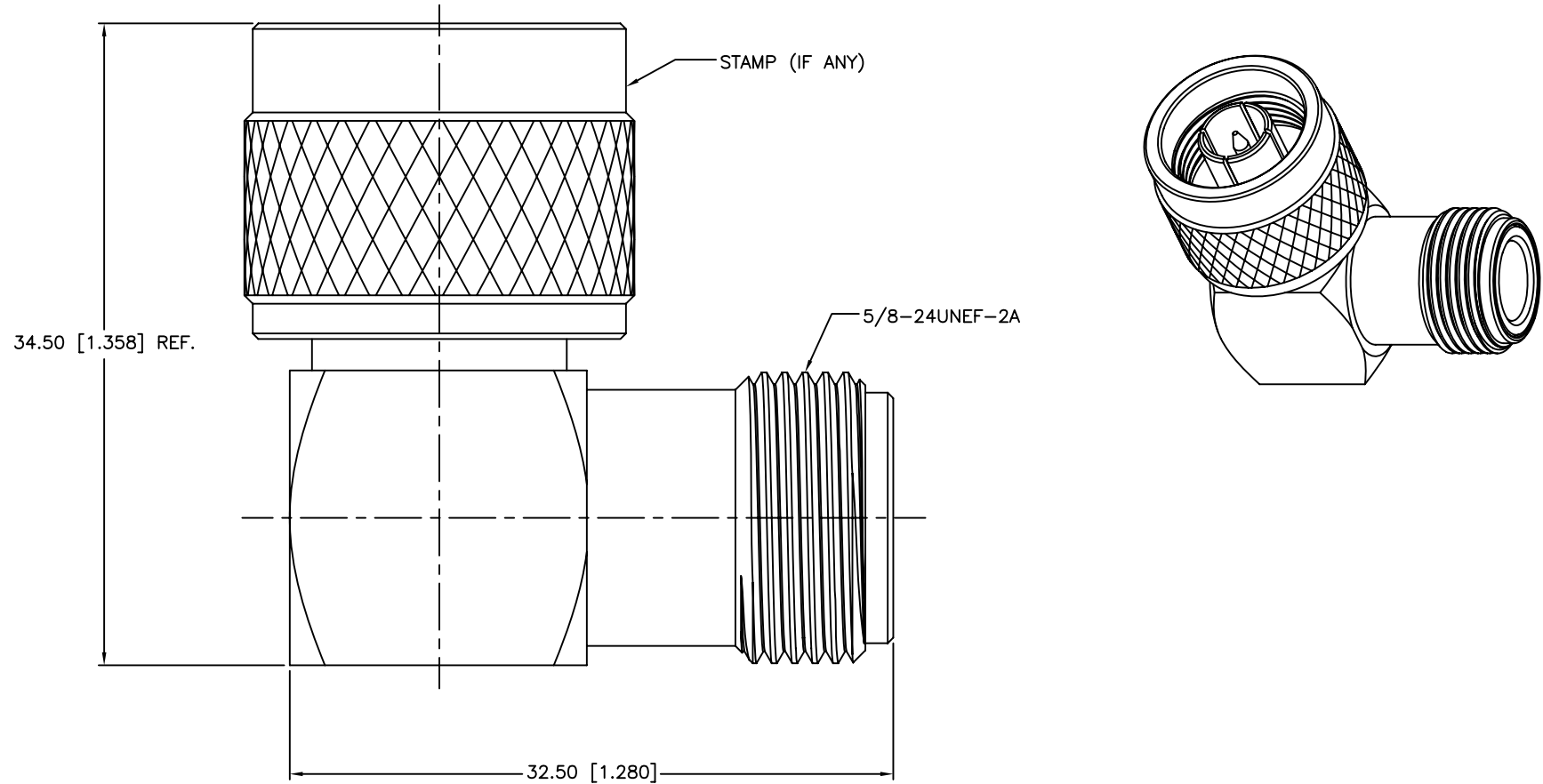

1. IMPEDANCE: 50 OHM
2. FREQUENCY RANGE: 0-11 GHZ
3. DIELECTRIC WITHSTANDING VOLTAGE: 2500 VRMS, MIN.
4. DURABILITY: 500 CYCLES MIN.
5. TEMPERATURE RANGE: -65°C TO +165°C

9	SHELL	BRASS	NEXCOTE	1	<small>UNLESS OTHERWISE SPECIFIED DIMENSIONS ARE IN MILLIMETERS. DIMENSIONS IN [] ARE IN INCHES AND FOR CUSTOMER REFERENCE ONLY. UNLESS OTHERWISE SPECIFIED</small> <small>TOLERANCES FOR MILLIMETERS ARE:</small> <0.5 ± 0.05mm 0.5 - 6mm ± 0.10mm 6 - 30mm ± 0.20mm 30 - 120mm ± 0.30mm ANGLES ± 1° <small>UNLESS OTHERWISE SPECIFIED TOLERANCES FOR INCHES ARE:</small> <.020 ± 0.002" .020 - .236 ± 0.004" .236 - 1.180 ± 0.007" 1.180 - 4.724 ± 0.012" ANGLES ± 1°	APPROVALS	DATE	<h1>Amphenol Connex</h1>								
8	GASKET	SILICONE RUBBER	RED	1		DRAWN	M.ZHANG				11/05/13					
7	RETAINING RING	SUS 304	NATURAL	1		CHECKED			PART DESCRIPTION N MALE TO FEMALE RIGHT ANGLE ADAPTER							
6	INNER BODY	BRASS	NEXCOTE	1		ISSUED										
5	INSULATOR	PTFE	NATURAL	1		SHEET	1 OF 1		PART NO. 172193							
4	CONTACT BODY	BRASS	NEXCOTE	1		CAD FILE	C:/CONNEX/172193.DWG					DWG. NO.	172193.DWG	REV.	A	SIZE
3	INSULATOR	PTFE	NATURAL	1												
2	CONTACT PIN	PHOSPHOR BRONZE	GOLD	1												
1	HOUSING WITH BODY	BRASS	NEXCOTE	1												
	DESCRIPTION	MATERIAL	FINISH	QTY		DO NOT SCALE DRAWING										