



Chipsmall Limited consists of a professional team with an average of over 10 year of expertise in the distribution of electronic components. Based in Hongkong, we have already established firm and mutual-benefit business relationships with customers from,Europe,America and south Asia,supplying obsolete and hard-to-find components to meet their specific needs.

With the principle of "Quality Parts,Customers Priority,Honest Operation,and Considerate Service",our business mainly focus on the distribution of electronic components. Line cards we deal with include Microchip,ALPS,ROHM,Xilinx,Pulse,ON,Everlight and Freescale. Main products comprise IC,Modules,Potentiometer,IC Socket,Relay,Connector.Our parts cover such applications as commercial,industrial, and automotives areas.

We are looking forward to setting up business relationship with you and hope to provide you with the best service and solution. Let us make a better world for our industry!



Contact us

Tel: +86-755-8981 8866 Fax: +86-755-8427 6832

Email & Skype: info@chipsmall.com Web: www.chipsmall.com

Address: A1208, Overseas Decoration Building, #122 Zhenhua RD., Futian, Shenzhen, China



NUMBER C-1734215

3RD ANGLE PROJECTION

METRIC

THIS INFORMATION IS CONFIDENTIAL AND IS DISCLOSED TO YOU ON CONDITION THAT YOU WILL NOT DISCLOSE IT TO ANY OTHER PERSONNEL WITHOUT WRITTEN AUTHORIZATION FROM AMP (TWAIN) LTD. DIMENSION IN MILLIMETERS. DO NOT SCALE PRINT.

- NOTES :
- MATERIAL :
 - HOUSING : THERMOPLASTIC(PA46), w/ 30% G/F, UL 94 V-0, COLOR: SEE TABLE.
 - EXTRACTOR : THERMOPLASTIC, w/ 30% G/F, COLOR: WHITE; Δ BLUE(2945C)
 - CONTACTS : PHOSPHOR BRONZE
 - BOARDLOCK : BRASS
 - FINISH:
 - CONTACT: GOLD PLATING (SEE TABLE) ON CONTACT AREA, 100 μ MIN. MATTE TIN PLATING ON SOLDER TAIL AREA, 50 μ MIN. NICKEL UNDERPLATING OVERALL
 - BOARDLOCK: 100 μ MIN. MATTE TIN PLATING, 50 μ MIN. NICKEL UNDERPLATING OVERALL
 - WAVE SOLDER CAPABLE TO 265°C PER TYCO SPEC. 109-202, CONDITION B.

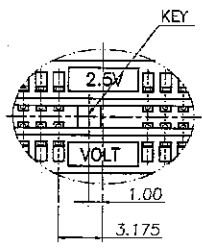
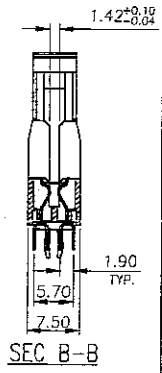
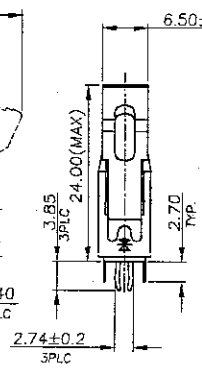
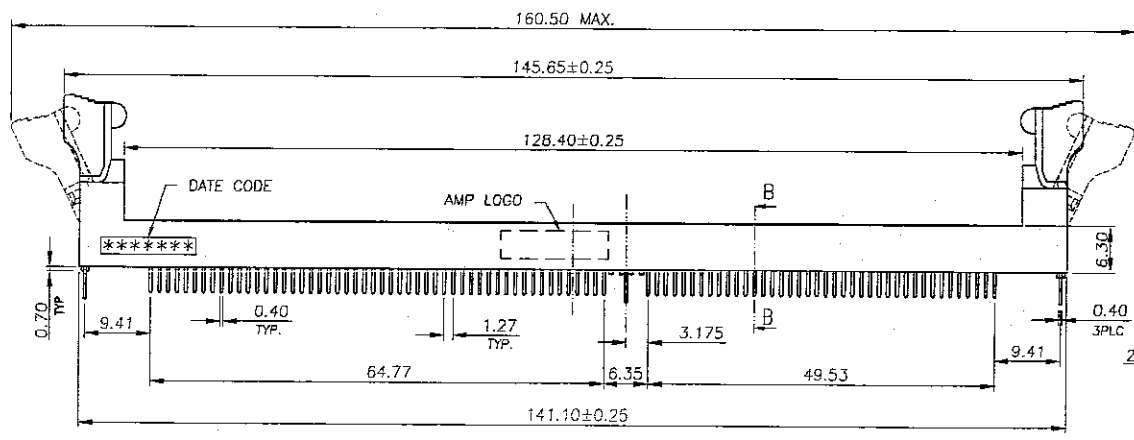
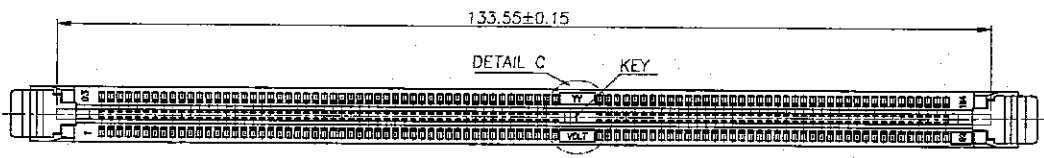

DETAIL C (2.5V)
SCALE 2:1

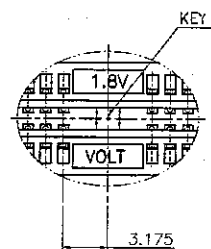

DETAIL C (1.8V)
SCALE 2:1

PHOSPHOR BRONZE VERSION OF CONTACT MATERIAL

HSG COLOR	VOLTAGE	GOLD FLASH	PART NUMBER
APPLE GREEN 382U	2.5V DC VIEW B	GOLD FLASH	9-1734215-3
	1.8V DC VIEW A	GOLD FLASH	9-1734215-1
YELLOW 115C	2.5V DC VIEW B	GOLD FLASH	8-1734215-3
	1.8V DC VIEW A	GOLD FLASH	8-1734215-1
BLUE GREEN 338U	2.5V DC VIEW B	GOLD FLASH	5-1734215-3
	1.8V DC VIEW A	GOLD FLASH	5-1734215-1
PURPLE 2726U	2.5V DC VIEW B	GOLD FLASH	4-1734215-3
	1.8V DC VIEW A	GOLD FLASH	4-1734215-1
RED 193C	2.5V DC VIEW B	15 μ	2-1734215-4
	1.8V DC VIEW A	GOLD FLASH	2-1734215-3
		GOLD FLASH	2-1734215-1
BLUE 2945C	2.5V DC VIEW B	15 μ	1-1734215-4
	1.8V DC VIEW A	GOLD FLASH	1-1734215-3
		GOLD FLASH	1-1734215-1
BLACK	2.5V DC VIEW B	GOLD FLASH	Δ 1734215-5
	1.8V DC VIEW A	GOLD FLASH	1734215-4
		GOLD FLASH	1734215-3
	2.5V DC VIEW B	15 μ	1734215-5
	1.8V DC VIEW A	15 μ	1734215-2
	GOLD FLASH		1734215-1

TOLERANCES UNLESS OTHERWISE SPECIFIED:	DWN	S. HOU 22-MAY-2005	TYCO HOLDINGS (BERMUDA) VII LTD. TAIWAN BRANCH
0 PLC ±	CHK	W.J. KE	NAME
1 PLC ±0.3		22-MAY-2005	
2 PLC ±0.2			
3 PLC ±			
ANGLES ±0.5°			
MATERIAL	APVD	W.J. KE	SOCKET ASSEMBLY, DIMM 2P LOW INSERTION FORCE, 184 POSITION
SEE NOTE	PRODUCT SPEC	22-MAY-2005	109-57401
	QUALIFICATION TEST REPORT		501-57433
	WEIGHT		8.9 GRAM

A	REVISED	ECR-06-010456	SH WK	22MAY 2005	FINISH
O	FIRST RELEASED	FZ00-0010-05	SH WK	17JAN 2005	SEE NOTE
LTR	REVISION RECORD	ECN	DR CHK	DATE	

NUMBER C-1734215

3RD ANGLE PROJECTION

METRIC

THIS INFORMATION IS CONFIDENTIAL AND IS DISCLOSED TO YOU ON CONDITION THAT YOU WILL NOT REPRODUCE OR DISSEMINATE IT WITHOUT WRITTEN AUTHORIZATION FROM AMP (TAINAN) LTD. DIMENSION IN MILLIMETERS. DO NOT SCALE PRINT.

- NOTES :
- MATERIAL :
 - HOUSING : THERMOPLASTIC(PA46) W/ 30% G/F, UL 94 V-0, COLOR: SEE TABLE.
 - EXTRACTOR : THERMOPLASTIC, W/ 30% G/F, COLOR: WHITE.
 - CONTACTS : BRASS
 - BOARDLOCK : BRASS
 - FINISH:
 - CONTACT:
 - GOLD PLATING (SEE TABLE) ON CONTACT AREA
 - 100μ" MIN. MATTE TIN PLATING ON SOLDER TAIL AREA,
 - 50μ" MIN. NICKEL UNDERPLATING OVERALL
 - BOARDLOCK:
 - 100μ" MIN. MATTE TIN PLATING
 - 50μ" MIN. NICKEL UNDERPLATING OVERALL,
 - WAVE SOLDER CAPABLE TO 265°C PER TYCO SPEC. 109-202, CONDITION B.

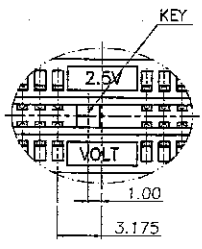
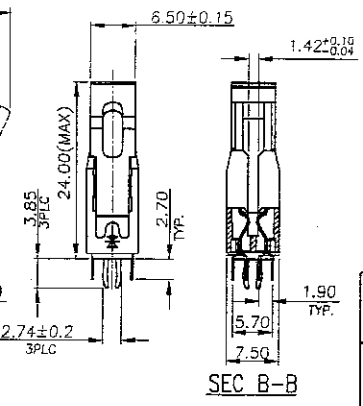
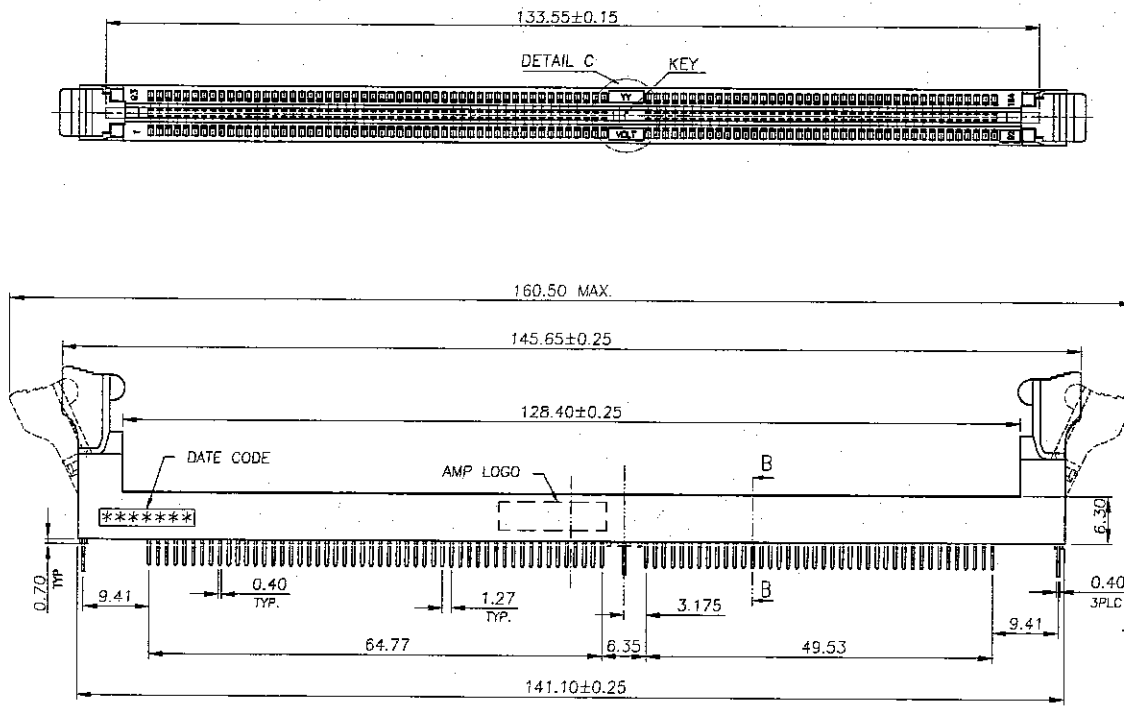

DETAIL C (2.5V)
SCALE 2:1

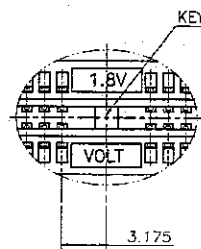

DETAIL C (1.8V)
SCALE 2:1

BRASS VERSION OF CONTACT MATERIAL

HSG COLOR	VOLTAGE	GOLD FLASH	PART NUMBER
APPLE GREEN 382U	2.5V DC VIEW B	GOLD FLASH	7-1734215-3
	1.8V DC VIEW A	GOLD FLASH	7-1734215-1
YELLOW 115C	2.5V DC VIEW B	GOLD FLASH	6-1734215-3
	1.8V DC VIEW A	GOLD FLASH	6-1734215-1
PURPLE 2726U	2.5V DC VIEW B	GOLD FLASH	4-1734215-7
	1.8V DC VIEW A	GOLD FLASH	4-1734215-5
BLACK	2.5V DC VIEW B	15μ"	3-1734215-4
		GOLD FLASH	3-1734215-3
	1.8V DC VIEW A	15μ"	3-1734215-2
RED 193C	2.5V DC VIEW B	GOLD FLASH	2-1734215-7
	1.8V DC VIEW A	GOLD FLASH	2-1734215-5
BLUE 301C	2.5V DC VIEW B	GOLD FLASH	1-1734215-7
	1.8V DC VIEW A	GOLD FLASH	1-1734215-5

TOLERANCES UNLESS OTHERWISE SPECIFIED:	DWN	S. HOU	TYCO	TYCO HOLDINGS (BERMUDA)
0 PLC ±		22-MAY-2006	Electronics	VII LTD. TAIWAN BRANCH
1 PLC ±0.3	CHK	W.J. KE	NAME	
2 PLC ±0.2		22-MAY-2006		
3 PLC ±				
ANGLES ±0.5°				
MATERIAL	APVD	W.J. KE	SOCKET ASSEMBLY, DIMM 2P	
SEE NOTE		22-MAY-2006	LOW INSERTION FORCE, 184	
	PRODUCT SPEC		POSITION	
	---		LOC	SIZE
FINISH	QUALIFICATION TEST REPORT		DW	DRAWING NO
SEE NOTE	---		A	C-1734215
	WEIGHT		SCALE	REV
	5.9 GRAM		---	A
			SHEET	
				2 OF 4

SEE SHEET 1	ECN	DR	DATE
LTR	REVISION RECORD	CHK	

CUSTOMER DRAWING

NUMBER
C-1734215

3RD ANGLE PROJECTION

METRIC

THIS INFORMATION IS CONFIDENTIAL AND IS RELEASED TO YOU ON CONDITION THAT NO FURTHER DISCLOSURE IS MADE BY YOU TO OTHER THAN AMP PERSONNEL WITHOUT WRITTEN AUTHORIZATION FROM AMP (TAIWAN) LTD. DIMENSIONS IN MILLIMETERS. DO NOT SCALE PRINT.

PRINT
DW

NOTE:
JEDEC SPEC MO-206 FOR COMPLETE MODULE

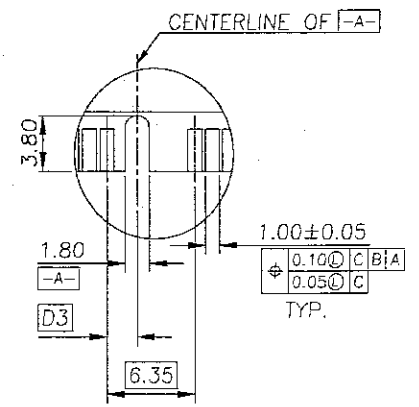
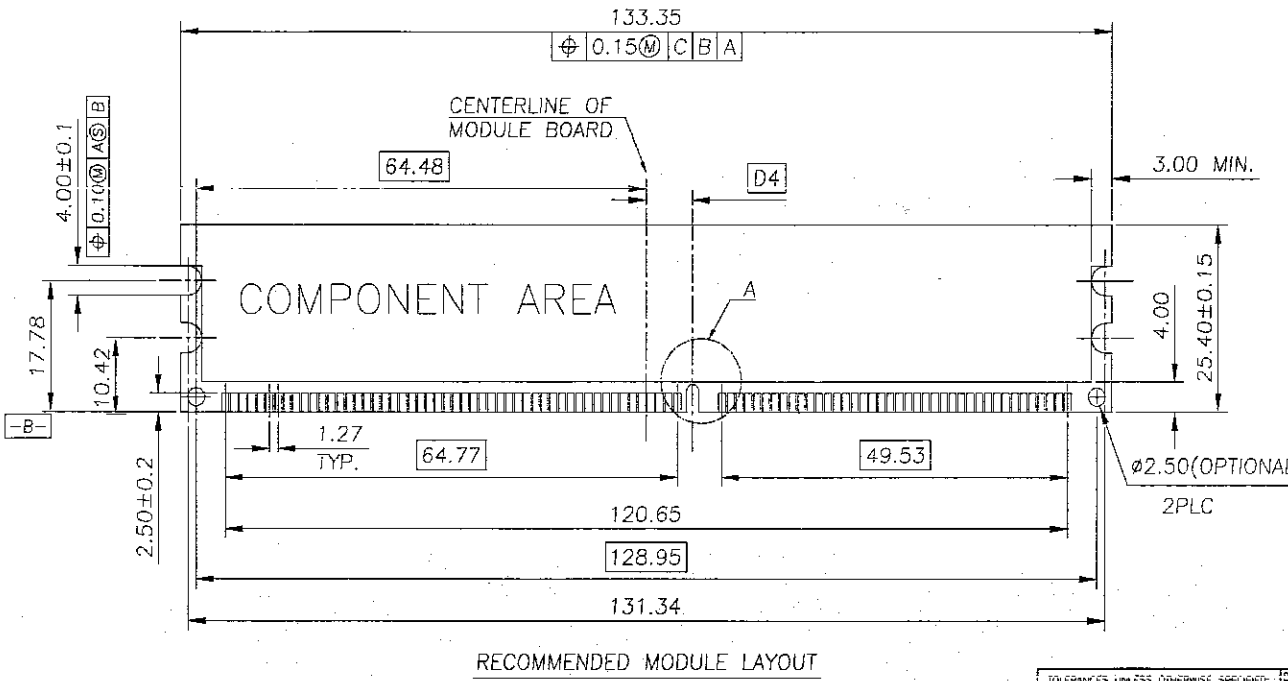
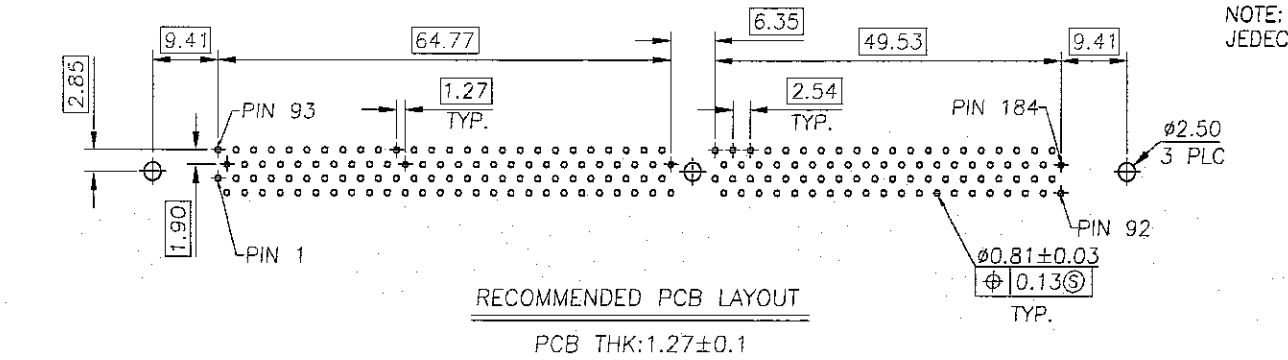

7.62	3.175	1.8V
6.62	2.175	2.5V
D4	D3	VOLTAGE
DIMENSION		

TOLERANCES UNLESS OTHERWISE SPECIFIED: 0 PLC ±0.3 1 PLC ±0.2 2 PLC ±0.2 3 PLC ±0.2 ANGLES ±3°	CHK W.J. KE 22-MAY-2008	S. HOU 22-MAY-2008	tyco Electronics TYCO HOLDINGS (BERMUDA) VII LTD. TAIWAN BRANCH
MATERIAL	APVD W.J. KE 22-MAY-2008	PRODUCT SPEC	NAME SOCKET ASSEMBLY, DIMM 2P LOW INSERTION FORCE, 184 POSITION
FINISH	APPLICATION SPEC	WEIGHT	LOC SIZE DRAWING NO DW A3 C-1734215
SEE SHEET 1	REVISION RECORD	ECN	SCALE SHEET 3 OF 4

LTR	REVISION RECORD	ECN	DWN	CHK	DATE
-----	-----------------	-----	-----	-----	------

NUMBER C-1734215

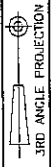

METRIC

THIS INFORMATION IS CONFIDENTIAL AND IS DISCLOSED TO YOU ON A CONDITION THAT YOU WILL NOT DISCLOSE IT TO ANY OTHER PERSONS WITHOUT THE WRITTEN AUTHORIZATION FROM AMP (TAIWAN) LTD. DIMENSION IN MILLIMETERS. DO NOT SCALE PRINT.

PRINT DW

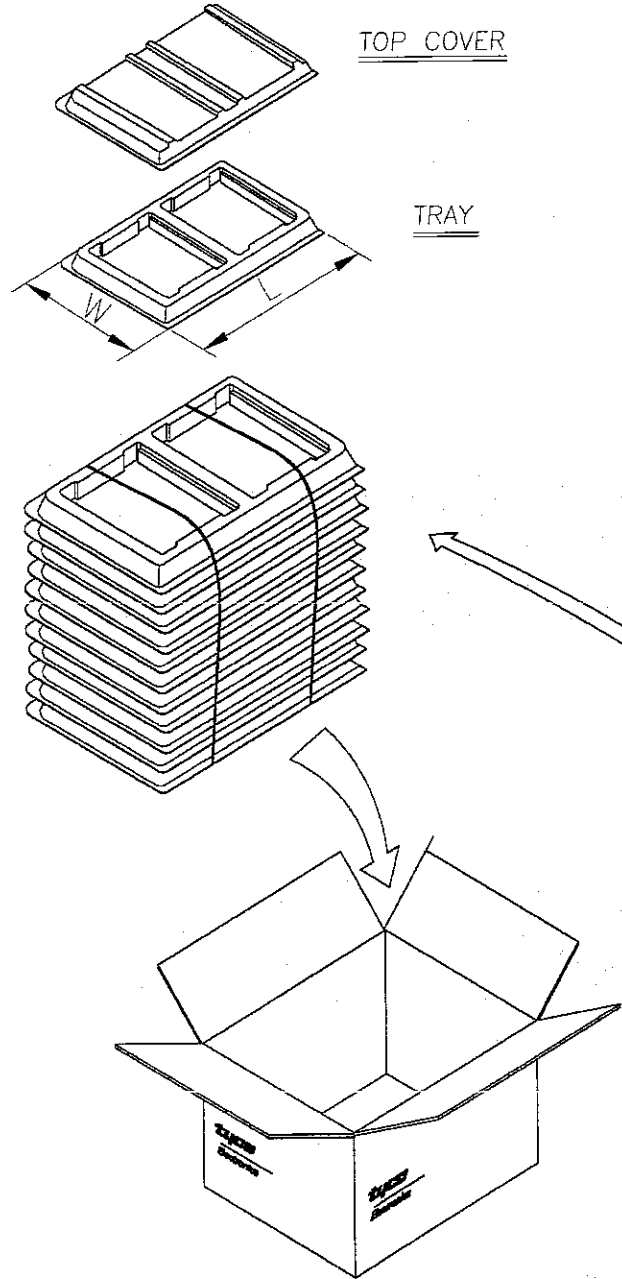

- NOTES :
1. MATERIAL :
 - 1.1 TRAY : PVC
 - 1.2 SHIPPING CARTON : CORRUGATED FIBERBOARD
 2. DIMENSION :
 - 2.1 TRAY : L=363, W=255, H=33
 - 2.1 SHIPPING CARTON : L=380, W=270, H=340
 3. QUANTITY :
 - 3.1 PRIMARY PACKING: 50 PCS/TRAY
 - 3.2 SECONDARY PACKING: 10 TRAY/CARTON(500PCS)
 4. WEIGHT :
 - 4.1 NET WEIGHT : 4.45Kg
 - 4.2 GROSS WEIGHT : 6.478Kg

SEE SHEET 1.	ECN	DR	CHK	DATE
LTR	REVISION RECORD			

TOLERANCES UNLESS OTHERWISE SPECIFIED:		DWN	S. HOU	tyco TYCO HOLDINGS (BERMUDA) VII LTD. TAIWAN BRANCH
0 PLC	#	22-MAY-2006	W.J. KE	
1 PLC	#	CHK	W.J. KE	NAME Electronics
2 PLC	#	22-MAY-2006	W.J. KE	
3 PLC	#			SOCKET ASSEMBLY, DIMM 2P LOW INSERTION FORCE, 184 POSITION
ANGLES	#			
MATERIAL	SEE NOTE	APVD	W.J. KE	LOC SIZE DRAWING NO DW A3 C-1734215
		PRODUCT SPEC	22-MAY-2006	
FINISH		APPLICATION SPEC		SCALE
		WEIGHT		SHEET
				4 OF 4

8 7 6 5 4 3 2 1 CUSTOMER DRAWING