



Chipsmall Limited consists of a professional team with an average of over 10 year of expertise in the distribution of electronic components. Based in Hongkong, we have already established firm and mutual-benefit business relationships with customers from,Europe,America and south Asia,supplying obsolete and hard-to-find components to meet their specific needs.

With the principle of “Quality Parts,Customers Priority,Honest Operation,and Considerate Service”,our business mainly focus on the distribution of electronic components. Line cards we deal with include Microchip,ALPS,ROHM,Xilinx,Pulse,ON,Everlight and Freescale. Main products comprise IC,Modules,Potentiometer,IC Socket,Relay,Connector.Our parts cover such applications as commercial,industrial, and automotives areas.

We are looking forward to setting up business relationship with you and hope to provide you with the best service and solution. Let us make a better world for our industry!



## Contact us

Tel: +86-755-8981 8866 Fax: +86-755-8427 6832

Email & Skype: info@chipsmall.com Web: www.chipsmall.com

Address: A1208, Overseas Decoration Building, #122 Zhenhua RD., Futian, Shenzhen, China



THIS DRAWING IS UNPUBLISHED. RELEASED FOR PUBLICATION 20  
 © COPYRIGHT 20 BY TYCO ELECTRONICS CORPORATION. ALL RIGHTS RESERVED.

LOC	DIST	REVISIONS					
DF	A5	P	LTR	DESCRIPTION	DATE	DWN	APVD
		1		PROPOSED	24OCT05	BH	JPM

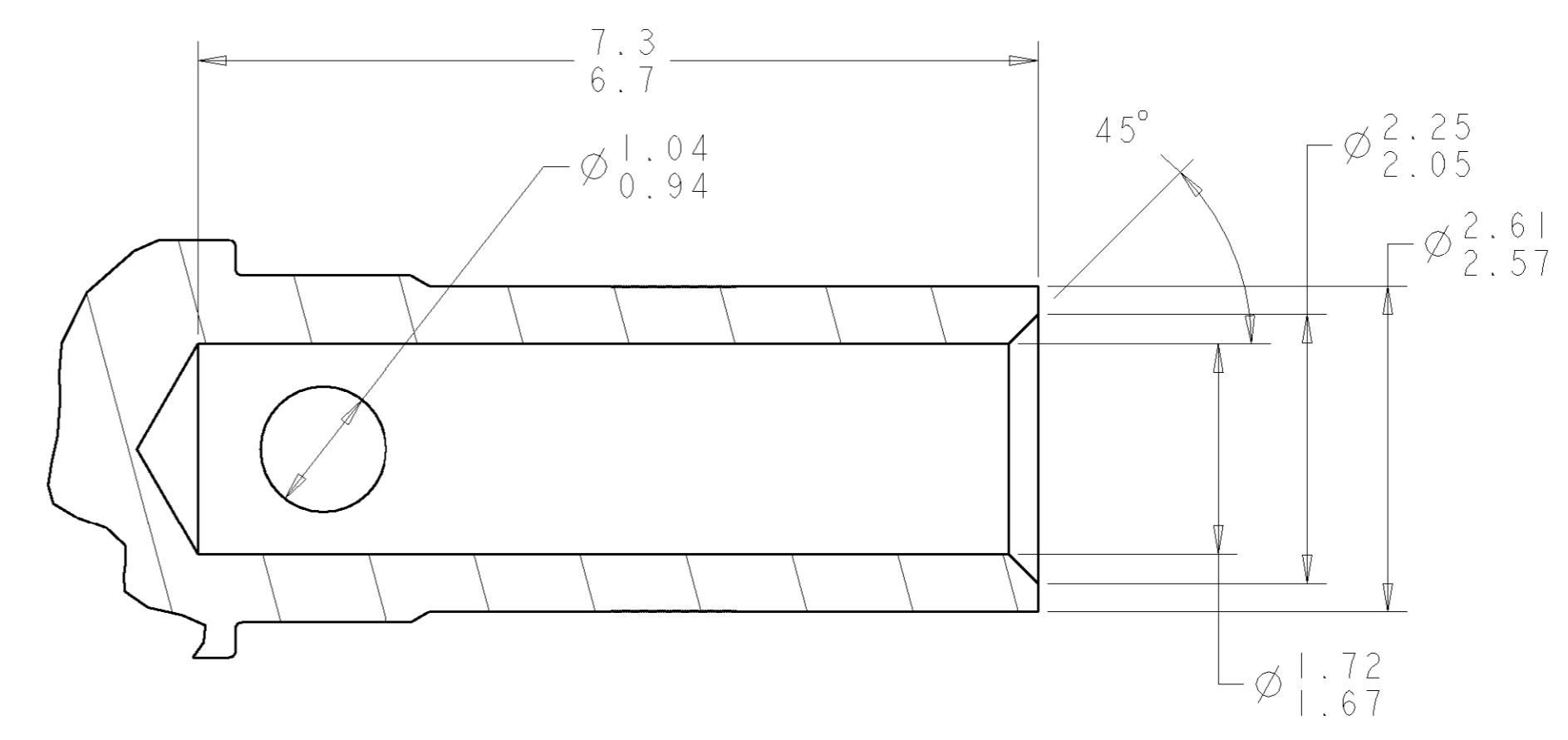
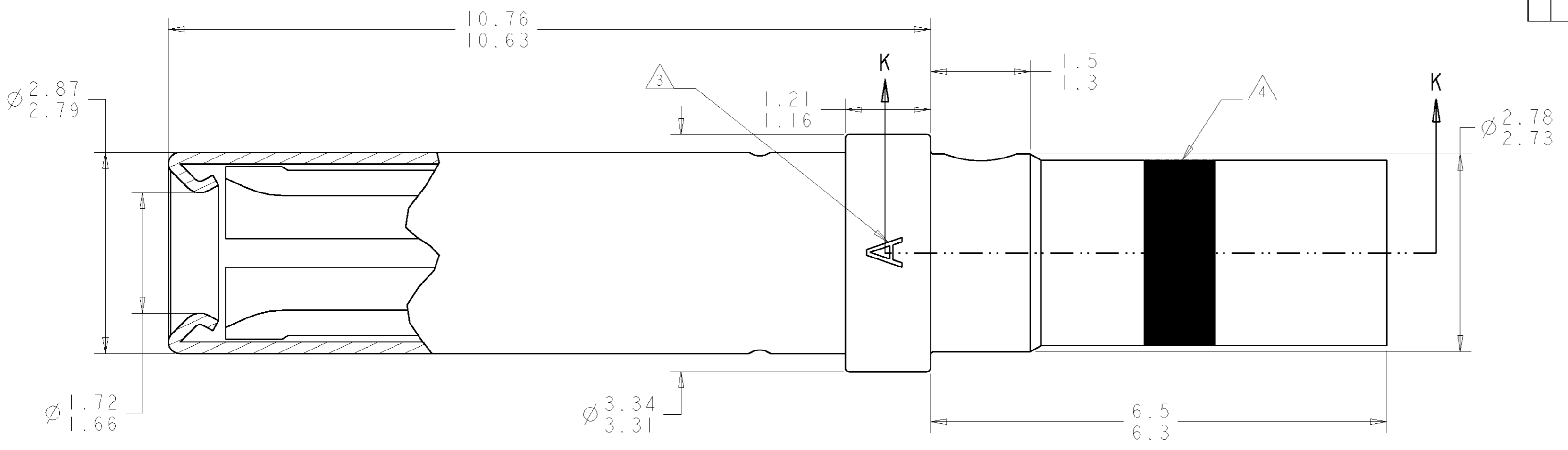

- 1 CONTACT: COPPER ALLOY PER ASTM B196  
SLEEVE: STAINLESS STEEL PER AISI 305
- 2 CONTACT: 1.27µm MIN GOLD PER ASTM B488 OVER 2.54µm  
MIN NICKEL PER QQ-N-290 ON ENTIRE STOCK.  
SLEEVE: PASSIVATED
- 3 OPTIONAL ALTERNATE MARKING: LETTER "S"
- 4 BLUE COLOR BAND
- 5. APPLICABLE WIRE SIZE: 16-18-20 AWG  
WIRE INSULATION DIAMETER: 2.6 mm MAX  
INSULATION STRIP LENGTH: 6.0-6.5mm
- 6. APPLICATION TOOLING:  
CRIMPING TOOL: TYCO PART NUMBER 601967-1 (M22520/1-01)  
POSITIONER: TYCO PART NUMBER 601967-2 (M22520/1-02)  
SELECTOR POSITION: AWG 16: 6  
AWG 18: 5  
AWG 20: 4  
CONTACT INSERTION/EXTRACTION TOOL: 91066-3 (M81969/1-03)
- 7. THIS PRODUCT IS SOLD BY TYCO ELECTRONICS UNDER A LICENSE FROM RADIAL SA.

SECTION K-K

1738014-1  
PART NUMBER

THIS DRAWING IS A CONTROLLED DOCUMENT FOR TYCO ELECTRONICS CORPORATION IT IS SUBJECT TO CHANGE AND THE CONTROLLING ENGINEERING ORGANIZATION SHOULD BE CONTACTED FOR THE LATEST REVISION.		DWN BH	24OCT2005	Tyco Electronics Harrisburg, PA 17105-3608	
DIMENSIONS: mm		CHK JPM	24OCT2005		
TOLERANCES UNLESS OTHERWISE SPECIFIED: 0 PLC ± 1 PLC ±0.1 2 PLC ±0.05 3 PLC ± 4 PLC ± ANGLES ± FINISH		APVD JPM	24OCT2005	NAME SOCKET CONTACT ASSEMBLY, SIZE 16, GPR	
MATERIAL		PRODUCT SPEC	-	SIZE	A200779
1 - 2 -		APPLICATION SPEC	-	CAGE CODE	C-1738014
		WEIGHT	-	DRAWING NO	1738014
		CUSTOMER DRAWING	-	RESTRICTED TO	-
		SCALE	20:1	SHEET	OF