



Chipsmall Limited consists of a professional team with an average of over 10 year of expertise in the distribution of electronic components. Based in Hongkong, we have already established firm and mutual-benefit business relationships with customers from,Europe,America and south Asia,supplying obsolete and hard-to-find components to meet their specific needs.

With the principle of “Quality Parts,Customers Priority,Honest Operation,and Considerate Service”,our business mainly focus on the distribution of electronic components. Line cards we deal with include Microchip,ALPS,ROHM,Xilinx,Pulse,ON,Everlight and Freescale. Main products comprise IC,Modules,Potentiometer,IC Socket,Relay,Connector.Our parts cover such applications as commercial,industrial, and automotives areas.

We are looking forward to setting up business relationship with you and hope to provide you with the best service and solution. Let us make a better world for our industry!



## Contact us

Tel: +86-755-8981 8866 Fax: +86-755-8427 6832

Email & Skype: info@chipsmall.com Web: www.chipsmall.com

Address: A1208, Overseas Decoration Building, #122 Zhenhua RD., Futian, Shenzhen, China



THIS DRAWING IS UNPUBLISHED. RELEASED FOR PUBLICATION 20  
 © COPYRIGHT 20 BY TYCO ELECTRONICS CORPORATION. ALL RIGHTS RESERVED.

REVISIONS							
LOC	DIST	P	LTR	DESCRIPTION	DATE	DWN	APVD
-	-	A		RELEASED PER ECO-09-013817	08JUL2009	RCF	JM

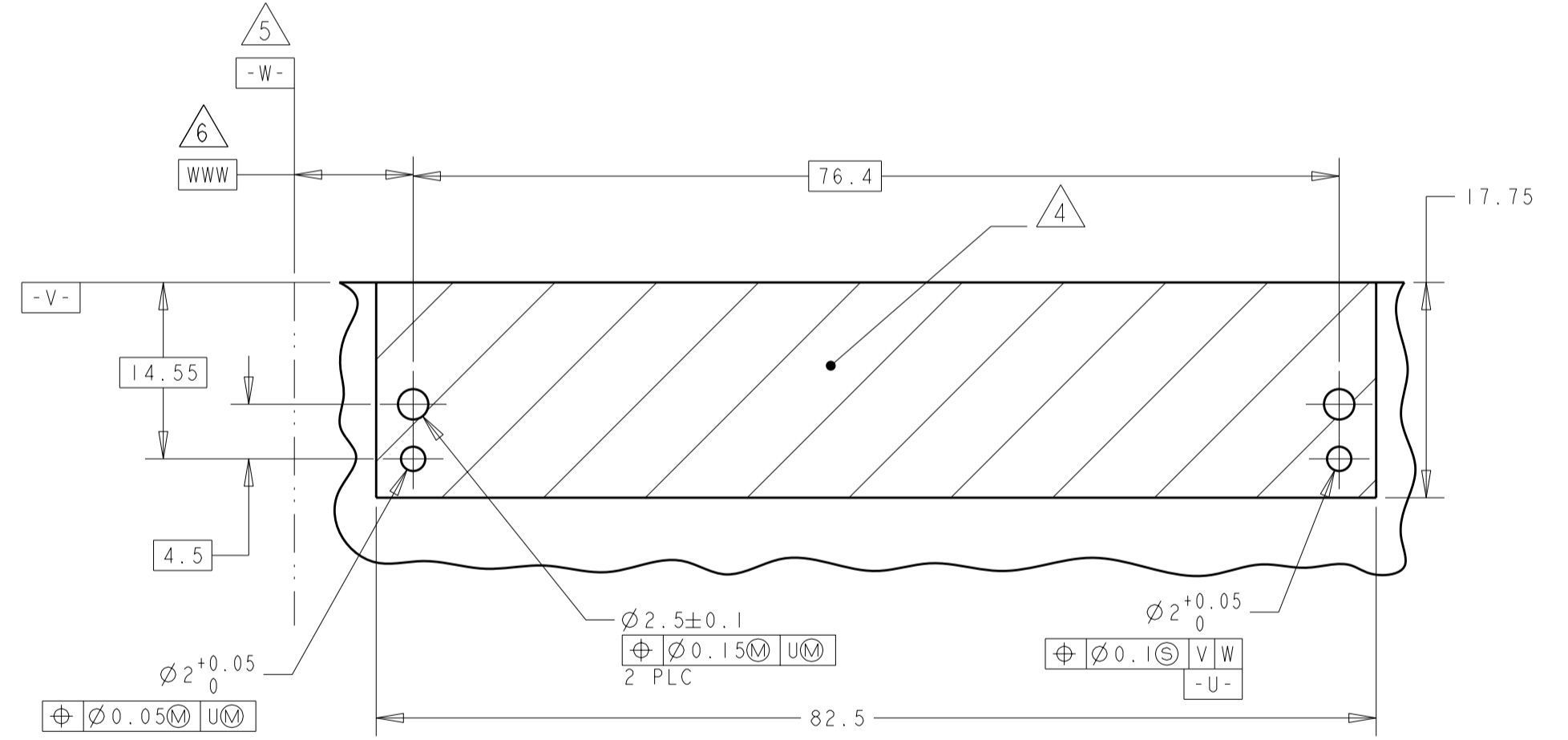
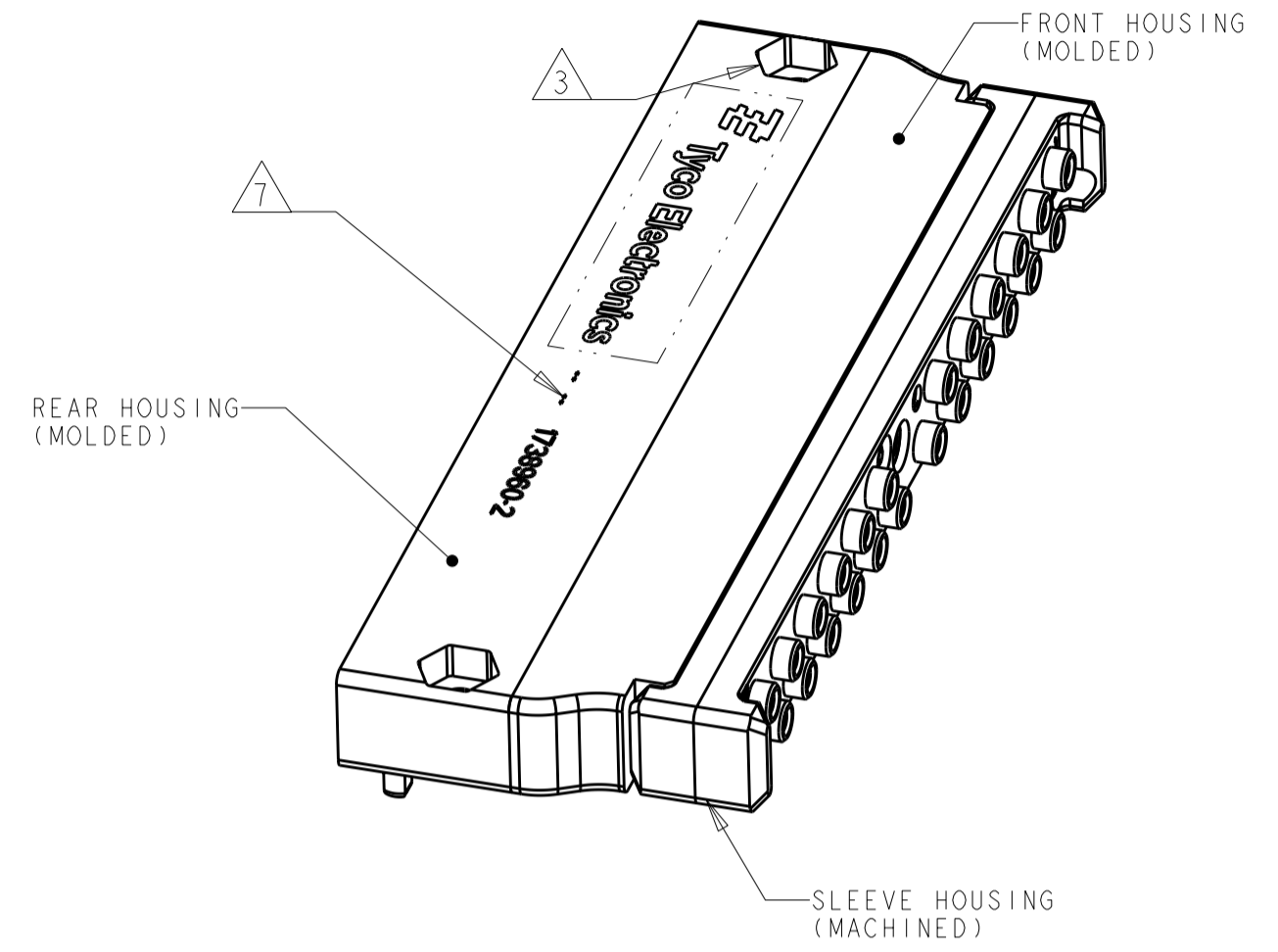
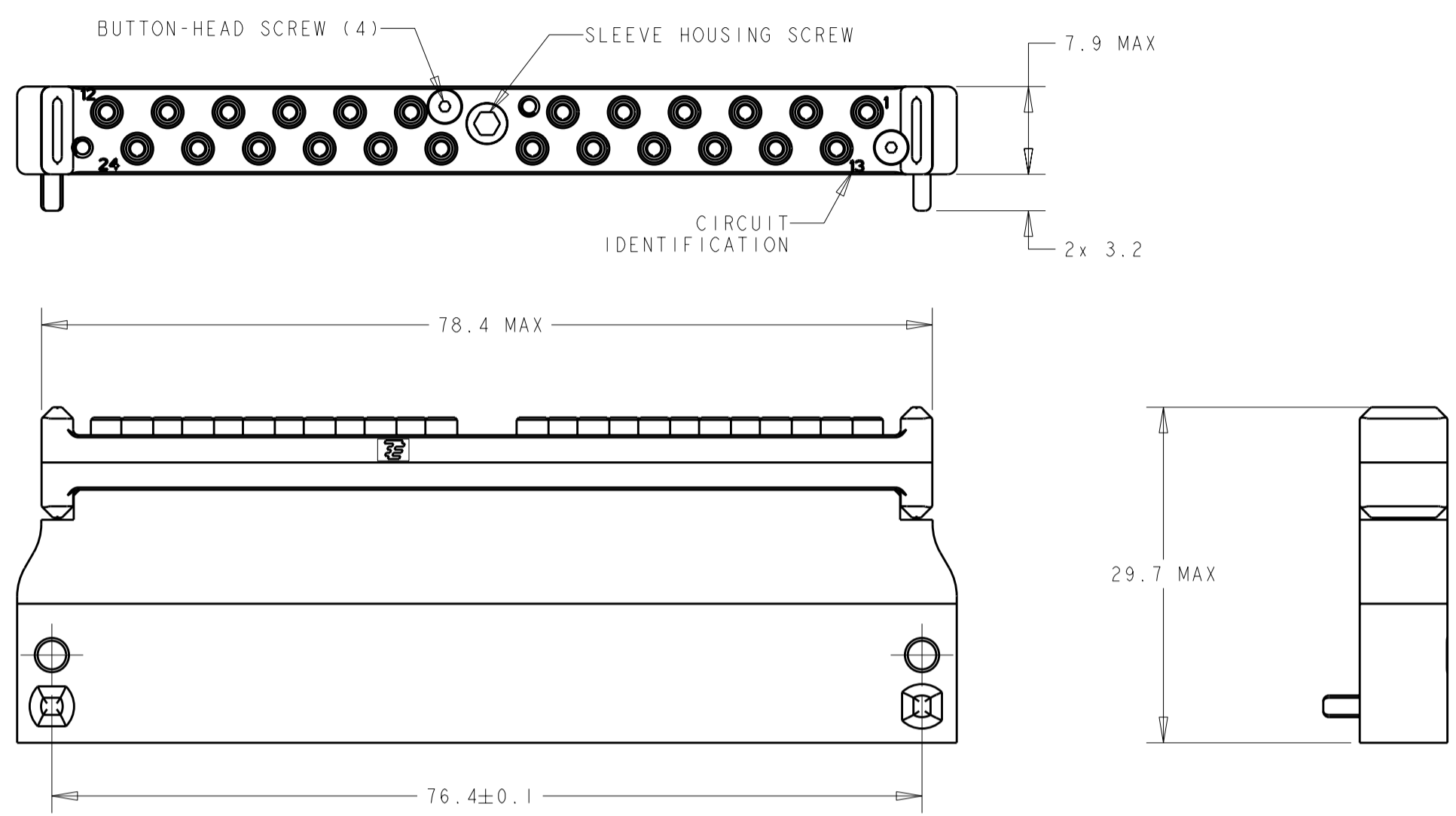

RECOMMENDED PCB LAY-OUT 8 9

- 1 SLEEVE HOUSING: ALUMINUM ALLOY 6061, FRONT & REAR HOUSING: GLASS-FILLED LCP THERMOPLASTIC, UL 94 V-0 RATED, COLOR: NATURAL (BEIGE). TERMINI RETENTION CLIP: STAINLESS STEEL PER AISI 301. SLEEVE HOUSING SCREW & HOUSING NUT: STAINLESS STEEL PER AISI 303. REAR SCREW AND BUTTON-HEAD SCREW: STAINLESS STEEL. SLEEVES: ZIRCONIA
- 2 SLEEVE HOUSING: ANODIZED PER MIL-A-8625, COLOR: GOLD.
- 3 POCKETS FOR 4.76 [3/16 in] HEX NUT
- 4 AREA REQUIRED FOR CONNECTOR PLACEMENT.
- 5 DATUM ESTABLISHED BY CUSTOMER.
- 6 BASIC DIMENSION ESTABLISHED BY CUSTOMER.
- 7 DATE CODE: YEAR & WEEK (YY WW)
- 8 MISALIGNMENT ALLOWED BETWEEN THE MODULE CONNECTOR & THE CUTOUT FOR THE BACKPLANE CONNECTOR, TYCO PART NUMBER 1738965-1: 1mm MAX
- 9 ACCOMMODATES PC BOARD THICKNESS RANGE 1.47-3.05 mm.
- 10. RECOMMENDED TERMINI APPLICATION TOOLING:  
 INSTALLING TOOL: DANIELS MFG. CORP. P/N DAK83-16  
 REMOVAL TOOL: DANIELS MFG. CORP. P/N DRK83-16
- 11. THE SLEEVE HOLDER ASSEMBLY, 1954573-1, IS AVAILABLE SEPARATELY.
- 12. LuxCis® IS A REGISTERED TRADEMARK OF RADIALL SA.

1738960-2
SUPERCEDED BY: 1738960-2
1738960-1
PART NUMBER

THIS DRAWING IS A CONTROLLED DOCUMENT FOR TYCO ELECTRONICS CORPORATION. IT IS SUBJECT TO CHANGE AND THE CONTROLLING ENGINEERING ORGANIZATION SHOULD BE CONTACTED FOR THE LATEST REVISION.		DWN	BH	09MAY2004	Tyco Electronics Harrisburg, PA 17105-3608
DIMENSIONS: mm		CHK	JPM	09MAY2004	
TOLERANCES UNLESS OTHERWISE SPECIFIED:		APVD	JPM	09MAY2004	
0 PLC ±0.1 1 PLC ±0.1 2 PLC ±0.1 3 PLC ± 4 PLC ± ANGLES ± FINISH		PRODUCT SPEC	108-2247		NAME CONNECTOR, MODULE, 24 POSITION, FOR LuxCis OPTICAL TERMINI
MATERIAL		APPLICATION SPEC	114-13192		
1 - 2 -		WEIGHT	-		SIZE A2
CUSTOMER DRAWING		SCALE	2:1		CAGE CODE 00779
		SHEET	1		DRAWING NO 1738960
		OF	1		RESTRICTED TO -
		REV	A		