



Chipsmall Limited consists of a professional team with an average of over 10 year of expertise in the distribution of electronic components. Based in Hongkong, we have already established firm and mutual-benefit business relationships with customers from,Europe,America and south Asia,supplying obsolete and hard-to-find components to meet their specific needs.

With the principle of “Quality Parts,Customers Priority,Honest Operation,and Considerate Service”,our business mainly focus on the distribution of electronic components. Line cards we deal with include Microchip,ALPS,ROHM,Xilinx,Pulse,ON,Everlight and Freescale. Main products comprise IC,Modules,Potentiometer,IC Socket,Relay,Connector.Our parts cover such applications as commercial,industrial, and automotives areas.

We are looking forward to setting up business relationship with you and hope to provide you with the best service and solution. Let us make a better world for our industry!



Contact us

Tel: +86-755-8981 8866 Fax: +86-755-8427 6832

Email & Skype: info@chipsmall.com Web: www.chipsmall.com

Address: A1208, Overseas Decoration Building, #122 Zhenhua RD., Futian, Shenzhen, China



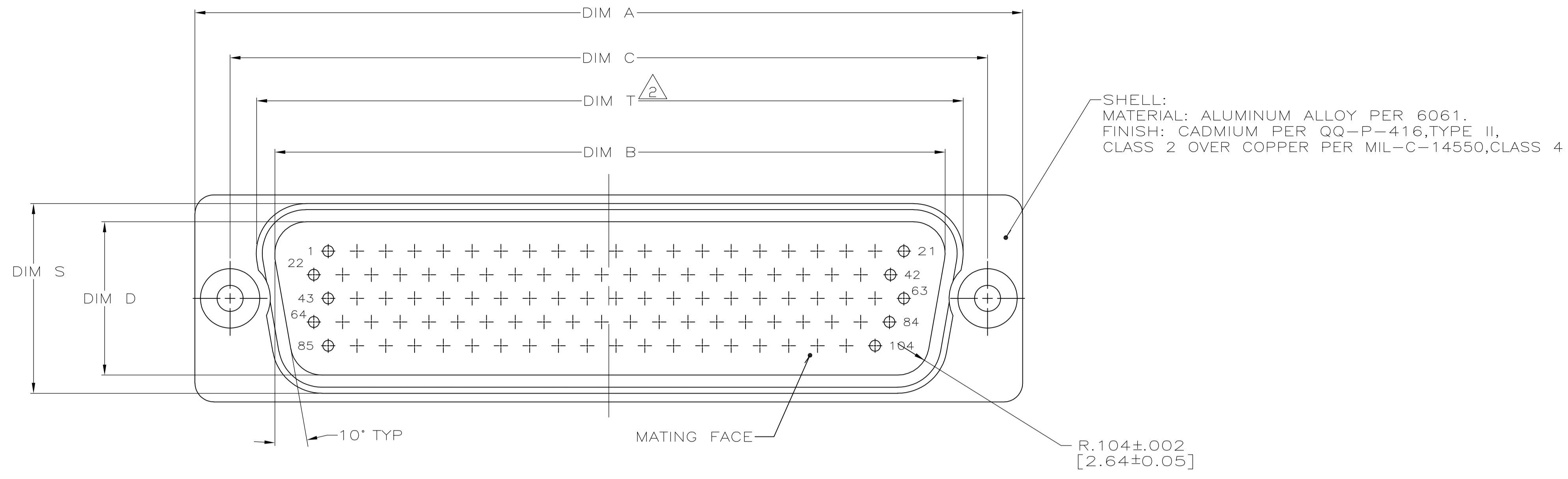

▲ MARKED WITH .047-.062 HIGH CHARACTERS.
 FAR SIDE REFERS TO THE WIDE SIDE OF THE KEYSTONE.
 NEAR SIDE REFERS TO THE NARROW SIDE OF THE KEYSTONE.
 IF PART IS TOO SMALL TO MARK ON FRONT OF SHELL, MARKING
 CAN BE SPLIT BETWEEN FRONT AND REAR OF SHELL

▲ FEATURE SHORTENED BY CLEARANCE RADIUS FOR FLOAT BUSHING.

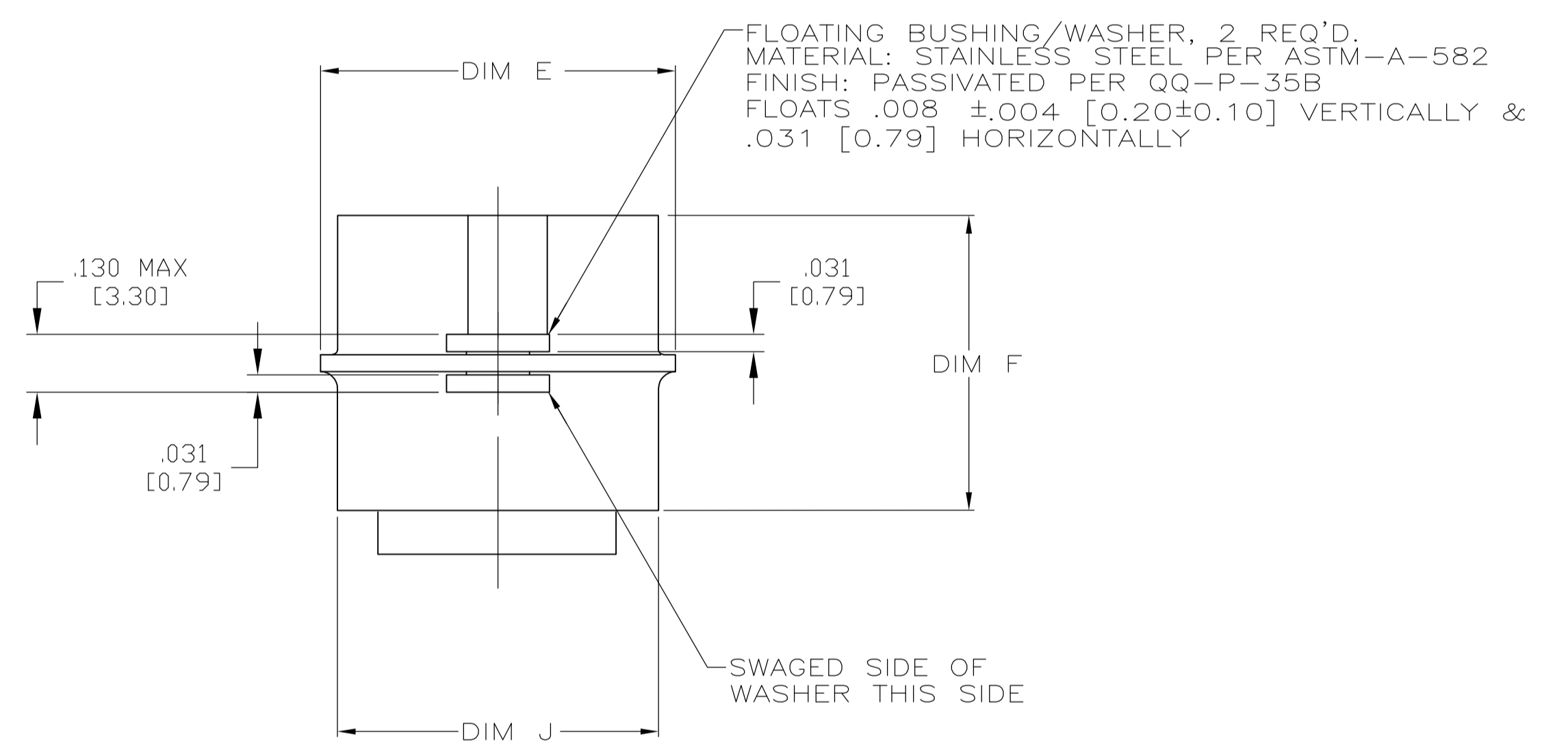
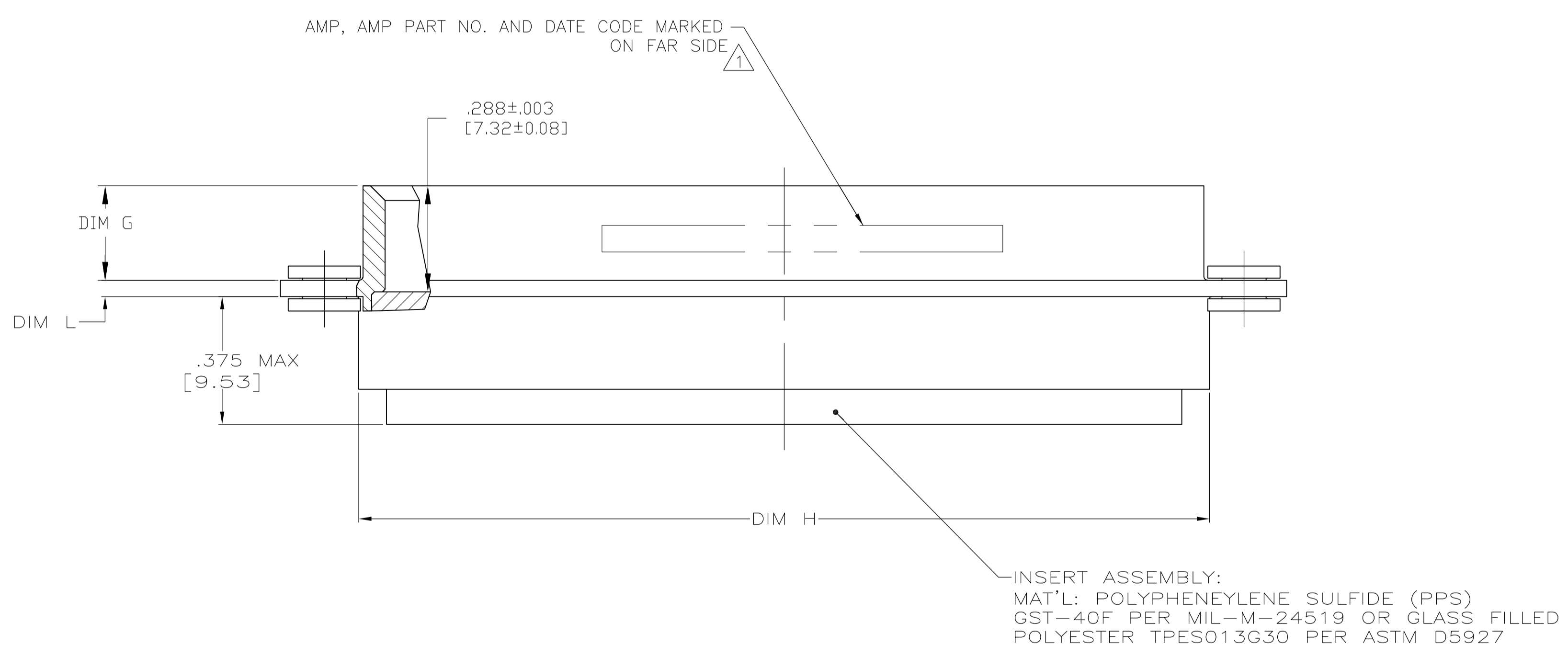

2.340 [59.44]	.610 [15.49]	.044 [1.12]	.614 [15.59]	2.319 [58.90]	.260 [6.60]	.569 [14.45]	.683 [17.35]	.509 [12.93]	2.505 [63.63]	2.218 [56.34]	2.744 [69.70]	104	6	1757207-6
2.192 [55.68]▲	.543 [13.79]	.044 [1.12]	.556 [14.12]	2.195 [55.75]	.260 [6.60]	.569 [14.45]	.673 [17.09]	.503 [12.78]	2.495 [63.37]	2.212 [56.18]	2.714 [68.94]	78	5	1757207-5
1.650 [41.91]▲	.437 [11.10]	.044 [1.12]	.444 [11.28]	1.642 [41.71]	.260 [6.60]	.569 [14.45]	.610 [15.49]	.440 [11.18]	2.401 [60.98]	2.079 [52.81]	2.620 [66.55]	44	3	1757207-3
.782 [19.86]▲	.437 [11.10]	.035 [0.89]	.444 [11.28]	1.630 [41.40]	.254 [6.45]	.553 [14.30]	.499 [12.67]	.327 [8.31]	1.857 [47.17]	1.527 [38.78]	2.103 [53.42]	15	1	1757207-1
			.432 [10.97]	.776 [19.71]	.260 [6.60]	.569 [14.45]	.509 [12.93]	.327 [8.31]	.989 [25.12]	.659 [16.74]	1.228 [31.19]			
			.432 [10.97]	.764 [19.41]	.254 [6.45]	.553 [14.30]	.499 [12.67]	.321 [8.15]	.979 [24.87]	.653 [16.59]	1.198 [30.43]			
T	S	L	J	H	G	F	E	D	C	B	A	NO OF POS	SHELL SIZE	PART NUMBER

THIS DRAWING IS A CONTROLLED DOCUMENT.

DIMENSIONS: INCHES	TOLERANCES UNLESS OTHERWISE SPECIFIED:	DIN C.C. THOMAS 02MAR2006	Tyco Electronics Corporation Harrisburg, PA 17105-3608
0 PLC ± -	1 PLC ± -	3-3-06	
2 PLC ± -	3 PLC ± .005	4 PLC ± -	RESTRICTED TO
ANGLES ± -			
MATERIAL	FINISH	WEIGHT	SCALE 4:1 SHEET 1 OF 1 REV G

APPROVED: D. MILLER, 3-3-06
 NAME: D. MILLER
 PRODUCT SPEC: PLUG ASSEMBLY, AMPLIMITE, SERIES 90, BLINDMATE
 SIZE: A1
 CAGE CODE: 00779
 DRAWING NO: 1757207
 CUSTOMER DRAWING