



Chipsmall Limited consists of a professional team with an average of over 10 year of expertise in the distribution of electronic components. Based in Hongkong, we have already established firm and mutual-benefit business relationships with customers from,Europe,America and south Asia,supplying obsolete and hard-to-find components to meet their specific needs.

With the principle of “Quality Parts,Customers Priority,Honest Operation,and Considerate Service”,our business mainly focus on the distribution of electronic components. Line cards we deal with include Microchip,ALPS,ROHM,Xilinx,Pulse,ON,Everlight and Freescale. Main products comprise IC,Modules,Potentiometer,IC Socket,Relay,Connector.Our parts cover such applications as commercial,industrial, and automotives areas.

We are looking forward to setting up business relationship with you and hope to provide you with the best service and solution. Let us make a better world for our industry!



Contact us

Tel: +86-755-8981 8866 Fax: +86-755-8427 6832

Email & Skype: info@chipsmall.com Web: www.chipsmall.com

Address: A1208, Overseas Decoration Building, #122 Zhenhua RD., Futian, Shenzhen, China



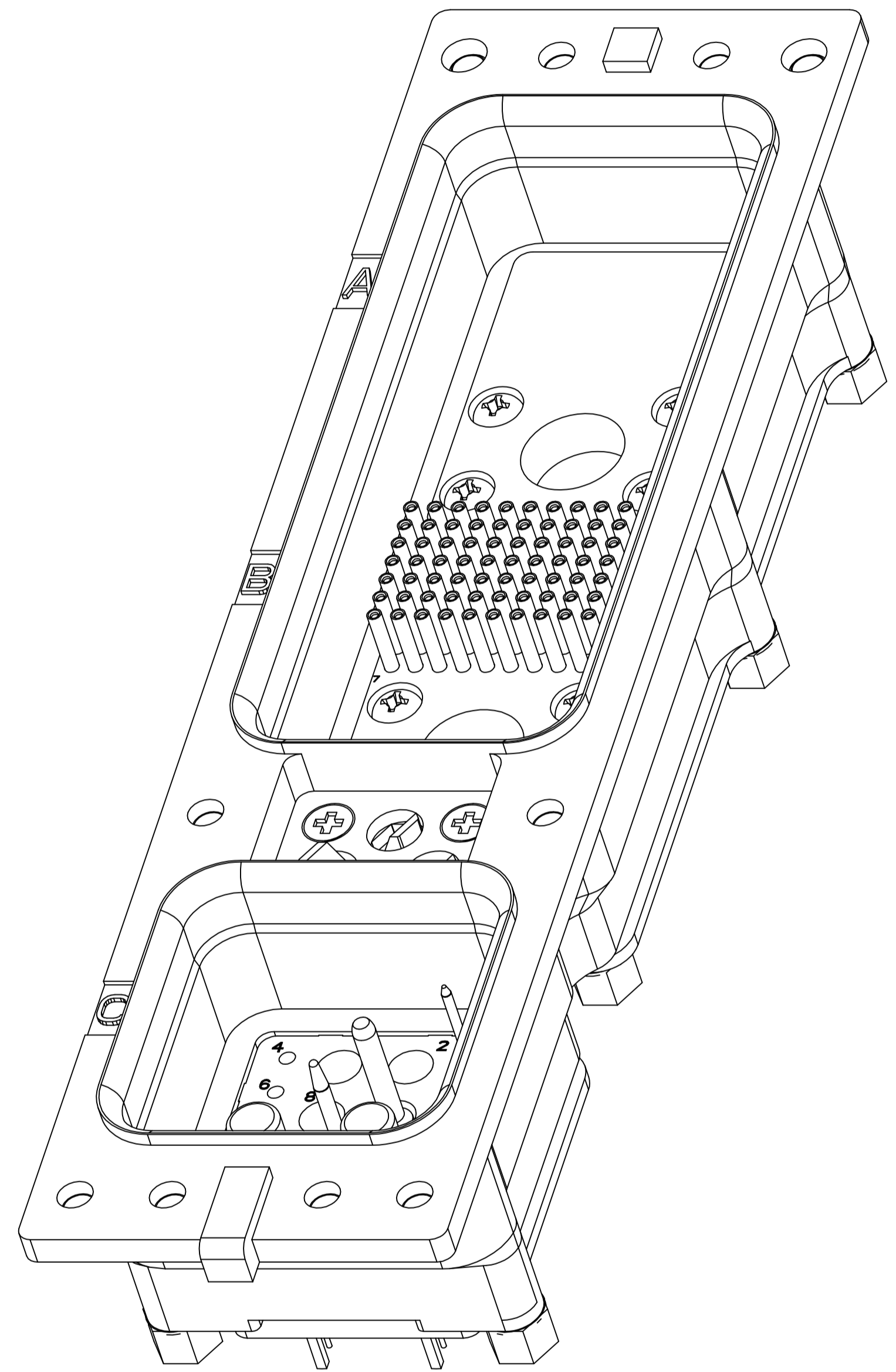

1. CONNECTOR DIMENSIONS ARE PER ARINC 600 SPECIFICATION.
 2. CONNECTOR IS SUPPLIED WITH A DUST COVER INSTALLED; NOT SHOWN.
 3. KEYING SHOWN IN POSITION FOR ILLUSTRATION ONLY. CONNECTORS SHIPPED WITH KEYING INSTALLED IN POSITION PER TABLE. FOR POSITION "00" KEYING HARDWARE SHIPPED UNASSEMBLED.
 4. CONTACTS NOT SHOWN IN FRONT AND REAR VIEWS FOR CLARITY.
5. DIMENSION TO CONTACT POST IS WITH CONTACTS FULLY SEATED TO REAR OF CONTACT CAVITIES.
6. THE FOLLOWING CONTACTS AND FILLER PLUGS ARE LOADED IN THIS CONNECTOR:
 1757321-1:
 MODULE A:
 NONE
 MODULE B:
 P/N 211431-4 (SIZE 22 POSTED CONTACT; QTY = 70)
 MODULE C:
 P/N 448140-3 (SIZE 12 POSTED CONTACT; QTY = 4) POSITIONS 2, 3, 7 & 8.
 P/N 1-448139-1 (SIZE 16 POSTED; QTY = 1) POSITION 11.
 P/N 1484205-1 (SIZE 5 FILLER PLUG; QTY = 2) POSITIONS 12 & 13
 P/N 1663767-2 (SIZE 20 FILLER PLUG; QTY = 4) POSITIONS 1, 4, 5 & 6.
 P/N 1663767-3 (SIZE 16 FILLER PLUG; QTY = 2) POSITIONS 9 & 10.
7. THE FOLLOWING CONTACTS AND FILLER PLUGS ARE LOADED IN THIS CONNECTOR:
 1757321-2:
 MODULE A:
 NONE
 MODULE B:
 P/N 211431-4 (SIZE 22 POSTED CONTACT; QTY = 70)
 MODULE C:
 P/N 448140-3 (SIZE 12 POSTED CONTACT; QTY = 1) POSITION 2.
 P/N 1-448139-1 (SIZE 16 POSTED; QTY = 2) POSITIONS 9 & 10
 P/N 1484205-1 (SIZE 5 FILLER PLUG; QTY = 2) POSITIONS 12 & 13
 P/N 1663767-2 (SIZE 20 FILLER PLUG; QTY = 4) POSITIONS 1, 4, 5 & 6.
 P/N 1663767-3 (SIZE 16 FILLER PLUG; QTY = 1) POSITION 11.
 P/N 1663767-4 (SIZE 12 FILLER PLUG; QTY = 3) POSITIONS 3, 7 & 8.
8. HARDWARE FOR SIZE 1 CONTACTS INCLUDES RETAINER PLATE, P/N 1757721-1, QTY = 1 AND SCREWS, P/N 211558-1, QTY = 4. HARDWARE IS SHOWN ASSEMBLED BUT SHIPPED UNASSEMBLED.

COMPONENT	MATERIAL	FINISH
SHELL	ALUMINUM ALLOY A380 PER ASTM-B-85	ELECTROLESS NICKEL PER MIL-C-26074
RETENTION PLATES	ALUMINUM ALLOY PER ASTM-B-209	ELECTROLESS NICKEL PER MIL-C-26074
PAN HEAD SCREWS AND LOCKWASHERS	STAINLESS STEEL	PASSIVATED
FLAT HEAD SCREWS (FOR KEYING HARDWARE)	STAINLESS STEEL	PASSIVATED
POLARIZING KEYS	ZINC ALLOY PER ASTM-B-86	-
POLARIZING KEY RETAINING PLATE	ALUMINUM ALLOY PER ASTM-B-209	BLUE ANODIZED PER MIL-A-8625
INSERTS AND RETAINER PLATE FOR SIZE 1	ALUMINUM ALLOY PER ASTM-B-209	ELECTROLESS NICKEL PER MIL-C-26074
71C1 & 13C2 INSERTS	THERMOSET OR THERMOPLASTIC PPS PER MIL-M-24519	-
STANDOFF	STAINLESS STEEL	PASSIVATED

01	7	1757321-2
01	6	1757321-1
KEYING POSITION	CONTACTS INCLUDED AND INSTALLED	PART NUMBER

THIS DRAWING IS A CONTROLLED DOCUMENT.

DIMENSIONS: INCHES [mm]	TOLERANCES UNLESS OTHERWISE SPECIFIED:	DRAWN: C.C.THOMAS 9-6-04	CHK: K.HOGAN 9-6-04	APVD: K.HOGAN 9-6-04	NAME: RCPT ASSY, SIZE 2, ARINC 600 (C2/71C1/13C2)
0 PLC ± -	1 PLC ± -	2 PLC ± -	3 PLC ± -	4 PLC ± .005 [0.13]	ANGLES ± -
MATERIAL: SEE TABLE	FINISH: SEE TABLE	WEIGHT: -	SIZE: A1	CAGE CODE: 00779	DRAWING NO: 1757321
CUSTOMER DRAWING			SCALE: 3:2	SHEET: 1 OF 2	REV: F

Tyco Electronics Corporation
 Harrisburg, Pa 17105-3608

