



Chipsmall Limited consists of a professional team with an average of over 10 year of expertise in the distribution of electronic components. Based in Hongkong, we have already established firm and mutual-benefit business relationships with customers from,Europe,America and south Asia,supplying obsolete and hard-to-find components to meet their specific needs.

With the principle of “Quality Parts,Customers Priority,Honest Operation,and Considerate Service”,our business mainly focus on the distribution of electronic components. Line cards we deal with include Microchip,ALPS,ROHM,Xilinx,Pulse,ON,Everlight and Freescale. Main products comprise IC,Modules,Potentiometer,IC Socket,Relay,Connector.Our parts cover such applications as commercial,industrial, and automotives areas.

We are looking forward to setting up business relationship with you and hope to provide you with the best service and solution. Let us make a better world for our industry!



Contact us

Tel: +86-755-8981 8866 Fax: +86-755-8427 6832

Email & Skype: info@chipsmall.com Web: www.chipsmall.com

Address: A1208, Overseas Decoration Building, #122 Zhenhua RD., Futian, Shenzhen, China



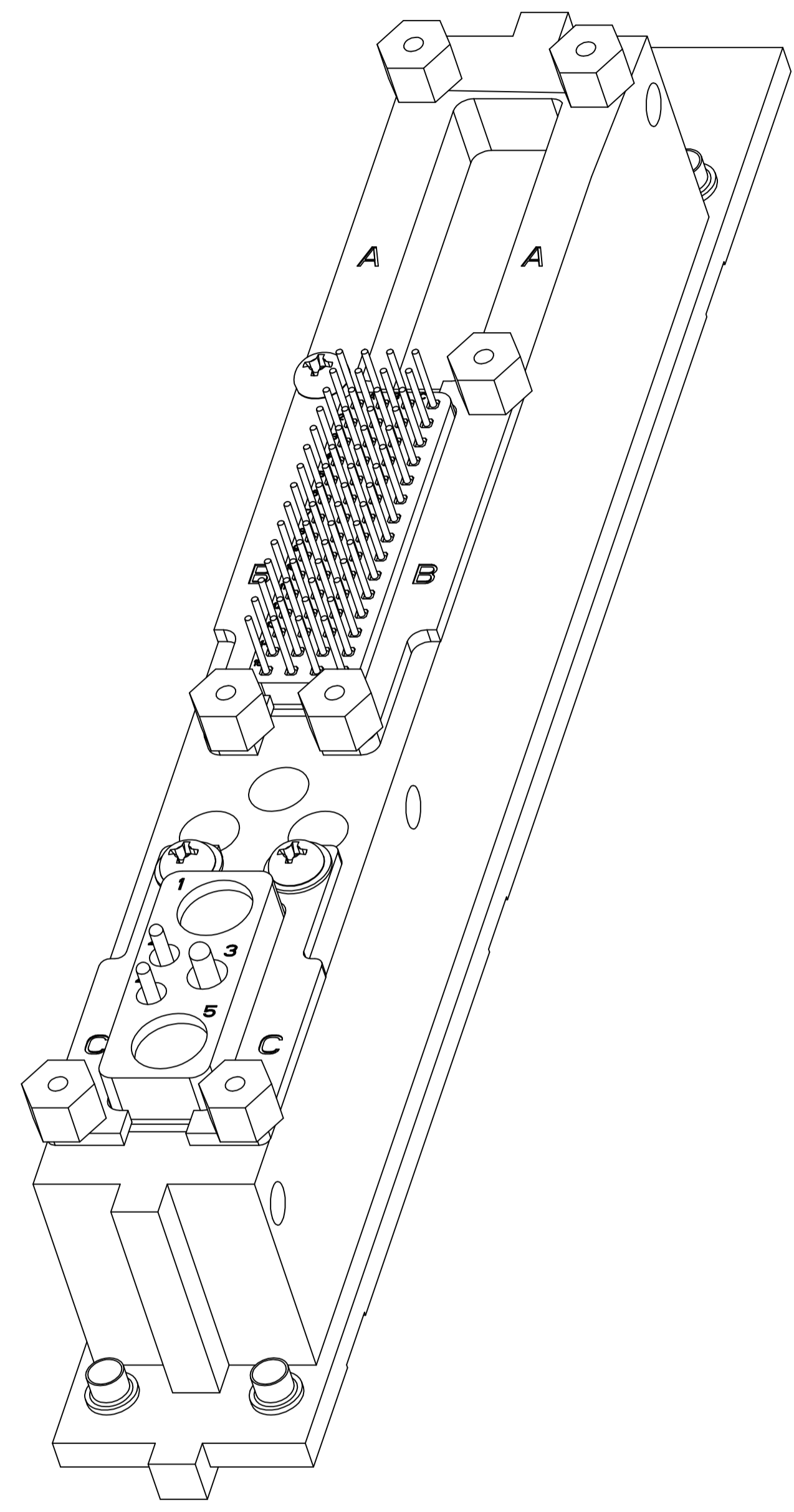
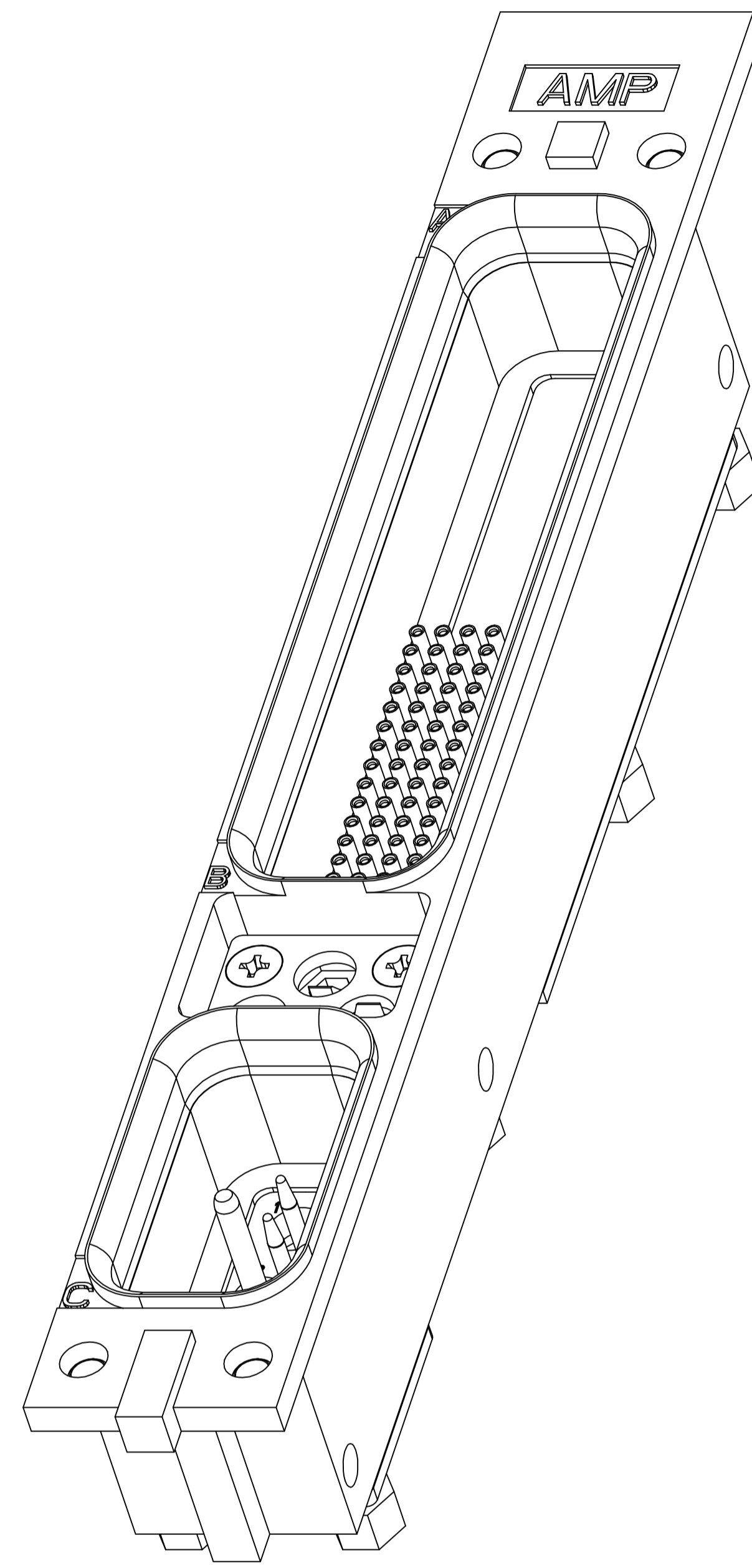

- CONNECTOR DIMENSIONS ARE PER ARINC 600 SPECIFICATION
- CONTACTS NOT SHOWN IN FRONT & REAR VIEWS FOR CLARITY.
- KEYING SHOWN IN POSITION FOR REFERENCE ONLY. SEE TABLE FOR KEYING POSITION. FOR POSITION "00" KEYING SHIPPED UNASSEMBLED.
- INSTALLED CONT AND FILLER PLUG LOCATIONS:
 CAVITY B: SIZE 22 POSTED; QTY=60 (P/N 211431-4)
 CAVITY C: SIZE 16 POSTED; QTY=2; POSITIONS 2 & 4; (P/N 1-1663128-0)
 SIZE 12 POSTED; QTY=1; POSITION 3; (P/N 1663129-8)
 SIZE 5 FILLER PLUG; QTY=2; POSITION 1 & 5 (P/N 1663132-1)
- DIMENSION APPLIES WITH CONTACTS FULLY SEATED TO REAR OF CONTACT CAVITIES.

COMPONENT	MATERIAL	FINISH
SHELL	ALUMINUM ALLOY A380 PER ASTM-B-85	ELECTROLESS NICKEL PER MIL-C-26074
RETENTION PLATES	ALUMINUM ALLOY PER ASTM-B-209	ELECTROLESS NICKEL PER MIL-C-26074
PAN HEAD SCREWS AND LOCKWASHERS	STAINLESS STEEL	PASSIVATED
FLAT HEAD SCREWS (FOR KEYING HARDWARE)	STAINLESS STEEL	PASSIVATED
POLARIZING KEYS	ZINC ALLOY PER ASTM-B-86	-
POLARIZING KEY RETAINING PLATE	ALUMINUM ALLOY PER ASTM-B-209	BLUE ANODIZED PER MIL-A-8625
BLANK INSERT	TEFLON	-
60 & 5C2 INSERTS	THERMOSET	-
STANDOFF	STAINLESS STEEL	PASSIVATED

THIS DRAWING IS A CONTROLLED DOCUMENT.

DIMENSIONS: INCHES [mm]	TOLERANCES UNLESS OTHERWISE SPECIFIED:
0 PLC ± -	1 PLC ± -
2 PLC ± -	3 PLC ± .005 [0.13]
4 PLC ± -	ANGLES ± -

MATERIAL SEE TABLE FINISH SEE TABLE

DWN: C.C.THOMAS 1-4-05	Tyco Electronics Corporation Harrisburg, Pa 17105-3608
CHK: K.HOGAN 1-4-05	
APP'D: K.HOGAN 1-4-05	RCPT ASSY, SIZE 1, ARINC 600 (BLANK/60/5C2)
PRODUCT SPEC	
APPLICATION SPEC	
RESTRICTED TO	
SIZE: A1	CAGE CODE: 00779
DRAWING NO: 1757681	SCALE: 2:1
WEIGHT: -	SHEET 1 OF 2
CUSTOMER DRAWING	REV F

LOC		DIST		REVISIONS			
DF	AO	F	LTR	DESCRIPTION	DATE	DN	APVD
				SEE SHEET #1			

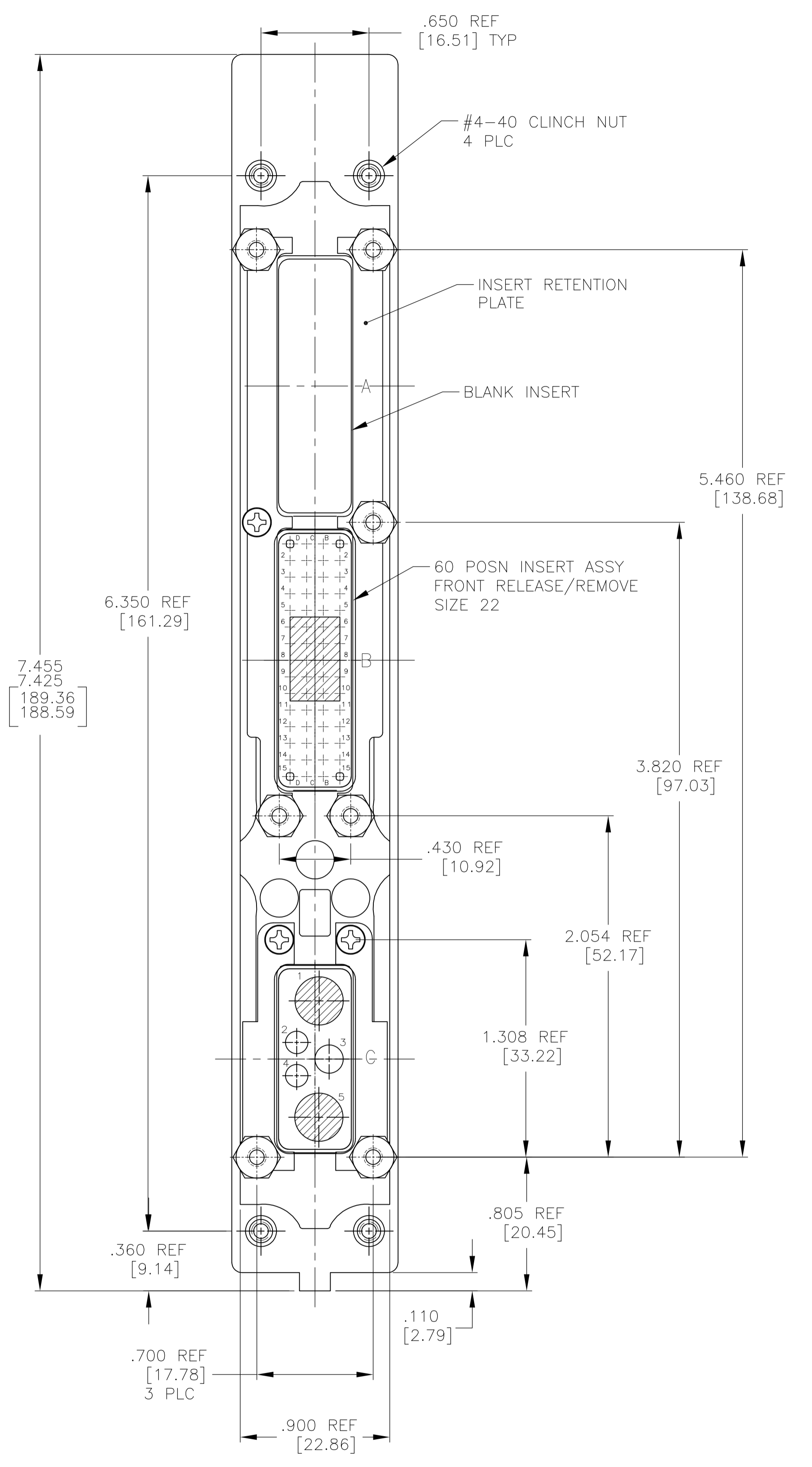
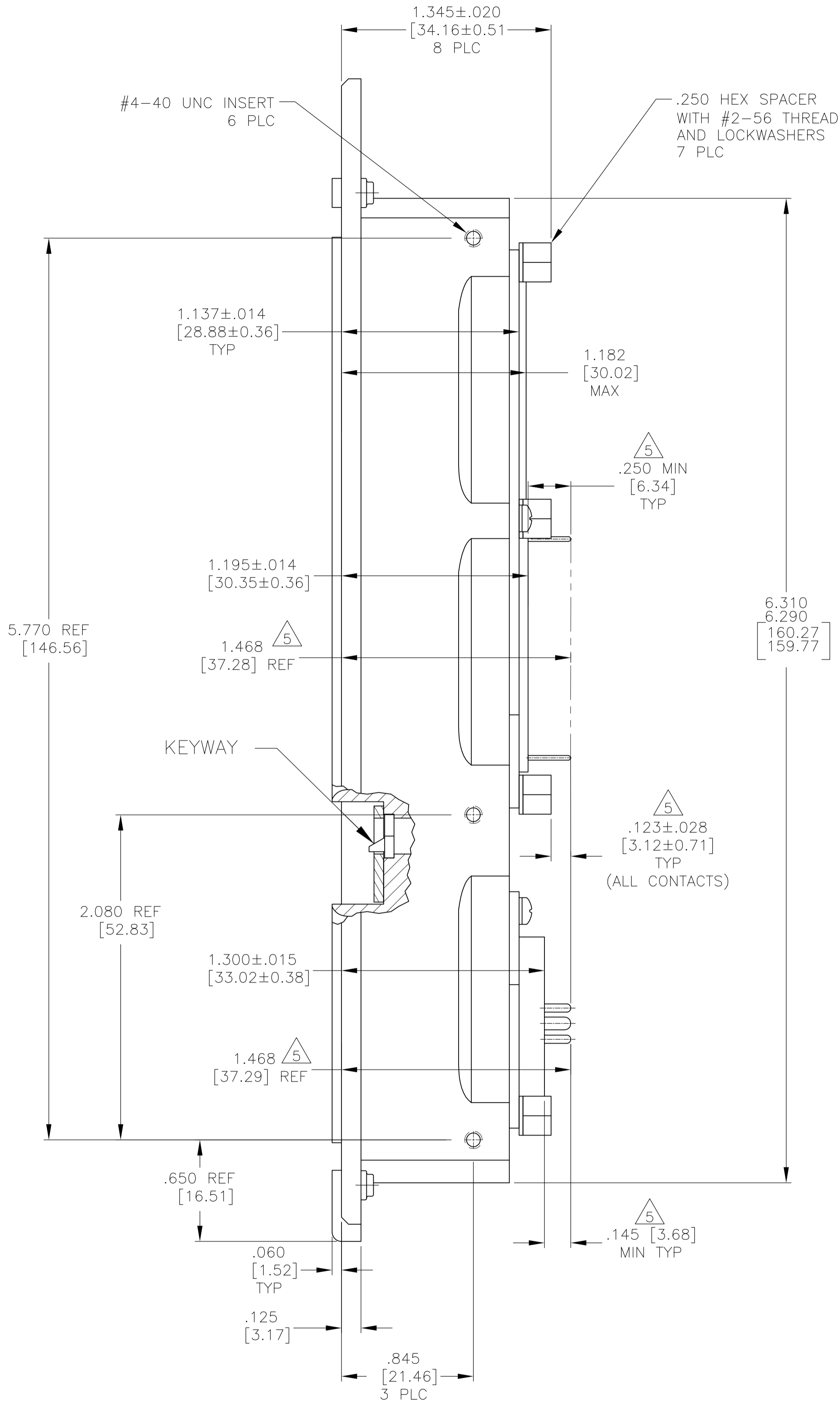
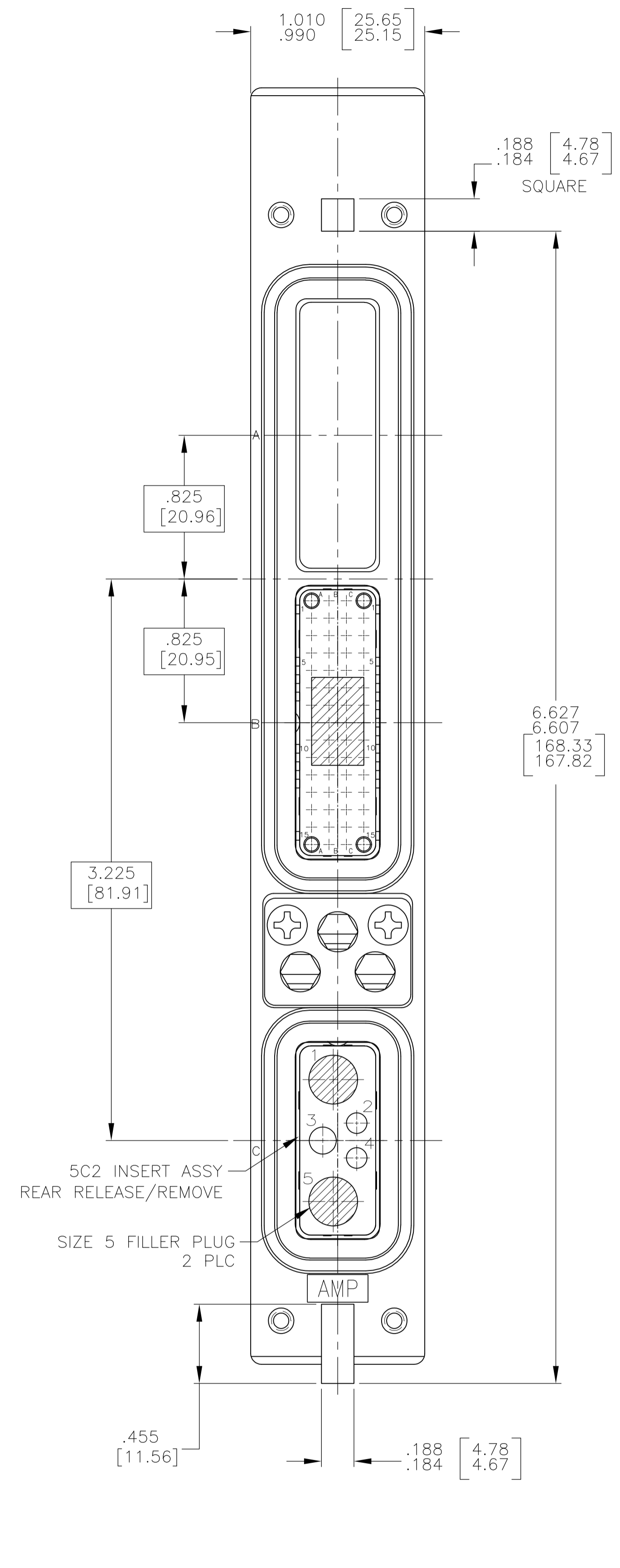

THIS DRAWING IS A CONTROLLED DOCUMENT.		DN C.C.THOMAS 1-4-05	Tyco Electronics Corporation Harrisburg, Pa 17105-3608																		
DIMENSIONS: INCHES [mm]		CHK K.HOGAN 1-4-05																			
TOLERANCES UNLESS OTHERWISE SPECIFIED:		APVD K.HOGAN 1-4-05	NAME RCPT ASSY, SIZE 1, ARINC 600 (BLANK/60/5C2)																		
<table border="1"> <tr><td>0 PLC</td><td>±</td><td>-</td></tr> <tr><td>1 PLC</td><td>±</td><td>-</td></tr> <tr><td>2 PLC</td><td>±</td><td>-</td></tr> <tr><td>3 PLC</td><td>±</td><td>.005 [0.13]</td></tr> <tr><td>4 PLC</td><td>±</td><td>-</td></tr> <tr><td>ANGLES</td><td>±</td><td>-</td></tr> </table>		0 PLC	±	-	1 PLC	±	-	2 PLC	±	-	3 PLC	±	.005 [0.13]	4 PLC	±	-	ANGLES	±	-	APPLICATION SPEC	RESTRICTED TO
0 PLC	±	-																			
1 PLC	±	-																			
2 PLC	±	-																			
3 PLC	±	.005 [0.13]																			
4 PLC	±	-																			
ANGLES	±	-																			
MATERIAL SEE TABLE	FINISH SEE TABLE	WEIGHT -	SIZE A1																		
CUSTOMER DRAWING		SCALE 2:1	SHEET 2 OF 2																		