



Chipsmall Limited consists of a professional team with an average of over 10 year of expertise in the distribution of electronic components. Based in Hongkong, we have already established firm and mutual-benefit business relationships with customers from,Europe,America and south Asia,supplying obsolete and hard-to-find components to meet their specific needs.

With the principle of “Quality Parts,Customers Priority,Honest Operation,and Considerate Service”,our business mainly focus on the distribution of electronic components. Line cards we deal with include Microchip,ALPS,ROHM,Xilinx,Pulse,ON,Everlight and Freescale. Main products comprise IC,Modules,Potentiometer,IC Socket,Relay,Connector.Our parts cover such applications as commercial,industrial, and automotives areas.

We are looking forward to setting up business relationship with you and hope to provide you with the best service and solution. Let us make a better world for our industry!



Contact us

Tel: +86-755-8981 8866 Fax: +86-755-8427 6832

Email & Skype: info@chipsmall.com Web: www.chipsmall.com

Address: A1208, Overseas Decoration Building, #122 Zhenhua RD., Futian, Shenzhen, China



THIS DRAWING IS UNPUBLISHED. RELEASED FOR PUBLICATION
 © COPYRIGHT 2011 BY TE CONNECTIVITY. ALL RIGHTS RESERVED.

REVISIONS					
P	LTR	DESCRIPTION	DATE	DWN	APVD
J		REVISED PER ECR-16-005905	30MAY16	DZ	SL

NOTES:

- MATERIAL:
 HOUSING: LCP WITH 30% GF, UL94 V-0, BLACK COLOR.
 CONTACTS: PHOSPHOR BRONZE.
 PEGS: BRASS.
- FINISH:
 CONTACTS: (SEE TABLE) GOLD PLATED ON CONTACT AREA, GOLD FLASH ON SOLDER AREA, WITH ENTIRE CONTACT UNDERPLATED 1.27µm [50µ"] MIN. NICKEL.
 PEGS: 3.048µm [120µ"] MIN. MATTE-TIN OVER 1.27µm [50µ"] MIN. NICKEL.
- REFLOW SOLDER CAPABLE TO 260° PER TEC-109-201, CONDITION B.

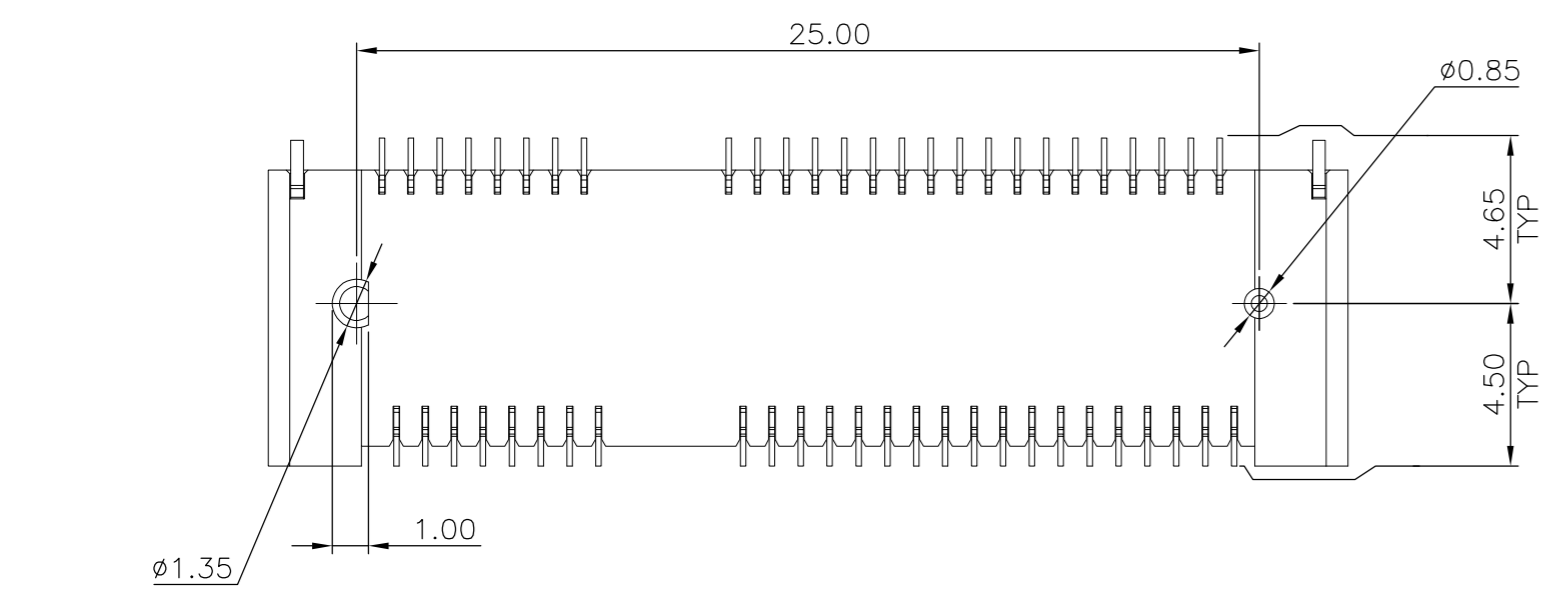
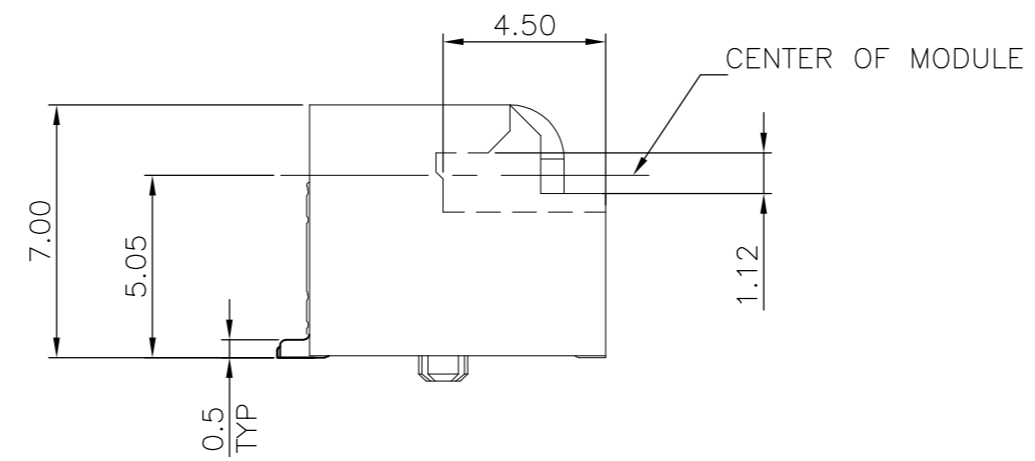
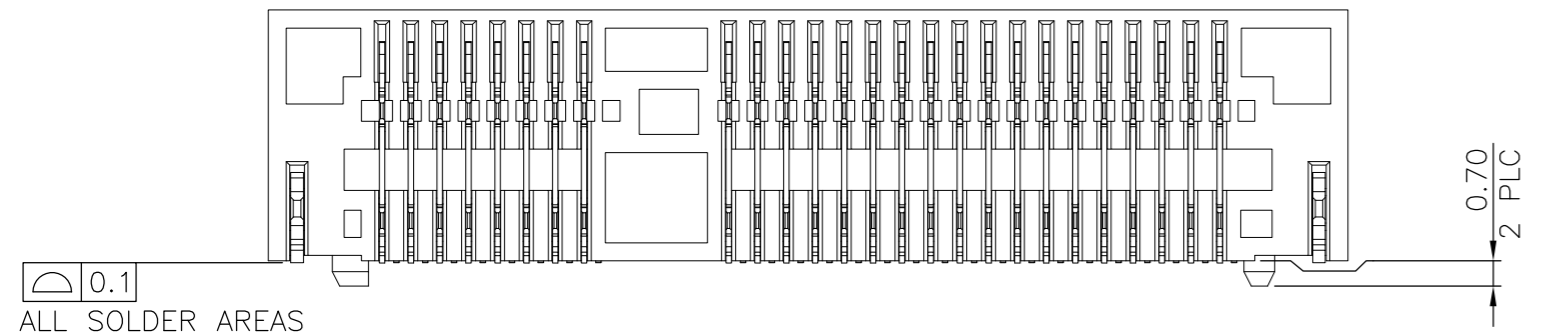
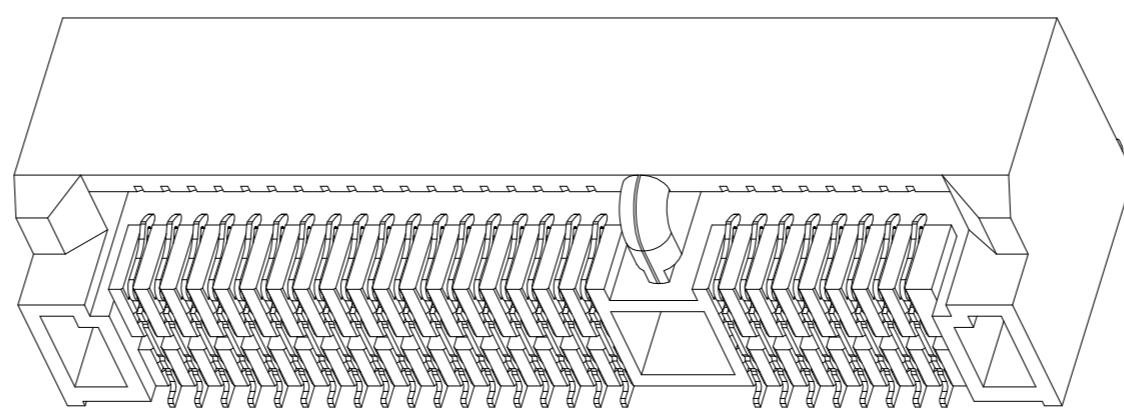
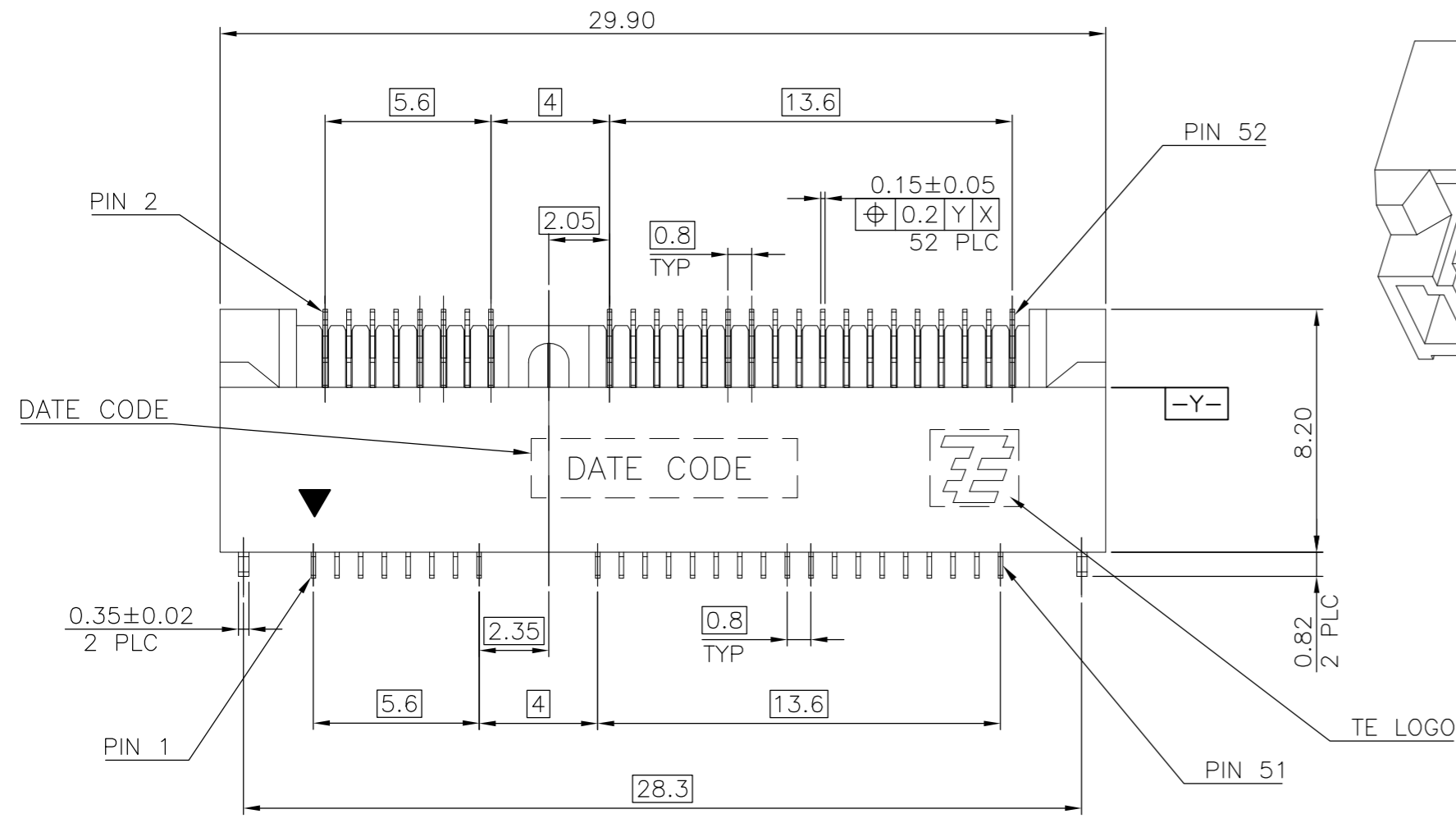
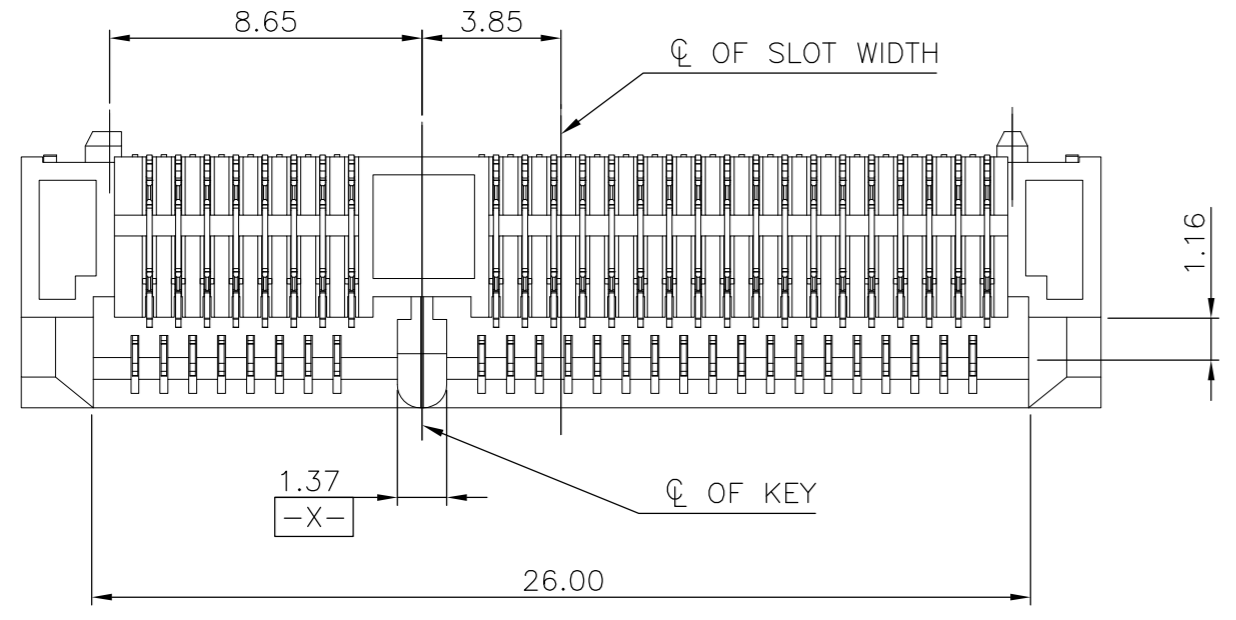

PCI-E MINI CARD CONNECTOR SIGNAL ASSIGNMENTS

PIN#	NAME	PIN#	NAME
51	Reserved	52	+3.3Vaux
49	Reserved	50	GND
47	Reserved	48	+1.5V
45	Reserved	46	LED_WPAN#
43	GND	44	LED_WLAN#
41	+3.3Vaux	42	LED_WWAN#
39	+3.3Vaux	40	GND
37	GND	38	USB_D+
35	GND	36	USB_D-
33	PETp0	34	GND
31	PETn0	32	SMB_DATA
29	GND	30	SMB_CLK
27	GND	28	+1.5V
25	PERp0	26	GND
23	PERn0	24	+3.3Vaux
21	GND	22	PERST#
19	Reserved* (UIM_C4)	20	W_DISABLE#
17	Reserved* (UIM_C8)	18	GND

MECHANICAL KEY

PIN#	NAME	PIN#	NAME
15	GND	16	UIM_VPP
13	REFCLK+	14	UIM_RESET
11	REFCLK-	12	UIM_CLK
9	GND	10	UIM_DATA
7	CLKREQ#	8	UIM_PWR
5	COEX2	6	1.5V
3	COEX1	4	GND
1	WAKE#	2	3.3Vaux

mSATA CONNECTOR SIGNAL ASSIGNMENTS

PIN#	NAME	PIN#	NAME
51	Presence Detection	52	+3.3V
49	DA/DSS	50	GND
47	Vendor	48	+1.5V
45	Vendor	46	Reserved
43	No Connect	44	Reserved
41	+3.3V	42	Reserved
39	+3.3V	40	GND
37	GND	38	Reserved
35	GND	36	Reserved
33	+A	34	GND
31	-A	32	Two Wire Interface
29	GND	30	Two Wire Interface
27	GND	28	+1.5V
25	-B	26	GND
23	+B	24	+3.3V
21	GND	22	Reserved
19	Reserved	20	Reserved
17	Reserved	18	GND

MECHANICAL KEY

PIN#	NAME	PIN#	NAME
15	GND	16	Reserved
13	Reserved	14	Reserved
11	Reserved	12	Reserved
9	GND	10	Reserved
7	Reserved	8	Reserved
5	Reserved	6	+1.5V
3	Reserved	4	GND
1	Reserved	2	+3.3V

* Reserved for future UIM interface (if needed)

OBSOLETE	0.762µm [30µ"]	1759547-4
OBSOLETE	0.381µm [15µ"]	1759547-3
OBSOLETE	0.254µm [10µ"]	1759547-2
	GOLD FLASH	1759547-1
	MIN. GOLD THICKNESS	PART NUMBER

THIS DRAWING IS A CONTROLLED DOCUMENT.

DWN	A. WU	01MAR2011
CHK	S. CHIEN	01MAR2011
APVD	W. KODAMA	01MAR2011

TE Connectivity

2 IN 1 mSATA & PCI EXPRESS MINI CARD CONNECTOR, 7 MM HEIGHT

108-99102

2.28 GRAMS

A2 00779 C=1759547

SCALE: 1 of 5

THIS DRAWING IS UNPUBLISHED. RELEASED FOR PUBLICATION
 © COPYRIGHT 2011 BY TE CONNECTIVITY. ALL RIGHTS RESERVED.

REVISIONS					
P	LTR	DESCRIPTION	DATE	DWN	APVD
J		SEE SHEET 1	-	-	-

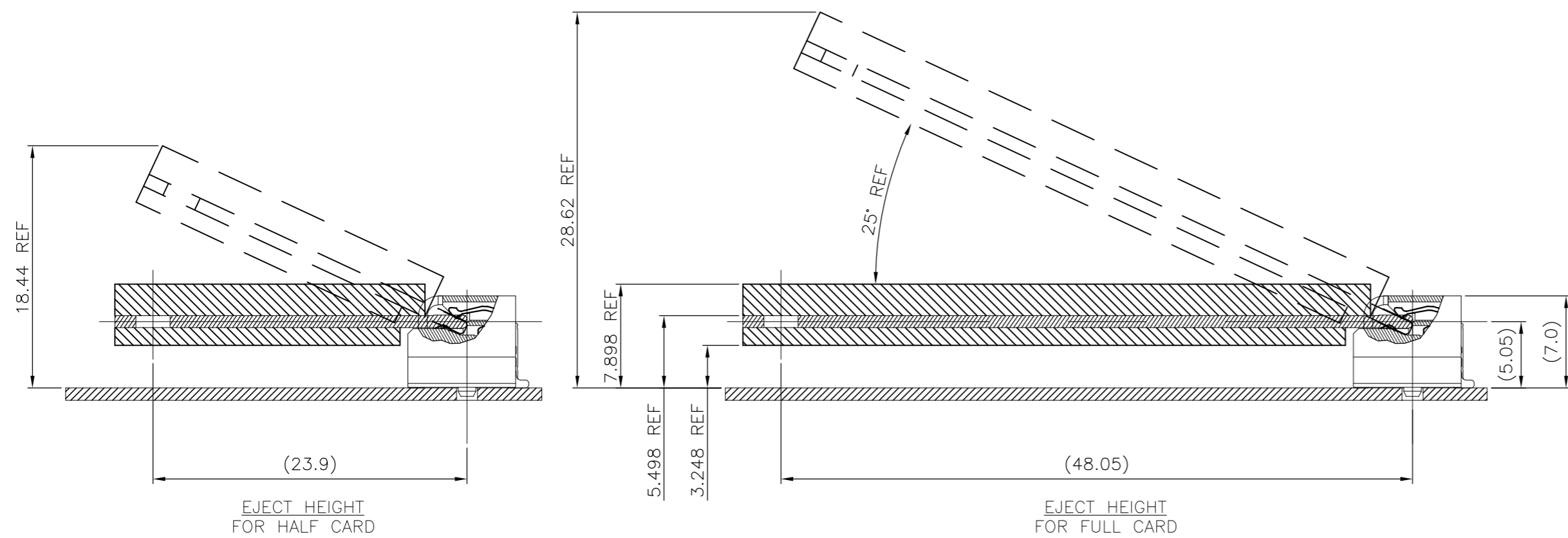

COMPONENT KEEP OUT AREA FOR CARD HOLD DOWN SOLUTION

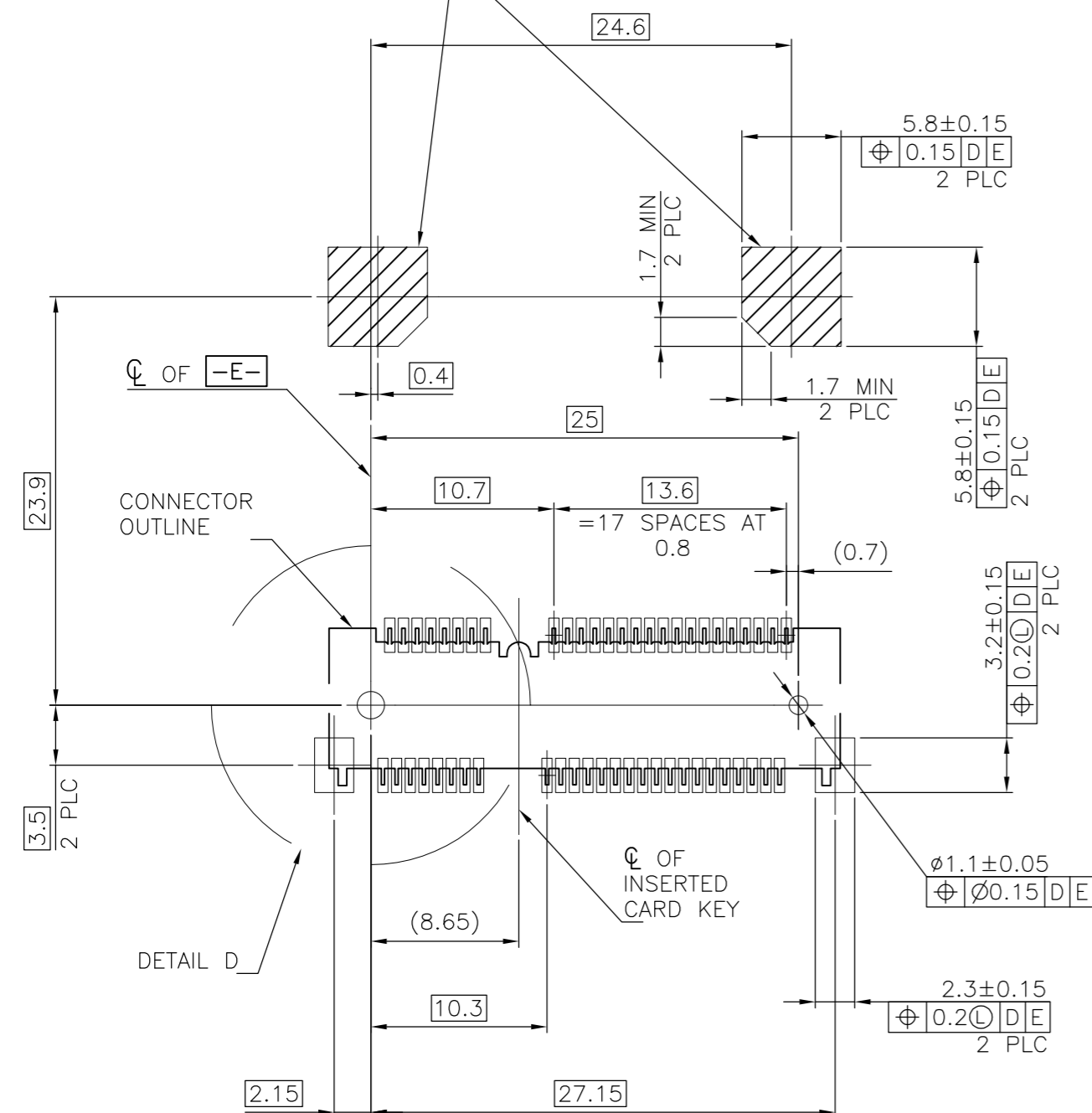

-D- IS THE TOP SURFACE OF PCB.
 RECOMMENDED P.C. BOARD PATTERN LAYOUT FOR HALF CARD CONNECTOR (TOP VIEW)

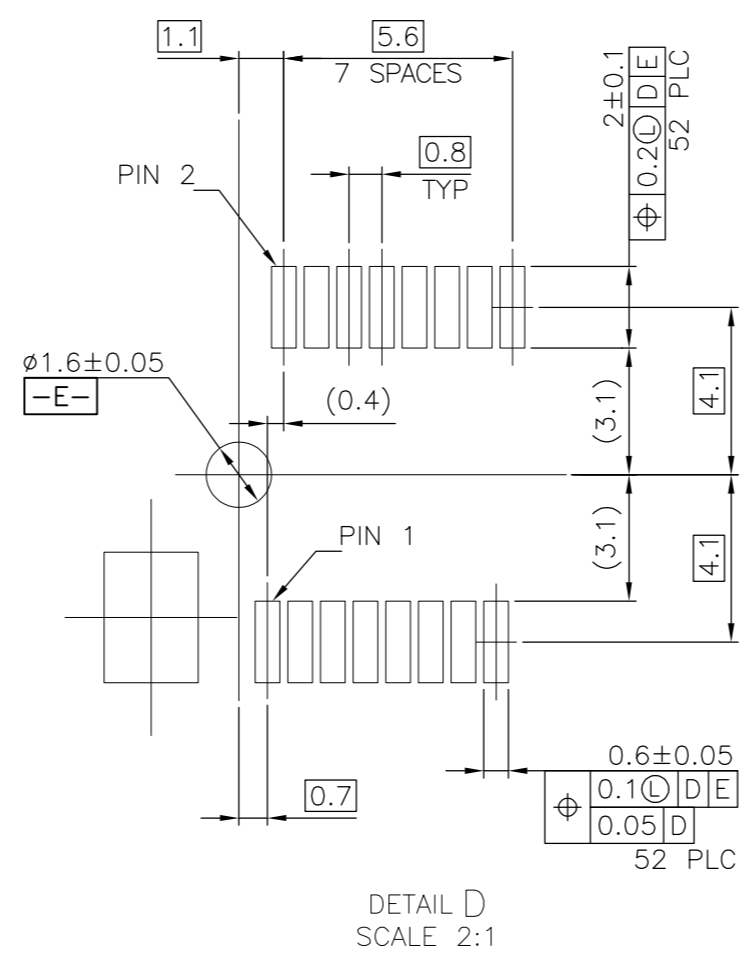

COMPONENT KEEP OUT AREA FOR CARD HOLD DOWN SOLUTION

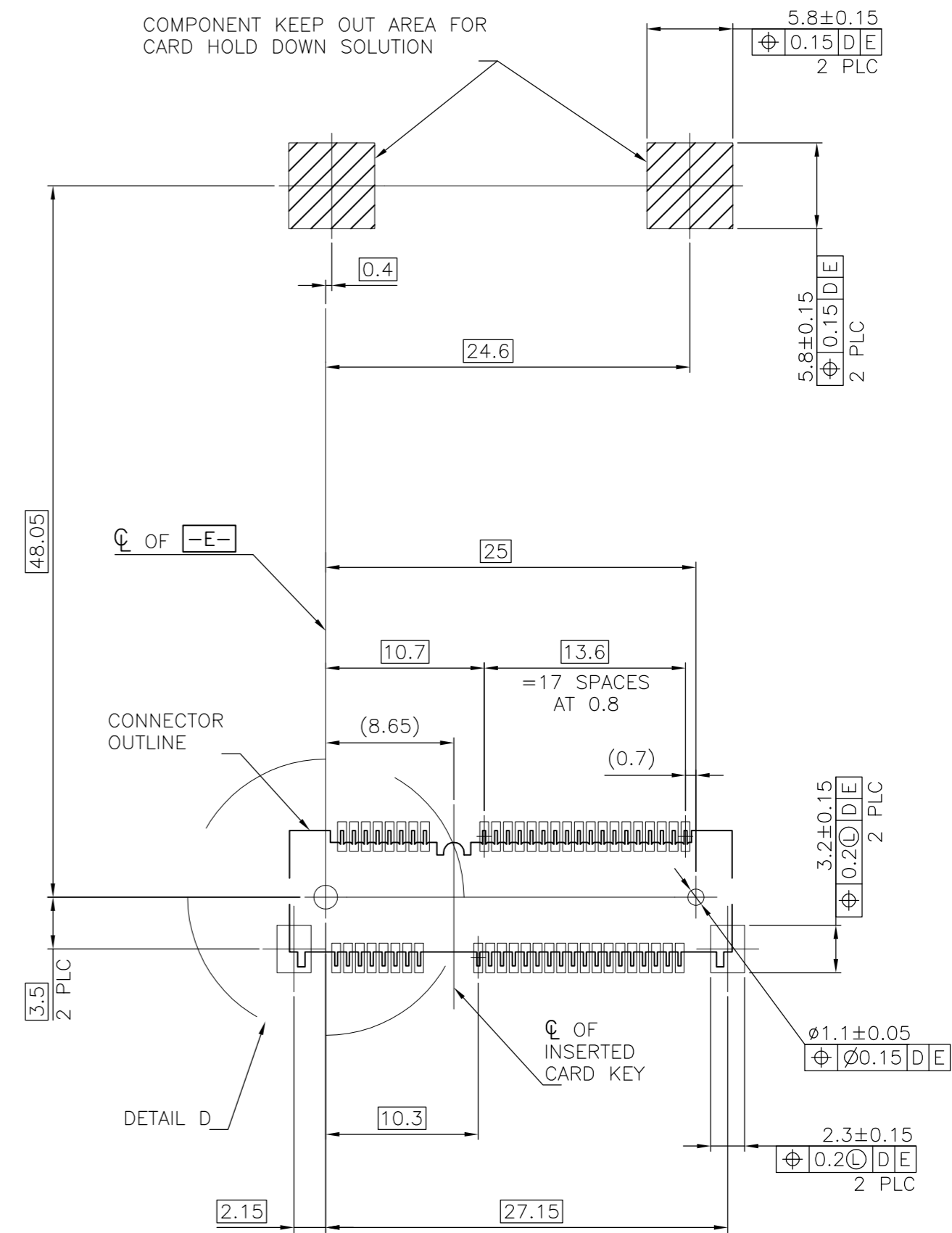

-D- IS THE TOP SURFACE OF PCB.
 RECOMMENDED P.C. BOARD PATTERN LAYOUT FOR FULL CARD CONNECTOR (TOP VIEW)

THIS DRAWING IS A CONTROLLED DOCUMENT.		DWN	31MAY2016	TE TE Connectivity	
DIMENSIONS: mm		CHK	-		
TOLERANCES UNLESS OTHERWISE SPECIFIED:		APVD	-	NAME	
0 PLC	± -	PRODUCT SPEC	-	2 IN 1 mSATA & PCI EXPRESS MINI CARD CONNECTOR, 7 MM HEIGHT	
1 PLC	± -	APPLICATION SPEC	-	SIZE	CAGE CODE
2 PLC	± -			A2	00779
3 PLC	± -			DRAWING NO	C=1759547
4 PLC	± -			RESTRICTED TO	-
ANGLES	± -	WEIGHT	-	SCALE	SHEET
FINISH	-	CUSTOMER DRAWING	-	-	2 OF 5
				REV	J

REVISIONS					
P	LTR	DESCRIPTION	DATE	DWN	APVD
J		SEE SHEET 1	-	-	-

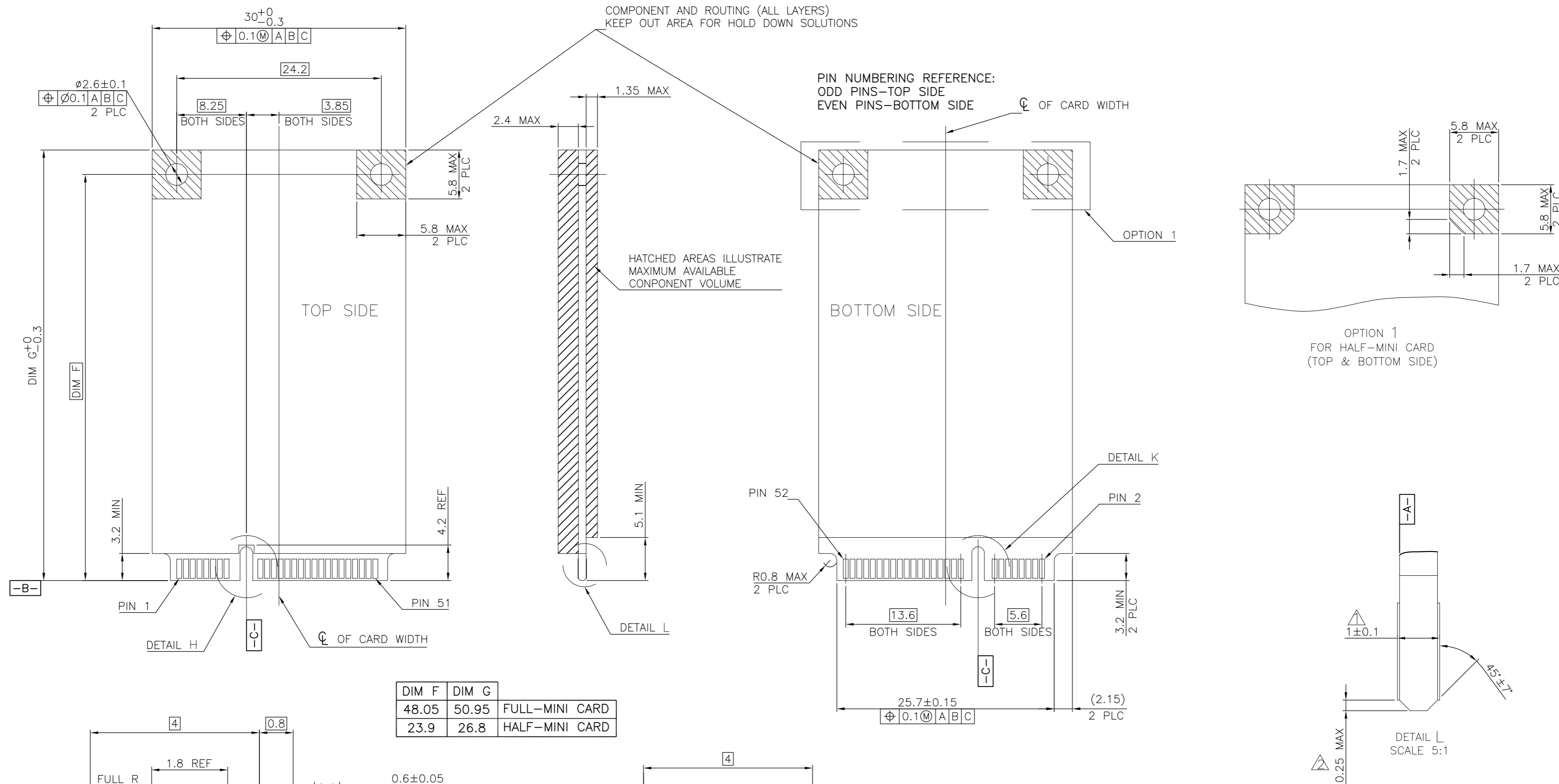

DIM F	DIM G	
48.05	50.95	FULL-MINI CARD
23.9	26.8	HALF-MINI CARD

- NOTES:
- △ CARD THICKNESS APPLIES ACROSS TABS AND INCLUDES PLATING AND/OR METALLIZATION.
 - △ EDGE BEVEL MUST BE PRESENT AND FREE OF CUTTING BURRS FROM PCB AND CONTACT MATERIALS.

FOR PCI EXPRESS MINI CARD

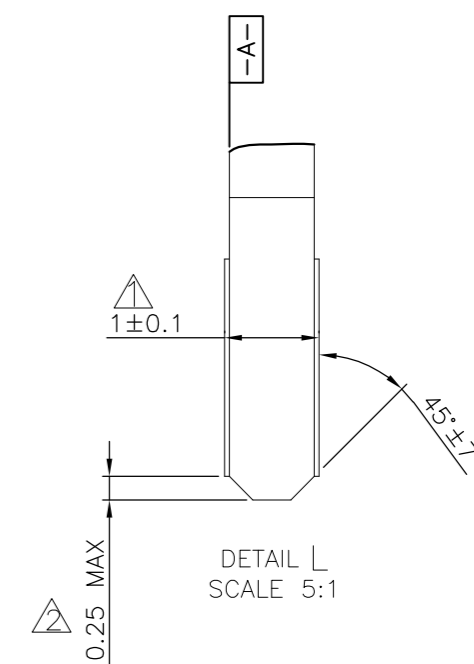
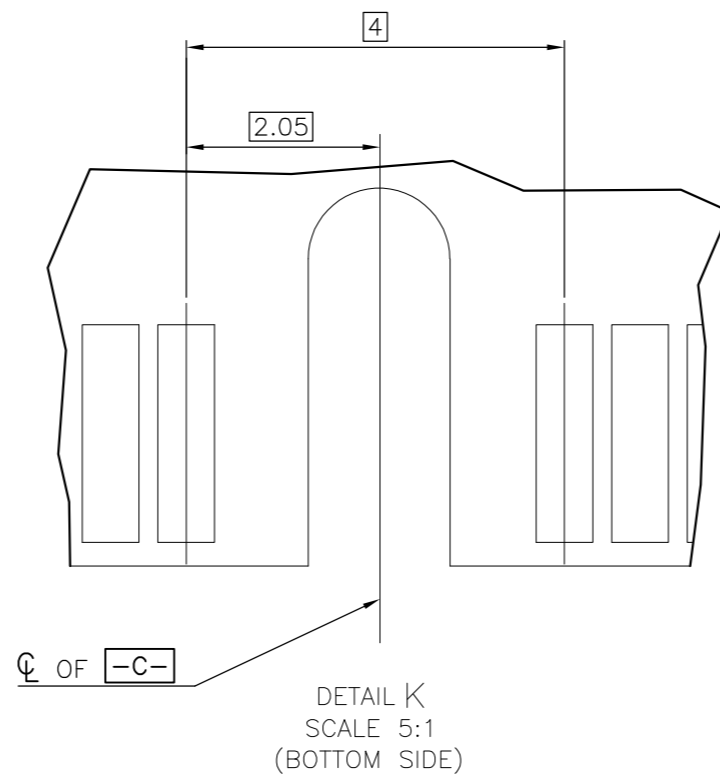
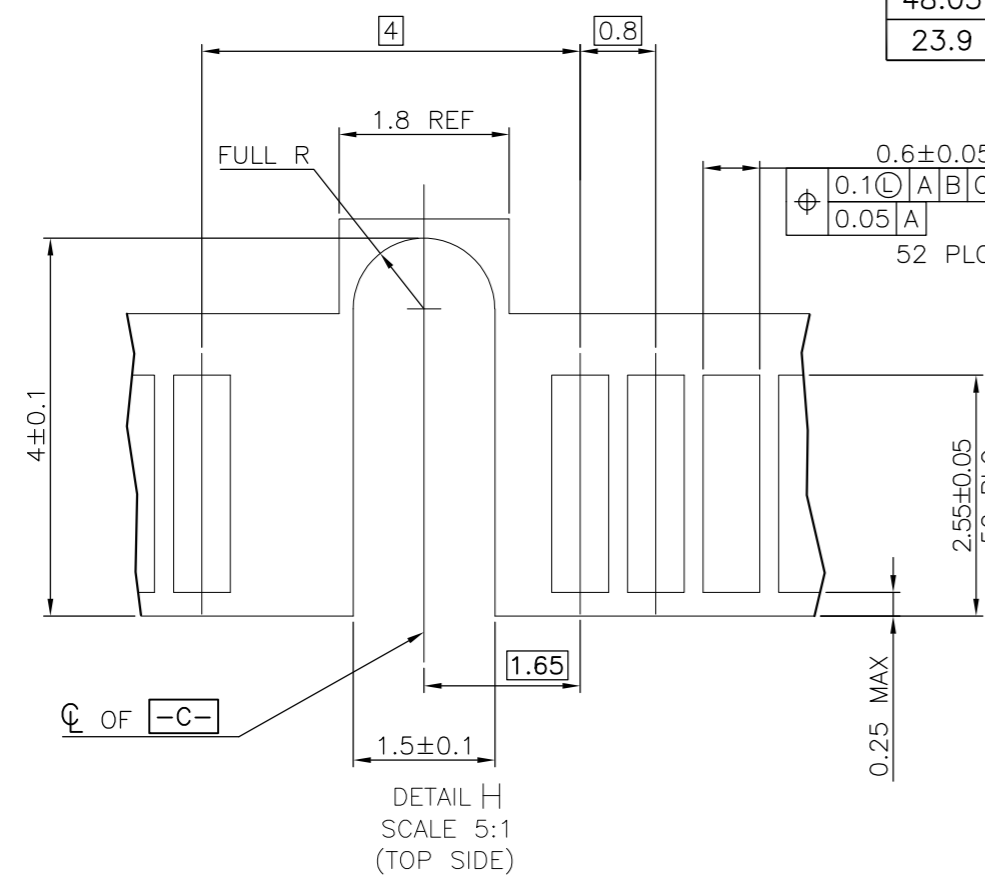

THIS DRAWING IS A CONTROLLED DOCUMENT.		DWN	31MAY2016		
DIMENSIONS: mm		CHK	-		
TOLERANCES UNLESS OTHERWISE SPECIFIED:		APVD	-	NAME	
0 PLC	± -	PRODUCT SPEC	-	2 IN 1 mSATA & PCI EXPRESS MINI CARD CONNECTOR, 7 MM HEIGHT	
1 PLC	± -	APPLICATION SPEC	-	SIZE	CAGE CODE
2 PLC	± -			A2	00779
3 PLC	± -			DRAWING NO	C=1759547
4 PLC	± -			RESTRICTED TO	-
ANGLES	± -	WEIGHT	-	SCALE	SHEET
FINISH	-	CUSTOMER DRAWING	-	-	3 OF 5
				REV	J

REVISIONS					
P	LTR	DESCRIPTION	DATE	DWN	APVD
J		SEE SHEET 1	-	-	-

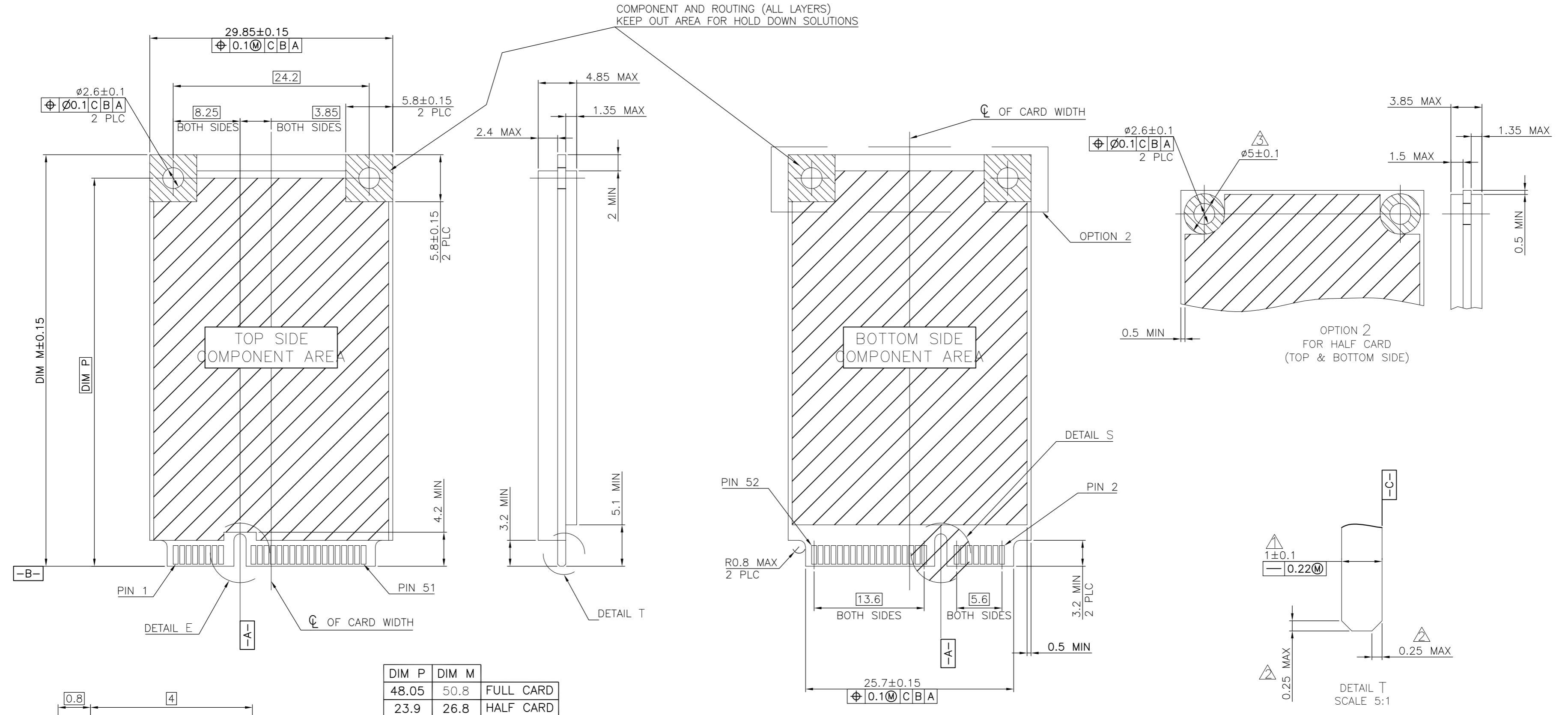

DIM P	DIM M	
48.05	50.8	FULL CARD
23.9	26.8	HALF CARD

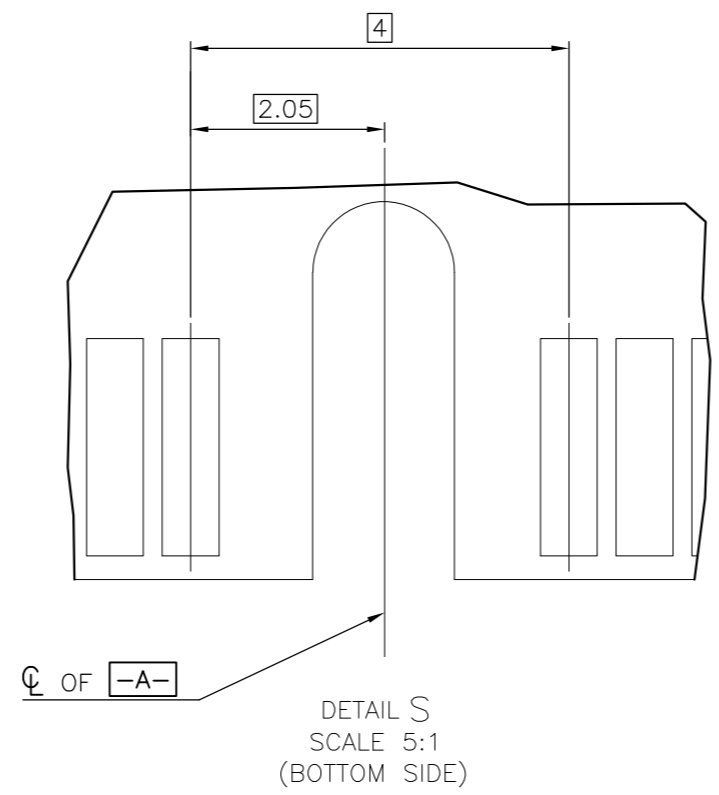
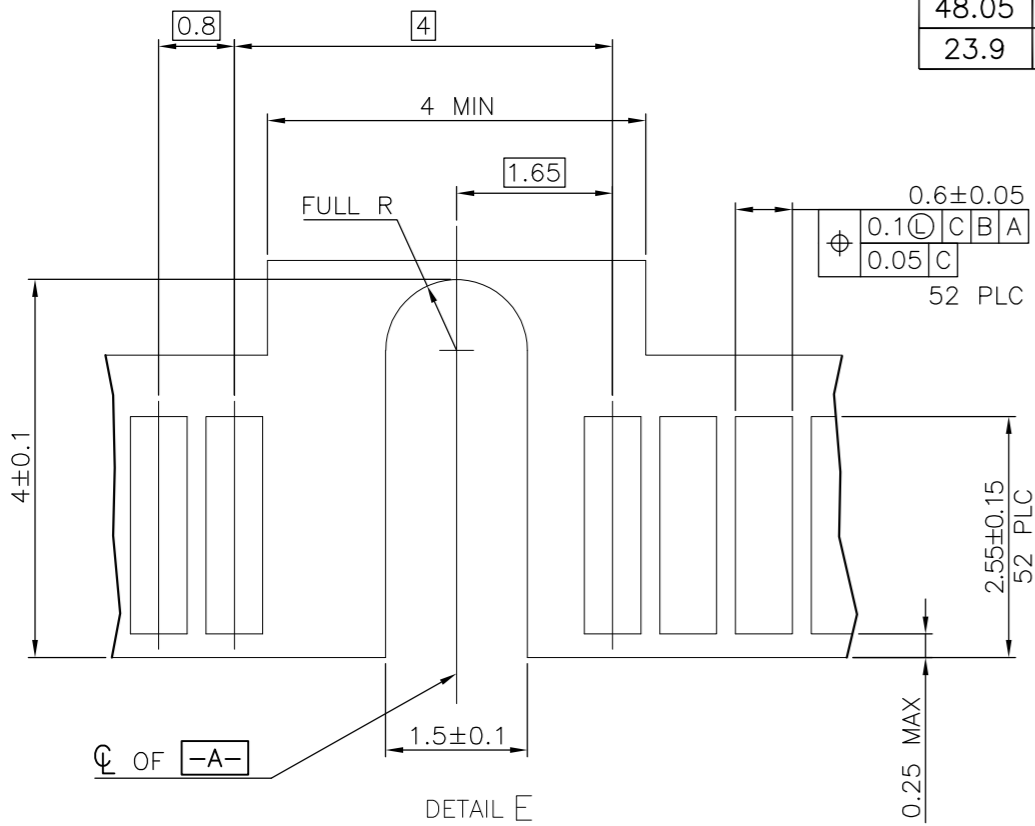

- NOTES:
- ▲ CARD THICKNESS APPLIES ACROSS TABS AND INCLUDES PLATING AND/OR METALLIZATION.
 - ▲ EDGE BEVEL MUST BE PRESENT AND FREE OF CUTTING BURRS FROM PCB AND CONTACT MATERIALS.
 - ▲ COMPONENT AND ROUTING (TOP/BOTTOM LAYER) KEEP OUT AREA FOR HOLD DOWN SOLUTIONS.

FOR mSATA

THIS DRAWING IS A CONTROLLED DOCUMENT.		DWN	31MAY2016	TE TE Connectivity	
DIMENSIONS: mm		CHK	-		
TOLERANCES UNLESS OTHERWISE SPECIFIED:		APVD	-	NAME	
0 PLC	± -	PRODUCT SPEC	-	2 IN 1 mSATA & PCI EXPRESS MINI CARD CONNECTOR, 7 MM HEIGHT	
1 PLC	± -	APPLICATION SPEC	-	SIZE	CAGE CODE
2 PLC	± -			A2	00779
3 PLC	± -			DRAWING NO	RESTRICTED TO
4 PLC	± -			C=1759547	-
ANGLES	± -	WEIGHT	-	SCALE	SHEET
FINISH	-	CUSTOMER DRAWING	-	-	4 OF 5
				REV	J

THIS DRAWING IS UNPUBLISHED. RELEASED FOR PUBLICATION
 © COPYRIGHT 2011 BY TE CONNECTIVITY. ALL RIGHTS RESERVED.

REVISIONS					
P	LTR	DESCRIPTION	DATE	DWN	APVD
J		SEE SHEET 1	-	-	-

NOTES:

- MATERIAL:
 BOX: FIBREBOARD, CORRUGATED, DOUBLE WALL.
 COVER TAPE: POLYSTYRENES, TRANSPARENT COLOR.
 CARRIER TAPE: POLYSTYRENES, TRANSPARENT COLOR.
 REEL: HIPS, BLUE COLOR.
 BAG: POLYETHYLENES, TRANSPARENT COLOR.
- EACH BAG SHALL BE INCLUDED DESICCANT.
- PEELING STRENGTH: 0.1 ~ 1.3 N (10 ~ 130 GRAMS).
- PEELING SPEED: 300 mm/min.

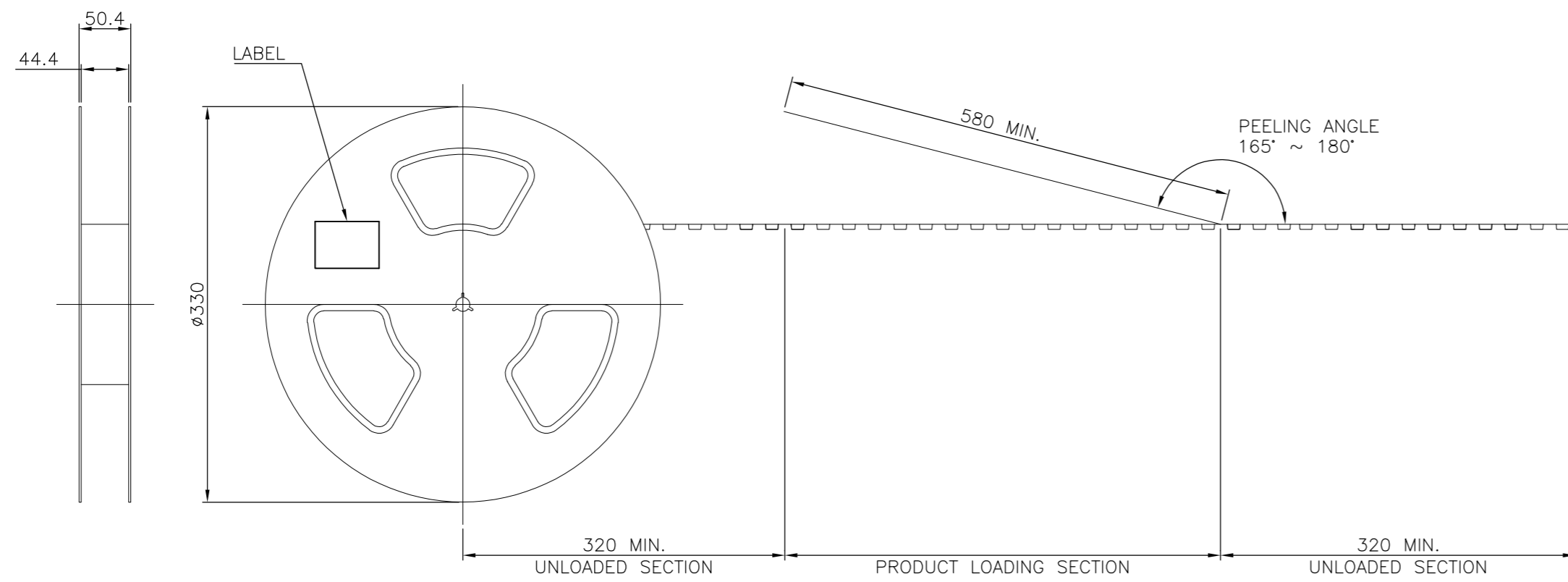

USER DIRECTION OF UNREELING

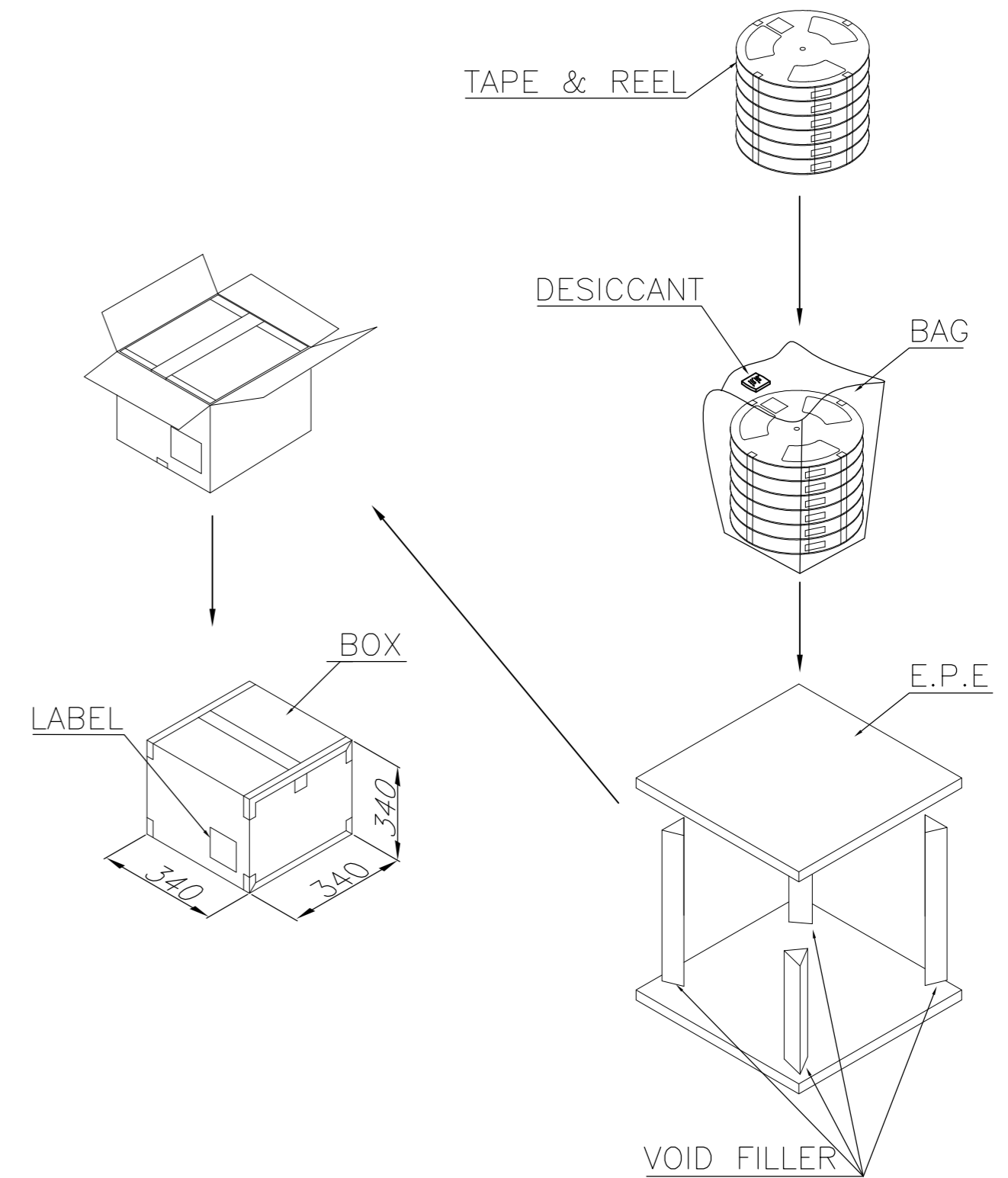
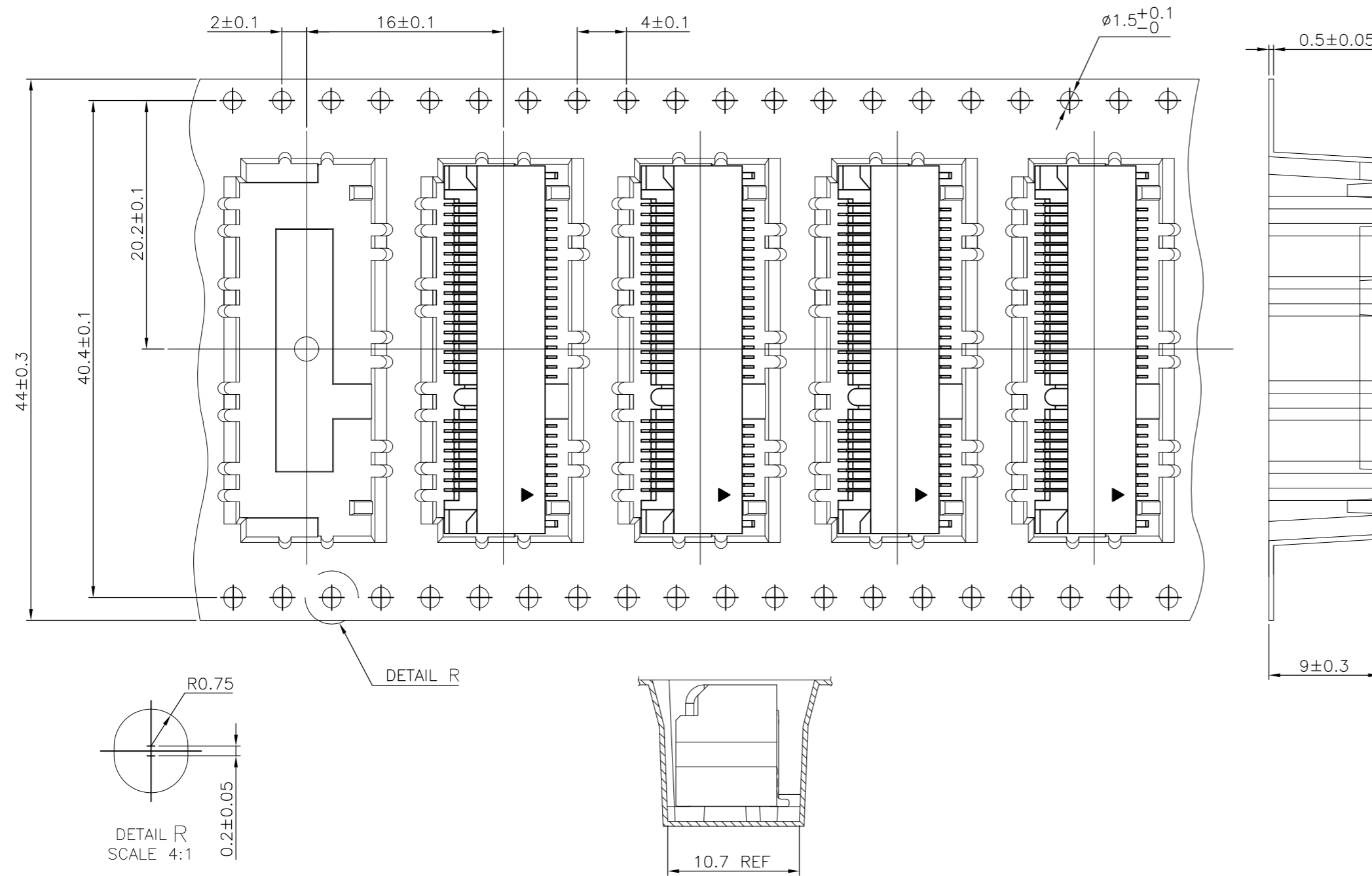

10.25 Kg	5.73 Kg	450	6	2700
GROSS WEIGHT	NET WEIGHT	PCS/TAPE	REELS/BOX	PCS/BOX

THIS DRAWING IS A CONTROLLED DOCUMENT.		DWN	31MAY2016	TE TE Connectivity	
DIMENSIONS: mm		CHK	-		
TOLERANCES UNLESS OTHERWISE SPECIFIED:		APVD	-	NAME	
0 PLC ± -		PRODUCT SPEC	-	2 IN 1 mSATA & PCI EXPRESS MINI CARD CONNECTOR, 7 MM HEIGHT	
1 PLC ± -		APPLICATION SPEC	-	SIZE	CAGE CODE
2 PLC ± -		WEIGHT	-	A2	00779
3 PLC ± -		CUSTOMER DRAWING	-	DRAWING NO	C=1759547
4 PLC ± -		SCALE	-	RESTRICTED TO	-
ANGLES ± -		SHEET	5 of 5	REV	J
FINISH		REV	-		