



Chipsmall Limited consists of a professional team with an average of over 10 year of expertise in the distribution of electronic components. Based in Hongkong, we have already established firm and mutual-benefit business relationships with customers from,Europe,America and south Asia,supplying obsolete and hard-to-find components to meet their specific needs.

With the principle of “Quality Parts,Customers Priority,Honest Operation,and Considerate Service”,our business mainly focus on the distribution of electronic components. Line cards we deal with include Microchip,ALPS,ROHM,Xilinx,Pulse,ON,Everlight and Freescale. Main products comprise IC,Modules,Potentiometer,IC Socket,Relay,Connector.Our parts cover such applications as commercial,industrial, and automotives areas.

We are looking forward to setting up business relationship with you and hope to provide you with the best service and solution. Let us make a better world for our industry!



## Contact us

Tel: +86-755-8981 8866 Fax: +86-755-8427 6832

Email & Skype: info@chipsmall.com Web: www.chipsmall.com

Address: A1208, Overseas Decoration Building, #122 Zhenhua RD., Futian, Shenzhen, China



## HC-D 7-KML/PG11/PA

Order No.: 1772308

<http://eshop.phoenixcontact.de/phoenix/treeViewClick.do?UID=1772308>

Coupling housing, with single locking latch, height 61 mm, with screw connection, 1x PG11, material PA

### Commercial data

EAN	4017918036973
Pack	10 pcs.
Customs tariff	85472000
Weight/Piece	0.03281 KG
Catalog page information	Page 509 (PC-2009)

### Product notes

WEEE/RoHS-compliant since:  
03/01/2006



<http://www.download.phoenixcontact.com>  
Please note that the data given here has been taken from the online catalog. For comprehensive information and data, please refer to the user documentation. The General Terms and Conditions of Use apply to Internet downloads.

### Technical data

#### General data

Note	For contact inserts HC-D7, D8, A3, A4, B5, HS2-D7
Design	D7
Height	61 mm
Width	26.5 mm
Length	26.5 mm
Housing type	Coupling housings
Locking type	With single locking latch
Type of the screw connection	1x Pg11
Pg screw connection	With

Wrench size, union nut	18 mm
External cable diameter	7.5 mm ... 12.5 mm
Degree of protection	IP54 / IP65 with sealing screw
Ambient temperature (operation)	-40 °C ... 125 °C
Housing material	PA
Housing surface material	PA, light gray
Cable gland material	PA
Cable seal material	NBR
Locking latch material	PA

### Certificates / Approvals



Certification GOST

### Accessories

Item	Designation	Description
------	-------------	-------------

#### Assembly

1686229	HC-D 7-DS-IP65	Sealing screw, for IP65 protection
---------	----------------	------------------------------------

### Diagrams/Drawings

Dimensioned drawing

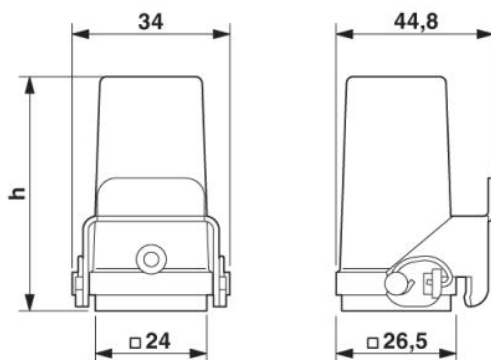

**Address**

PHOENIX CONTACT Inc., USA  
586 Fulling Mill Road  
Middletown, PA 17057, USA  
Phone (800) 888-7388  
Fax (717) 944-1625  
<http://www.phoenixcon.com>



© 2010 Phoenix Contact  
Technical modifications reserved;