



Chipsmall Limited consists of a professional team with an average of over 10 year of expertise in the distribution of electronic components. Based in Hongkong, we have already established firm and mutual-benefit business relationships with customers from,Europe,America and south Asia,supplying obsolete and hard-to-find components to meet their specific needs.

With the principle of “Quality Parts,Customers Priority,Honest Operation,and Considerate Service”,our business mainly focus on the distribution of electronic components. Line cards we deal with include Microchip,ALPS,ROHM,Xilinx,Pulse,ON,Everlight and Freescale. Main products comprise IC,Modules,Potentiometer,IC Socket,Relay,Connector.Our parts cover such applications as commercial,industrial, and automotives areas.

We are looking forward to setting up business relationship with you and hope to provide you with the best service and solution. Let us make a better world for our industry!



Contact us

Tel: +86-755-8981 8866 Fax: +86-755-8427 6832

Email & Skype: info@chipsmall.com Web: www.chipsmall.com

Address: A1208, Overseas Decoration Building, #122 Zhenhua RD., Futian, Shenzhen, China



HC-D 25-TFL-72/M1PG21G

Order No.: 1772450

The illustration shows version HC-D 25-TFL-72/M 1 PG 16 G



<http://eshop.phoenixcontact.de/phoenix/treeViewClick.do?UID=1772450>

Sleeve housing, for single locking latch, height 72 mm, with screw connection, 1x Pg21, straight cable entry

Commercial data

GTIN (EAN)	 4 017918 037123
sales group	D011
Pack	10 pcs.
Customs tariff	85389099
Catalog page information	Page 512 (PC-2009)

Product notes

WEEE/RoHS-compliant since:
02/22/2006



<http://www.download.phoenixcontact.com>
Please note that the data given here has been taken from the online catalog. For comprehensive information and data, please refer to the user documentation. The General Terms and Conditions of Use apply to Internet downloads.

Technical data

General data

Note	For contact inserts HC-D25, A16
Design	D25
Height	72 mm
Width	36 mm
Length	79.5 mm
Housing type	Sleeve housings
Locking type	for single locking latch
Cable exit	Straight
Type of the screw connection	1x Pg21
Pg screw connection	With
Wrench size, union nut	28 mm
External cable diameter	10 mm ... 19 mm
Degree of protection	IP65
Ambient temperature (operation)	-40 °C ... 125 °C
Housing material	Aluminum, die-cast
Housing surface material	Powder-coated, gray
Seal material	NBR
Cable gland material	Nickel-plated brass
Cable seal material	NBR

Certificates / Approvals



Certification

GOST

Diagrams/Drawings

Dimensioned drawing

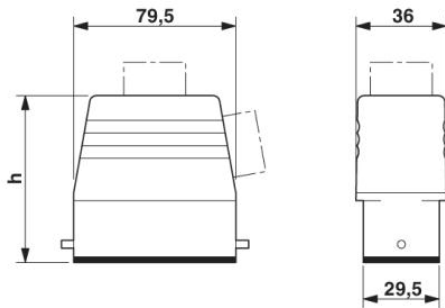

Address

PHOENIX CONTACT Inc., USA
586 Fulling Mill Road
Middletown, PA 17057, USA
Phone (800) 888-7388
Fax (717) 944-1625
<http://www.phoenixcon.com>



© 2010 Phoenix Contact
Technical modifications reserved;