



Chipsmall Limited consists of a professional team with an average of over 10 year of expertise in the distribution of electronic components. Based in Hongkong, we have already established firm and mutual-benefit business relationships with customers from,Europe,America and south Asia,supplying obsolete and hard-to-find components to meet their specific needs.

With the principle of “Quality Parts,Customers Priority,Honest Operation,and Considerate Service”,our business mainly focus on the distribution of electronic components. Line cards we deal with include Microchip,ALPS,ROHM,Xilinx,Pulse,ON,Everlight and Freescale. Main products comprise IC,Modules,Potentiometer,IC Socket,Relay,Connector.Our parts cover such applications as commercial,industrial, and automotives areas.

We are looking forward to setting up business relationship with you and hope to provide you with the best service and solution. Let us make a better world for our industry!



Contact us

Tel: +86-755-8981 8866 Fax: +86-755-8427 6832

Email & Skype: info@chipsmall.com Web: www.chipsmall.com

Address: A1208, Overseas Decoration Building, #122 Zhenhua RD., Futian, Shenzhen, China



HC-D 7-AML-24/GR

Order No.: 1773035

<http://eshop.phoenixcontact.de/phoenix/treeViewClick.do?UID=1773035>

HEAVYCON panel mounting base D7, with single locking latch, height 24 mm, straight, aluminum

Commercial data

EAN	4017918122324
Pack	10 pcs.
Customs tariff	85389099
Weight/Piece	0.04526 KG
Catalog page information	Page 509 (PC-2009)

Product notes

WEEE/RoHS-compliant since:
02/14/2006



<http://www.download.phoenixcontact.com>
Please note that the data given here has been taken from the online catalog. For comprehensive information and data, please refer to the user documentation. The General Terms and Conditions of Use apply to Internet downloads.

Technical data

General data

Note	For contact inserts HC-D7, D8, A3, A4, B5, HS2-D7
Design	D7
Height	24 mm

Width	38 mm
Length	28 mm
Housing type	Panel mounting base, straight
Locking type	With single locking latch
Degree of protection	IP54 / IP65 with sealing screw
Ambient temperature (operation)	-40 °C ... 125 °C
Housing material	Zinc die-cast
Housing surface material	Powder-coated, gray (metal housing)
Seal material	NBR
Locking latch material	Steel, galvanized
Single locking latch material	Zinc-plated steel and passivated
Length of the assembly cutout	21.5 mm
Width of the assembly cutout	21.5 mm

Certificates / Approvals



Certification GOST

Accessories

Item	Designation	Description
------	-------------	-------------

Assembly

1686229	HC-D 7-DS-IP65	Sealing screw, for IP65 protection
---------	----------------	------------------------------------

Diagrams/Drawings

Dimensioned drawing

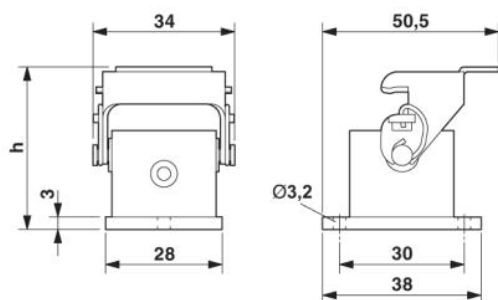

Address

PHOENIX CONTACT Inc., USA
586 Fulling Mill Road
Middletown, PA 17057, USA
Phone (800) 888-7388
Fax (717) 944-1625
<http://www.phoenixcon.com>



© 2010 Phoenix Contact
Technical modifications reserved;