



Chipsmall Limited consists of a professional team with an average of over 10 year of expertise in the distribution of electronic components. Based in Hongkong, we have already established firm and mutual-benefit business relationships with customers from,Europe,America and south Asia,supplying obsolete and hard-to-find components to meet their specific needs.

With the principle of “Quality Parts,Customers Priority,Honest Operation,and Considerate Service”,our business mainly focus on the distribution of electronic components. Line cards we deal with include Microchip,ALPS,ROHM,Xilinx,Pulse,ON,Everlight and Freescale. Main products comprise IC,Modules,Potentiometer,IC Socket,Relay,Connector.Our parts cover such applications as commercial,industrial, and automotives areas.

We are looking forward to setting up business relationship with you and hope to provide you with the best service and solution. Let us make a better world for our industry!



Contact us

Tel: +86-755-8981 8866 Fax: +86-755-8427 6832

Email & Skype: info@chipsmall.com Web: www.chipsmall.com

Address: A1208, Overseas Decoration Building, #122 Zhenhua RD., Futian, Shenzhen, China



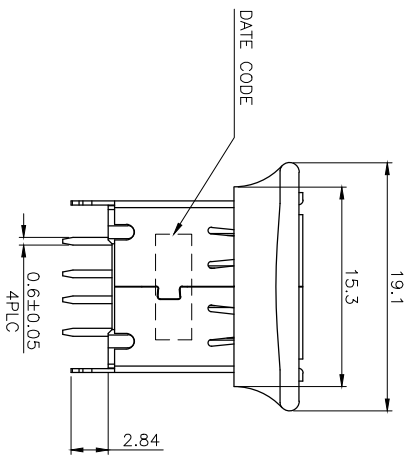
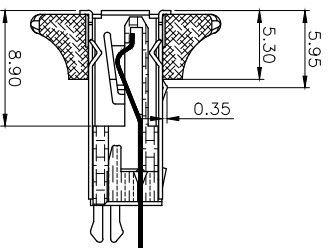
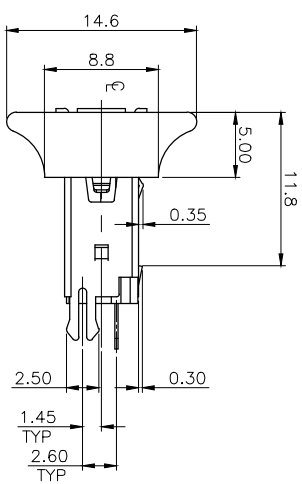
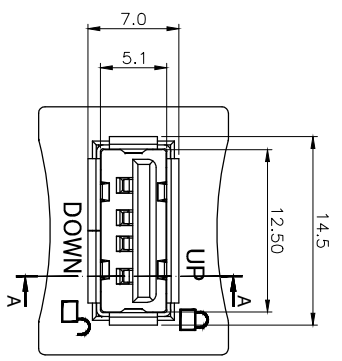
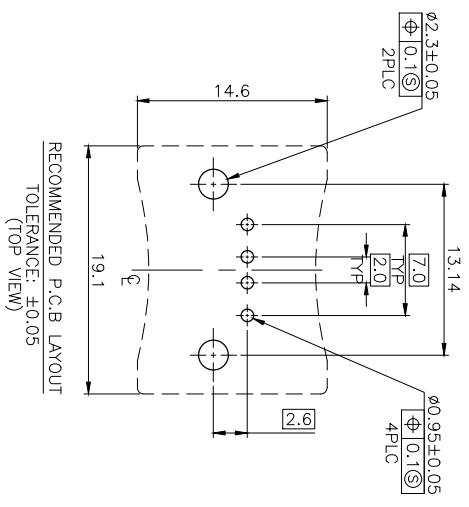
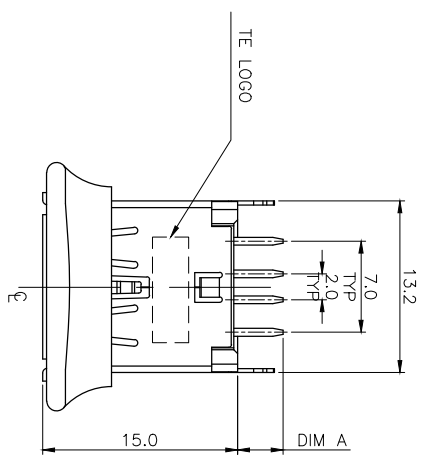

LOC	DIST	REV	DATE	DMN	APVD
DW	-	P			
		LTR			
		A3	REVISED (EGR-14-005336)	21MAR14	SW SC

- NOTES:
- MATERIAL:
HOUSING: PART WITH 30% GF, UL94V-0, COLOR: BLACK.
LOCKING DEVICE: PA66 WITH 15% GF, UL94V-0, COLOR: BLUE (IBM COLOR WHEEL P/N: 49Y5681, PANTONE COLOR SIMILAR TO 2718U).
CONTACTS: PHOSPHOR BRONZE, T=0.25mm.
SHELL: BRASS, T=0.30mm.
 - FINISH:
CONTACTS: GOLD (SEE TABLE) PLATED ON CONTACT AREA, 2.54um (100u") MIN. BRIGHT-TIN PLATING ON SOLDER TAILS, 1.27um (50u") MIN. NICKEL UNDERPLATED ALL OVER.
SHELL: 1.27um (50u") MIN. NICKEL PLATED.
 - RECOMMENDED PCB THICKNESS: 1.6mm.
 - WAVE SOLDER CAPABLE TO 265°C PER TE CONNECTIVITY TEST SPEC, 109-202.CONDITION B.

EOL	2.84	0.762um (30u")	1-1775690-2
EOL	2.84	G/F	1-1775690-1
EOL	3.50	0.762um (30u")	1775690-2
EOL	3.50	G/F	1775690-1
DIM A		MIN. GOLD	PART NUMBER

STE TE Connectivity
USB A TYPE, W/LOCKING
VERTICAL, DIP

THIS DRAWING IS A CONTROLLED DOCUMENT.		NAME	
DMN	H. HUANG	19JUL2007	
CHK	S. HOU	19JUL2007	
APVD	W. KE	19JUL2007	
PRODUCT SPEC	108-57519		
QUALIFICATION TEST REPORT	501-57772		
WEIGHT	2.9 GRAMS	SIZE	A3
CUSTOMER DRAWING		DWG CODE	00779
		DRAWING NO	1775690
		SCALE	1 OF 2
		SHEET	REV A3



DIMENSIONS:	TOLERANCES UNLESS OTHERWISE SPECIFIED:
MM	± -
0 PLC	± 0.30
1 PLC	± 0.25
2 PLC	± -
3 PLC	± -
4 PLC	± .3°

MATERIAL SEE NOTE
FINISH SEE NOTE

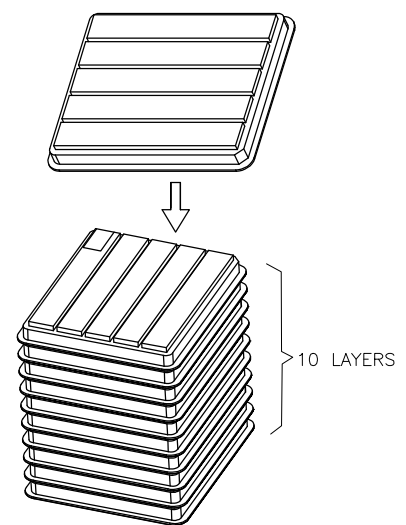
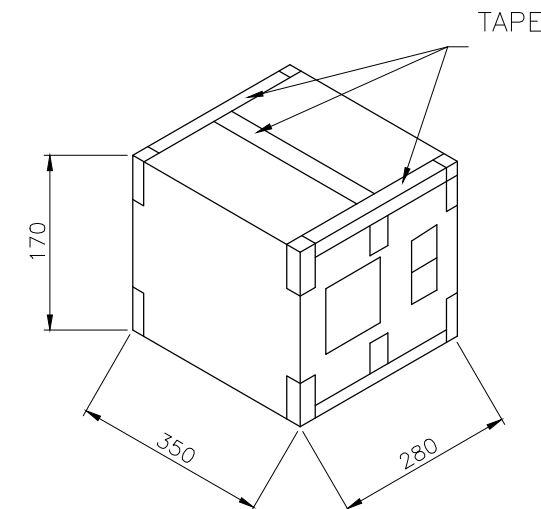
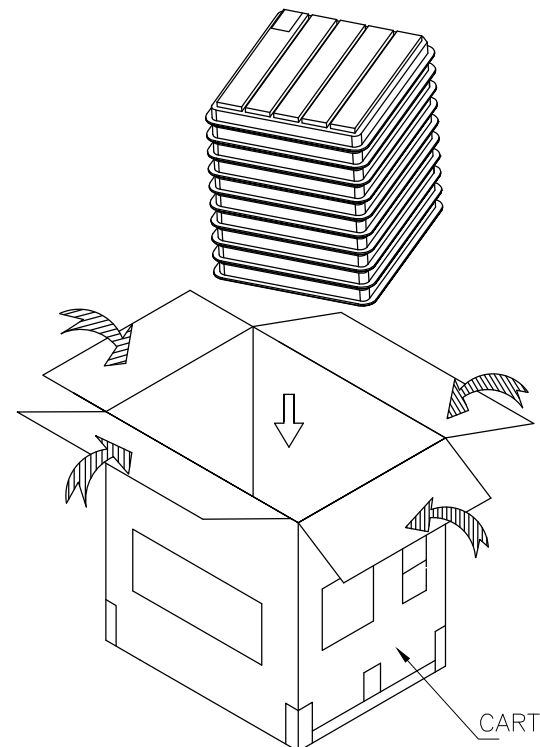
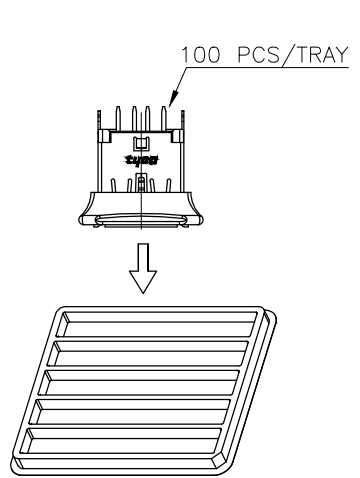
LOC	DIST	REVISIONS					
DW	-	P	LTR	DESCRIPTION	DATE	DWN	APVD
				SEE SHEET 1.			



100	10	1000	3.9	2.9
PCS/ TRAY	TRAY/ CARTON	QUANTITY	G/W (KG)	N/W (KG)

THIS DRAWING IS A CONTROLLED DOCUMENT.		DWN H. HUANG 19JUL2007	 TE Connectivity		
DIMENSIONS: MM		CHK S. HOU 19JUL2007			NAME
		APVD W.J. KE 19JUL2007			
TOLERANCES UNLESS OTHERWISE SPECIFIED:		PRODUCT SPEC	USB A TYPE, W/LOCKING VERTICAL, DIP		
0 PLC ± - 1 PLC ± - 2 PLC ± - 3 PLC ± - 4 PLC ± - ANGLES ± -		APPLICATION SPEC	SIZE	RESTRICTED TO	
MATERIAL		WEIGHT	CAGE CODE		
FINISH		DRAWING NO			
		A3 00779 C=1775690			
		CUSTOMER DRAWING		SCALE	
				SHEET	
				2 of 2	
				REV	
				A3	