



Chipsmall Limited consists of a professional team with an average of over 10 year of expertise in the distribution of electronic components. Based in Hongkong, we have already established firm and mutual-benefit business relationships with customers from,Europe,America and south Asia,supplying obsolete and hard-to-find components to meet their specific needs.

With the principle of “Quality Parts,Customers Priority,Honest Operation,and Considerate Service”,our business mainly focus on the distribution of electronic components. Line cards we deal with include Microchip,ALPS,ROHM,Xilinx,Pulse,ON,Everlight and Freescale. Main products comprise IC,Modules,Potentiometer,IC Socket,Relay,Connector.Our parts cover such applications as commercial,industrial, and automotives areas.

We are looking forward to setting up business relationship with you and hope to provide you with the best service and solution. Let us make a better world for our industry!



Contact us

Tel: +86-755-8981 8866 Fax: +86-755-8427 6832

Email & Skype: info@chipsmall.com Web: www.chipsmall.com

Address: A1208, Overseas Decoration Building, #122 Zhenhua RD., Futian, Shenzhen, China



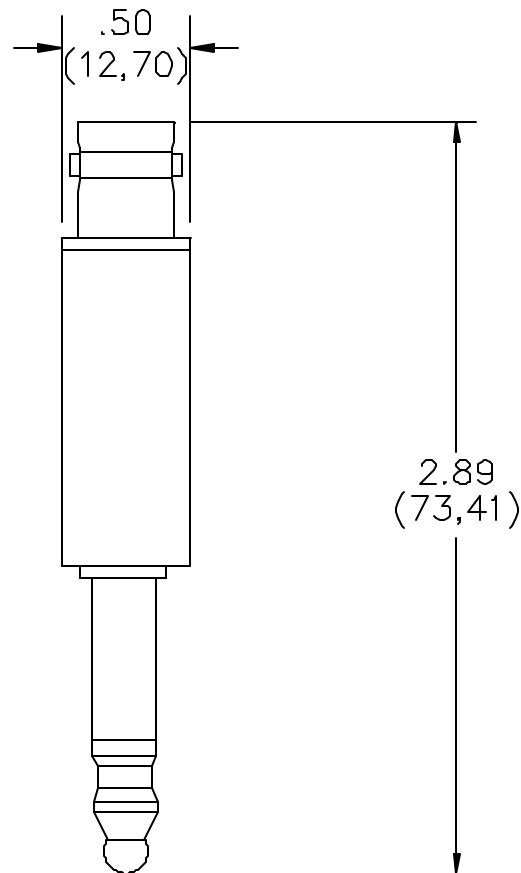

FEATURES:

- Permits BNC male to be used with equipment having three circuit phone jacks.
- Readily adapts equipment to available BNC coaxial cable.
- Tip connected to inner contact of connector and ring connected to shell.
- Sleeve, no connection.

MATERIALS:

Upper Conn: BNC Female

Finish: Body – Tarnish Resistant.

Center Contact – Gold plated Beryllium Copper per MIL-C-39012

Marking: “026-001-008”

Insulation: ABS molded to BNC Female and Phone Plug.

Color: Black

Marking: “POMONA ELECTRONICS
MODEL 1794”

Lower Conn: Phone Plug PJ-068

Brass (Equivalent to WE-309)

RATINGS:

Operating Temperature: +50°C (+122°F) Max.

Operating Voltage: 500 V Peak

ORDERING INFORMATION: Model 1794

All dimensions are in inches. Tolerances (except noted): .xx = ±.02” (.51 mm), .xxx = ± .005” (.127 mm).
All specifications are to the latest revisions. Specifications are subject to change without notice.
Registered trademarks are the property of their respective companies.

Made in USA