



Chipsmall Limited consists of a professional team with an average of over 10 year of expertise in the distribution of electronic components. Based in Hongkong, we have already established firm and mutual-benefit business relationships with customers from,Europe,America and south Asia,supplying obsolete and hard-to-find components to meet their specific needs.

With the principle of “Quality Parts,Customers Priority,Honest Operation,and Considerate Service”,our business mainly focus on the distribution of electronic components. Line cards we deal with include Microchip,ALPS,ROHM,Xilinx,Pulse,ON,Everlight and Freescale. Main products comprise IC,Modules,Potentiometer,IC Socket,Relay,Connector.Our parts cover such applications as commercial,industrial, and automotives areas.

We are looking forward to setting up business relationship with you and hope to provide you with the best service and solution. Let us make a better world for our industry!



## Contact us

Tel: +86-755-8981 8866 Fax: +86-755-8427 6832

Email & Skype: info@chipsmall.com Web: www.chipsmall.com

Address: A1208, Overseas Decoration Building, #122 Zhenhua RD., Futian, Shenzhen, China



REVISIONS			
REV	ECN, ERN NO.	DATE	APPRD.
A	PRODUCT DRAWING (EAR 13158)	OCT23/07	K.L.

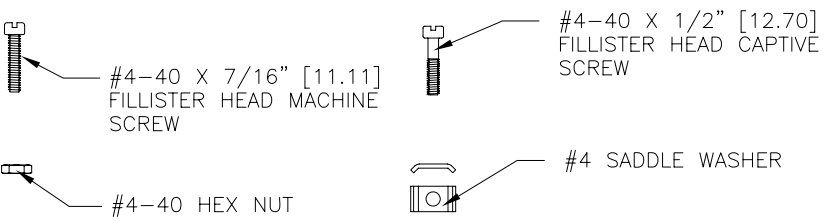
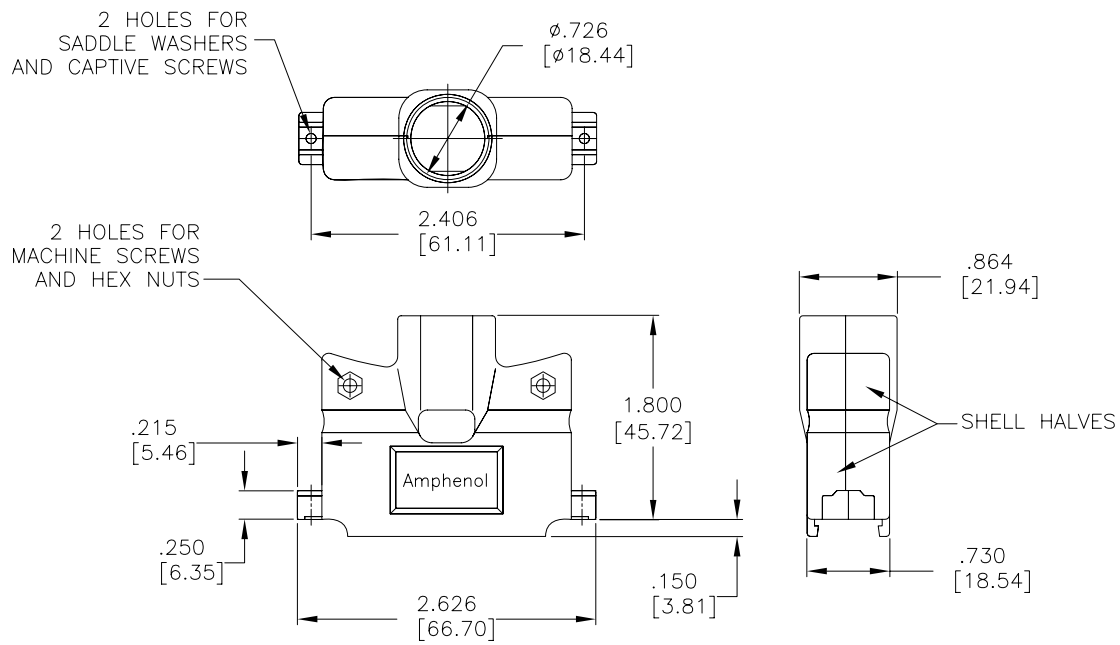

- NOTES:
- EACH BACKSHELL KIT CONTAINS 2 SHELL HALVES, 1 COMPRESSION INSERT TREE AND 2 OF EACH HARDWARE ITEM SHOWN.
  - BACKSHELL IS SUITABLE FOR SUBMINIATURE D CONNECTOR, D SIZE SHELL (50 POSITION STANDARD CONTACTS OR 78 POSITION HIGH DENSITY CONTACTS).
  - COMPRESSION JACKET INSERTS ARE DESIGNED FOR A CABLE DIAMETER RANGE OF .350 [8.89] TO .650 [16.51].
  - MATERIALS - ALL MATERIALS ARE RoHS COMPLIANT  
SHELL - ZINC ALLOY, ZINC PLATED, HEXAVALENT CHROMIUM FREE FINISH.  
INSERT TREE - BLACK THERMOPLASTIC, 75 DUROMETER  
HARDWARE - STEEL, ZINC PLATED, HEXAVALENT CHROMIUM FREE FINISH

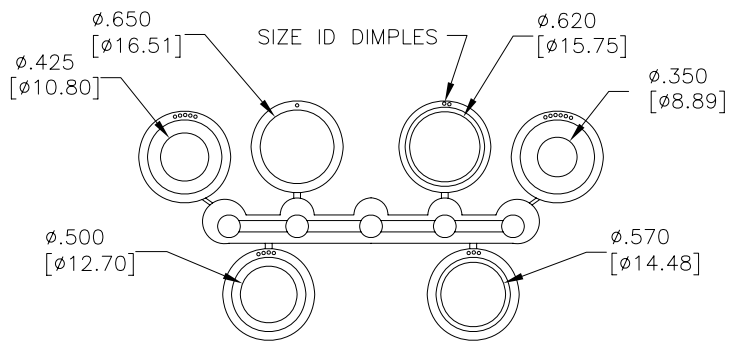

COMPRESSION INSERT TREE

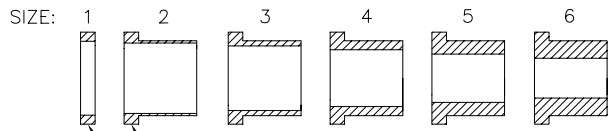

WASHER OR WASHER PORTION OF INSERT

- ASSEMBLY INSTRUCTIONS:
- SELECT THE TIGHTEST INSERT THAT WILL FIT OVER THE CABLE, AND FEED THE CABLE THROUGH IT, PLACING THE END WITH THE SMALLER OD (THE END WITHOUT THE WASHER) TOWARDS THE CONNECTOR.
  - TERMINATE THE CABLE WIRES TO THE CONNECTOR.
  - CUT THE JACKET, FOLD THE SHIELDING BACK OVER THE OUTSIDE OF THE INSERT AND CUT IT JUST SHORT OF THE WASHER.
  - INSTALL SADDLE WASHERS, CAPTIVE SCREWS AND CONNECTOR.
  - PLACE THE WASHER IN OUTERMOST DEPRESSION IN CABLE EXIT AREA OF THE BACKSHELL AND SCREW SHELL HALVES CLOSED.



AMPHENOL PART NUMBER 17E-1657-50

DRAWN J. WOOD		DATE SEP28/07		Amphenol Canada Corp.			
DESIGNED							
CHECKED K. LAMBIE		DATE OCT23/07		17E SERIES METAL BACKSHELL FOR D-SUB CONNECTOR WITH D SIZE SHELL (50 STD OR 78 HD CONTACTS), STRAIGHT EXIT, #4-40 THREAD, RoHS COMPLIANT			
I. E. APPRD.							
Q. A. APPRD.							
DWG. APPRD.							
ENG. REL. NO. EAR 13158		DWG. B		DRAWING NO. P-17E-1657-50		REV. A	
REF.		DIMENSIONS ARE IN INCHES [mm]		CODE ID. NO. 03554		SCALE 1/1	
				WT. -----		SURF. -----	
						SHEET 1 OF 1	

THIS DOCUMENT CONTAINS PROPRIETARY INFORMATION AND SUCH INFORMATION MAY NOT BE DISCLOSED TO OTHERS FOR ANY PURPOSE OR USED FOR MANUFACTURING PURPOSES WITHOUT WRITTEN PERMISSION FROM AMPHENOL CANADA CORP.