



Chipsmall Limited consists of a professional team with an average of over 10 year of expertise in the distribution of electronic components. Based in Hongkong, we have already established firm and mutual-benefit business relationships with customers from,Europe,America and south Asia,supplying obsolete and hard-to-find components to meet their specific needs.

With the principle of "Quality Parts,Customers Priority,Honest Operation,and Considerate Service",our business mainly focus on the distribution of electronic components. Line cards we deal with include Microchip,ALPS,ROHM,Xilinx,Pulse,ON,Everlight and Freescale. Main products comprise IC,Modules,Potentiometer,IC Socket,Relay,Connector.Our parts cover such applications as commercial,industrial, and automotives areas.

We are looking forward to setting up business relationship with you and hope to provide you with the best service and solution. Let us make a better world for our industry!



Contact us

Tel: +86-755-8981 8866 Fax: +86-755-8427 6832

Email & Skype: info@chipsmall.com Web: www.chipsmall.com

Address: A1208, Overseas Decoration Building, #122 Zhenhua RD., Futian, Shenzhen, China



Description

Module 17plus is a mounting and power distribution system for use with the following plug-in type devices:

- **Circuit breakers type 2210-S, 3600, 3900**
- **Electronic circuit breakers and protectors type ESS20, ESX10, ESX10-S**
- **Solid state remote power controller E-1048-S7...**

Each module accommodates two breakers with an individual housing width of 12.5 mm and fits onto all industry standard mounting rails. The two-way modules are mounted side-by-side to provide as many ways as required with a terminal block fitted at each end for connection of signalling circuits. Electrical connections are by means of screwless spring-loaded terminals. Fitting a busbar on the terminal side of the modules provides power distribution onto the individual ways with a common line entry. When plugging in multipole circuit breakers, the busbar cannot be used. In this case each pole has to be individually connected. All internal wirings for the ground potential and the group signal are established by the side-by-side mounting of the individual modules (centre pieces, terminal blocks). The suitable circuit breakers or SSRPCs have integral signal contacts (break and make contacts). Depending on the application they can be used for single or group signalling. When using multipole breakers, auxiliary contacts are required in each pole so as not to interrupt the current loop of the group signalling by missing auxiliary contacts.

Fitted with 2210-S:

The integral auxiliary contacts of thermal-magnetic circuit breaker type 2210-S (make and break) can be used for single or group signalling, depending on the application. For group fault signalling all required terminals (make contacts, they open in the event of a failure) within the Module 17plus are connected in series. Group signalling is realised via the terminals on the side (13, 14). Single signalling requires connection of the break contacts (they close in the event of a failure). In this case one side of the contacts in the modules is connected in parallel (pin 11). The second contact side is accessible per module way and can be connected via terminal (pin 12). Both types of signalling are available at the same time, if the circuit breaker type used has auxiliary contacts (please note when ordering).

Fitted with 3600/3900:

The integral auxiliary contacts of thermal-magnetic circuit breaker types 3600/3900 (make and break) can be used for single or group signalling, depending on the application. For group fault signalling all required terminals (make contacts, they open in the event of a failure) within the Module 17plus are connected in series. Group signalling is realised via the terminals on the side (13, 14). Single signalling requires connection of the break contacts (they close in the event of a failure). In this case one side of the contacts in the modules is connected in parallel (pin 11). The second contact side is accessible per module way and can be connected via terminal (pin 12). Both types of signalling are available at the same time.

Fitted with ESS20-0:

The reference potential for the ESS20-0.. (Gnd pin 11) is also looped through and connected to the terminal elements at the sides. All internal wirings for the ground potential and the group signal are established by the side-by-side mounting of the individual modules (centre pieces, terminal blocks). The integral make contact of the ESS20-001 (SC-SI) can be tapped at terminal 12 of the relevant channel (single signalling). The integral break contact can be tapped at terminal 12 of the relevant channel (single signalling). The ESS20-003 features an integral auxiliary contact (change-over). The contact SC-SO is used for the group fault indication. For this type of signalling, all contacts in the Modules 17plus are connected in series and are connected via two terminals (13, 14) to the terminals blocks on either side. It is possible with a test probe to contact the series connection in each module and detect possible interruptions.



17plus

Fitted with ESS20-1:

The reference potential for the ESS20-1.. (Gnd pin 11) is also looped through and connected to the terminal elements at the sides. The integral signal output SF of the ESS20-124 can be tapped at terminal 12 of the relevant channel (single signalling). The reset input RE can be connected via terminal 13 or 14.

Fitted with ESS30-S:

The reference potential for the ESS30-S.. (Gnd pin 11) is also looped through and connected to the terminal elements at the sides. All internal wirings for the ground potential and the group signal are established by the side-by-side mounting of the individual modules (centre pieces, terminal blocks). The ESS30-S003 features an integral auxiliary contact (change-over). The contact SC-SO is used for the group fault indication. For this type of signalling, all contacts in the Modules 17plus are connected in series and are connected via two terminals (13, 14) to the terminals blocks on either side. It is possible with a test probe to contact the series connection in each module and detect possible interruptions.

Fitted with ESX10/ESX10-S:

The reference potential for the ESX10 (Gnd pin 11) is also looped through and connected to the terminal elements at the sides. The integral signal output SF of the ESX10-124/-S124 can be tapped at terminal 12 of the relevant channel (single signalling). The inverted status output SF can also be tapped at terminal 12 of the corresponding channel. The reset input RE can be connected via terminal 13 or 14 (ESX10-124/S124/-127/-S127) or terminal 12 (ESX10-125/-S125). The integral control input IN+ of type ESX10-115/-S115 is fed in via terminal 12. Depending on the option, a potential-free auxiliary contact is also available (ESX10-103/-115/-125/-S103/-S115/-S125).

Fitted with E-1048-S7xx:

The reference potential for the ESS20-0.. (Gnd pin 11) is also looped through and connected to the terminal elements at the sides. Actuation of the SSRPC (IN+), referenced to GND, is via the separate terminal 12 per way beside the LOAD terminal. The SSRPC has an integral auxiliary contact (break contact) used for group fault signalling. For this type of signalling, all contacts in the Modules 17plus are connected in series and are connected via two terminals (13, 14) to the terminals blocks on either side. It is possible with a test probe to contact the series connection in each module and detect possible interruptions. All internal wirings for the ground potential and the group signal are established by the side-by-side mounting of the individual modules.

Technical data

Connection	Spring-loaded terminals for rigid wires or flexible cables with unisolated wire end ferrules or without wire end ferrules. Please use appropriate screw driver size (SD) for removing the spring loaded terminals.		
cable	cross section of connecting cable	screw driver	stripped length
Line feed (1.1/ 1.2)	1.5-10 mm ²	3 (1.0 x 5.5)	12 mm
Load output (2.1/2.2)	0.25-4 mm ²	1 (0.6 x 3.5)	12 mm
Signalisation terminals (11, 13, 14)	0.25-2.5 mm ²	1 (0.6 x 3.5)	10 mm
Signalisation terminal (12.1/12.2)	0.25-1.5 mm ²	0 (0.4 x 2.5)	9 mm
Diameter of test socket	ø ≤ 2 mm		
Voltage rating (without circuit breaker)	AC 250 V; 3 AC 433 V; DC 65 V		
with 2210-S:	AC 250 V; 3 AC 433 V; DC 65 V		
with 3600/3900:	AC 240 V (50/60 Hz); DC 65 V		
with ESS20:	18 V...32 V DC		
with ESX10/ESX10-S:	18 V...32 V DC		
with E-1048-S7..:	18 V...36 V DC		
Current rating (without circuit breaker)			
Line feed (1.1/1.2)	50 A		
Load output (2.1/2.2)	25 A		
Signalisation Feed (11) (ground with electronic components)	10 A		
Single output (12.1/12.2)	1 A (with ESS20/ESX10: 0,5 A)		
Group signal (13-14)	1 A (with ESS20/ESX10: 0,5 A)		
Caution: When several devices are mounted together, each should carry only max. 80 % ($I_N \leq 16 A$) or max. 65 % ($I_N > 16 A$) of its rating.			
Internal resistances (without circuit breaker)			
Line/load (1.1-2.1)	≤ 5 mΩ		
Signalisation	≤ 9 mΩ (+ 2 mΩ per additional module)		
Group signal (13-14)	≤ 8 mΩ (+ 5 mΩ per additional module)		
Vibration	5 g (57-500 Hz) ± 0,38 mm (10-57 Hz); to IEC 60068-2-6, test Fc, 10 frequency cycles/axis		
Shock	25 g (11 ms) to IEC 60068-2-27, test Ea 11 ms half sine		
Corrosion	96 hours at 5 % salt mist, to IEC 60068-2-11, test Ka		
Humidity	240 hours at 95 % RH to IEC 60068-2-78, test Cab		
Dielectric strength			
between main circuits (without busbar):	1 500 V		
main circuit to auxiliary circuit:	1 500 V		
between auxiliary circuits:	1 500 V (without circuit breaker)		
Mass			
Module 17plus (centre piece)	approx. 85 g		
terminal blocks (pair)	approx. 30 g		

Approvals

Authority	Standard	Rated voltage	Current ratings
UL	UL 60950	AC 250 V DC 80 V	25 A per channel 25 A per channel

Ordering information

17PLUS-Q02-00	Module 17plus, centre piece
17PLUS-QA0-LR	two-way one each left- and right-side terminal block for supply feed from the side by means of screw terminal

For technical data of

Circuit Breaker 2210-S, 3600, 3900

please see chapter Thermal-magnetic circuit breakers

Electronic Circuit Breaker ESS20, ESS30-S, ESX10, ESX10-S
please see chapter Electronic overcurrent protection

Solid State Remote Power Controller E-1048-S7..
please see chapter Power distribution systems

Installation example (with type 2210)

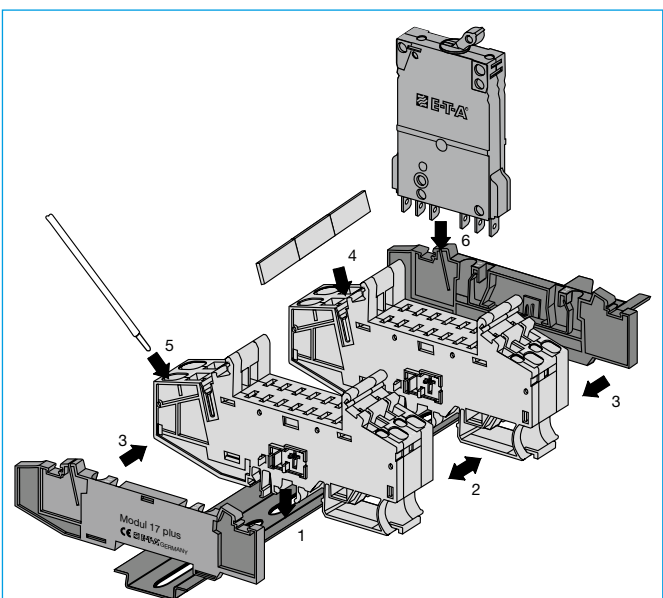

Installation:

- 1 Clip modules onto DIN rails.
- 2 Push modules together (side-by-side).
- 3 Snap on right-side and left-side terminal blocks.
- 4 Cut busbar to required length and fit on supply side of the modules.
- 5 Connect line feed with spring-loaded terminals.
- 6 Plug in circuit breakers.

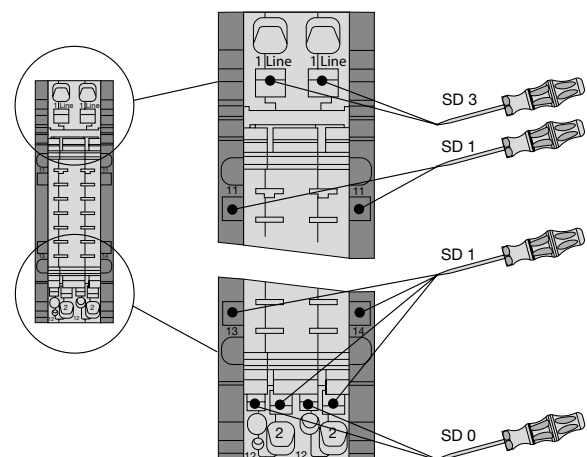

Connection and disconnection of cables with screw driver

Dimensions (with type 2210)

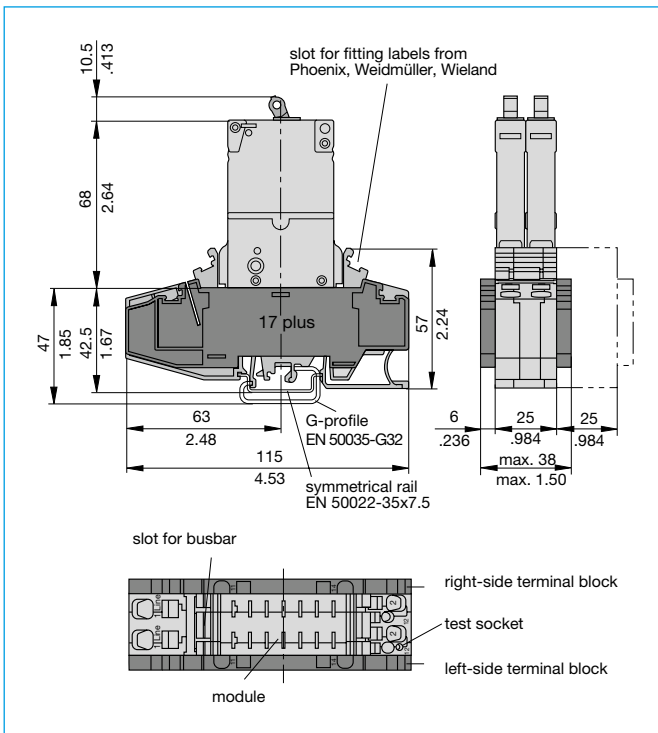

Dimensions (with type 3600/3900)

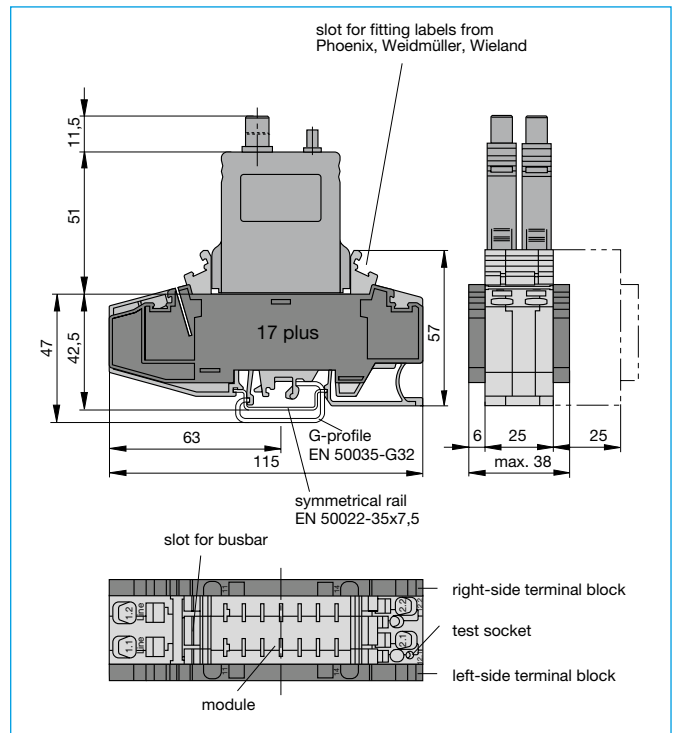

Connection diagram 2210-S

Example for circuit breaker types 2210

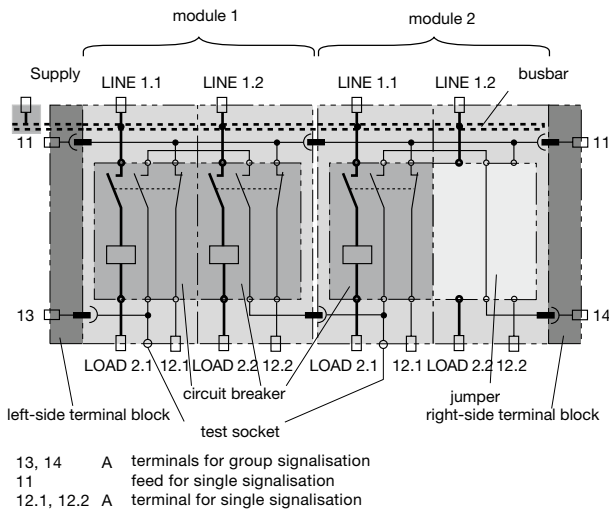

Connection diagram 3600/3900

Example for circuit breaker types 3600/3900

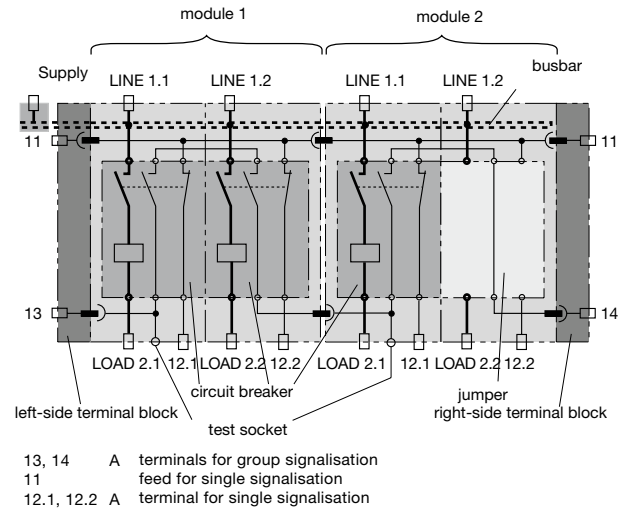

Pin selection, fitted with 2210-S..

2210-S.. Module 17plus

Pin	Module 17plus	Diagram
1	(1.1, 1.2)	
11	(11)	
23	(13)	
24	(14)	
12	(12.1, 12.2)	
2	(2.1, 2.2)	

Pin selection, fitted with 3600/3900

3600/3900 Module 17plus

Pin	Module 17plus	Diagram
1	(1.1, 1.2)	
4	(11)	
6	(13)	
3 (N.C.)		
7	(14)	
5	(12.1, 12.2)	
2	(2.1, 2.2)	

Dimensions (with type ESS20)

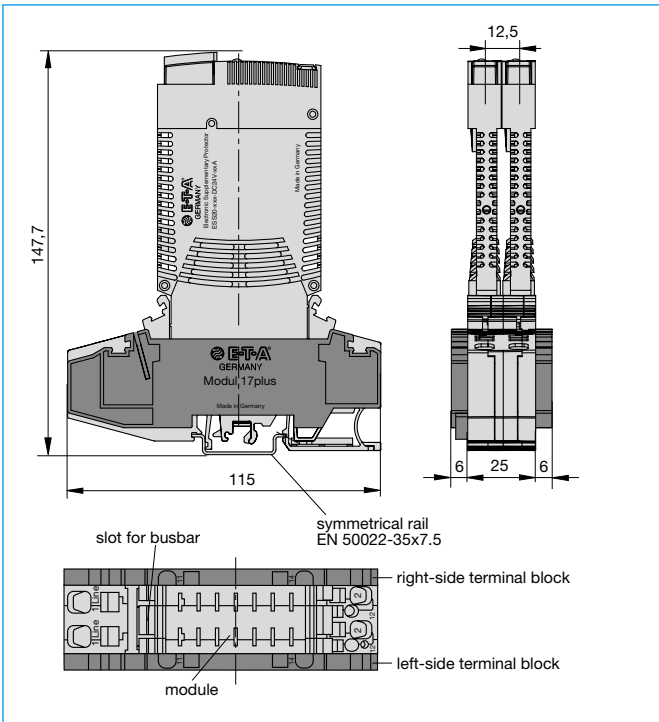

Connection diagram ESS20-001

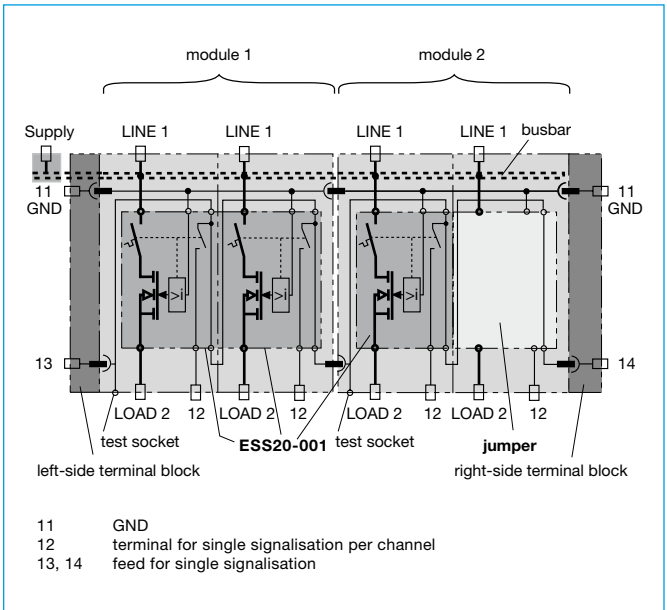

Pin selection, fitted with ESS20-0..

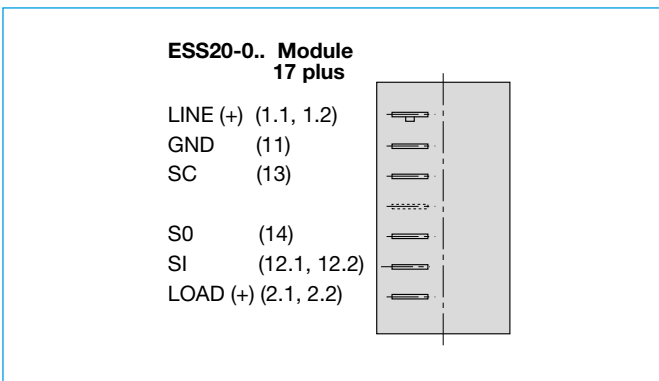

Connection diagram ESS20-003

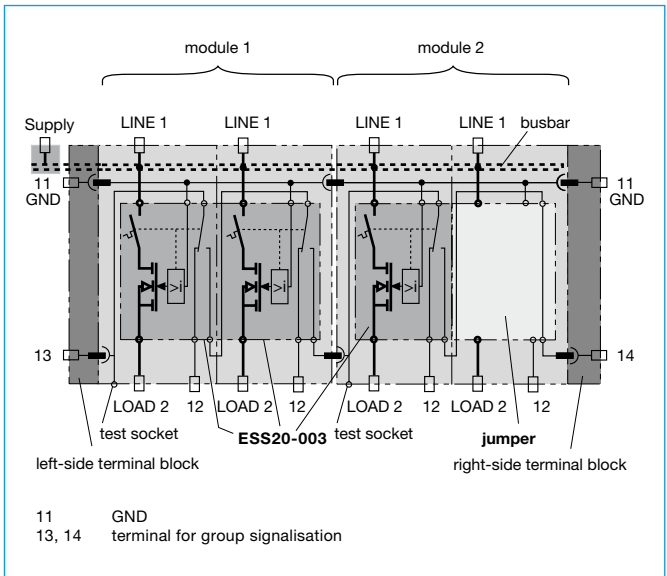

Dimensions (with type ESS20)

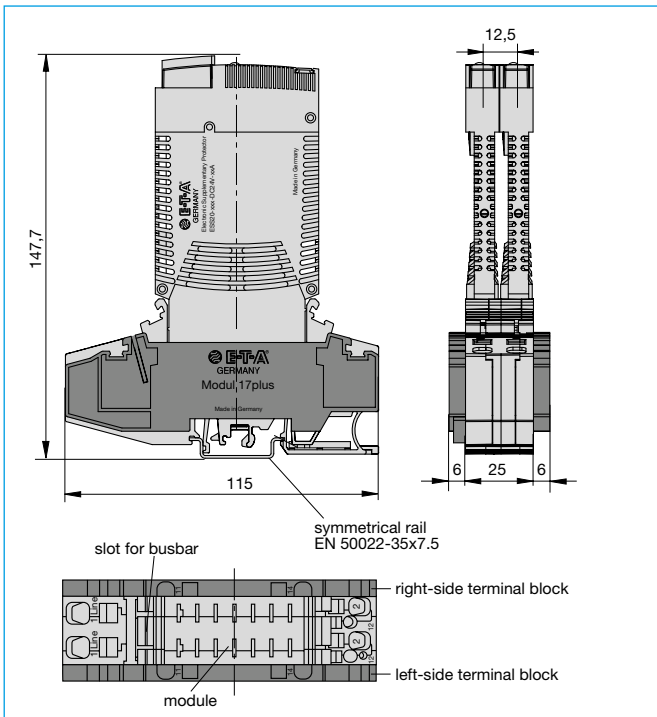

Dimensions (with type ESS30-S)

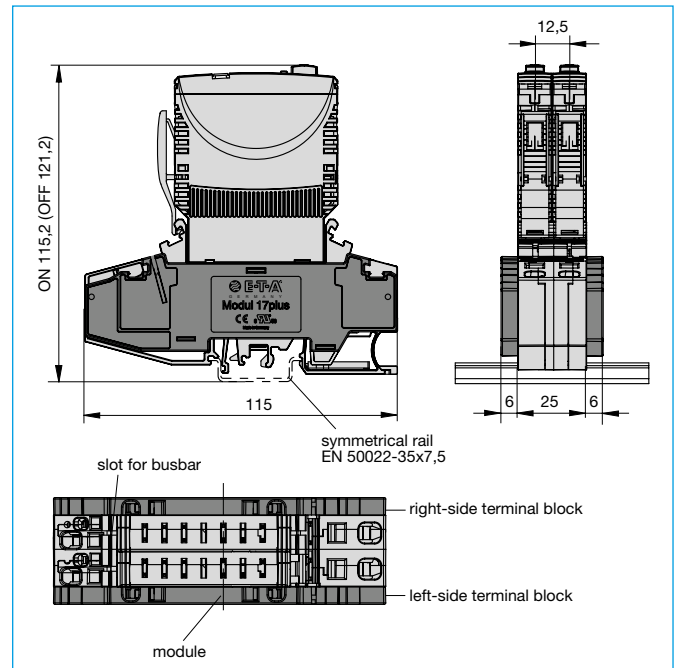

Pin selection, fitted with ESS20-124

ESS20-124 Module 17 plus

LINE (+)	(1.1, 1.2)
GND	(11)
RE	(13)
RE	(14)
SF	(12.1, 12.2)
LOAD (+)	(2.1, 2.2)

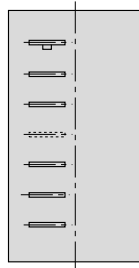

Pin selection, fitted with ESS30-S003

ESS30-S003 Module 17 plus

LINE (+)	(1.1, 1.2)
GND	(11)
SC	(13)
S0	(14)
SI	(12.1, 12.2)
LOAD (+)	(2.1, 2.2)

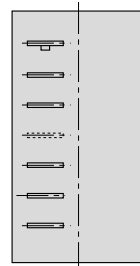

Connection diagram ESS20-124

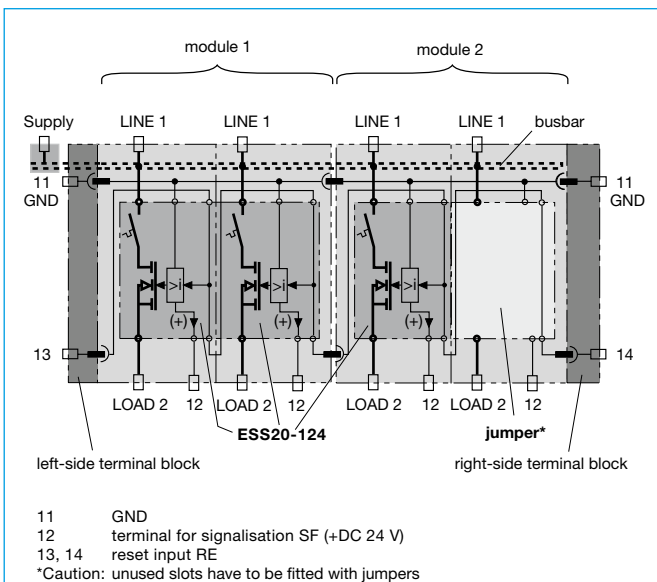

Connection diagram ESS30-S003

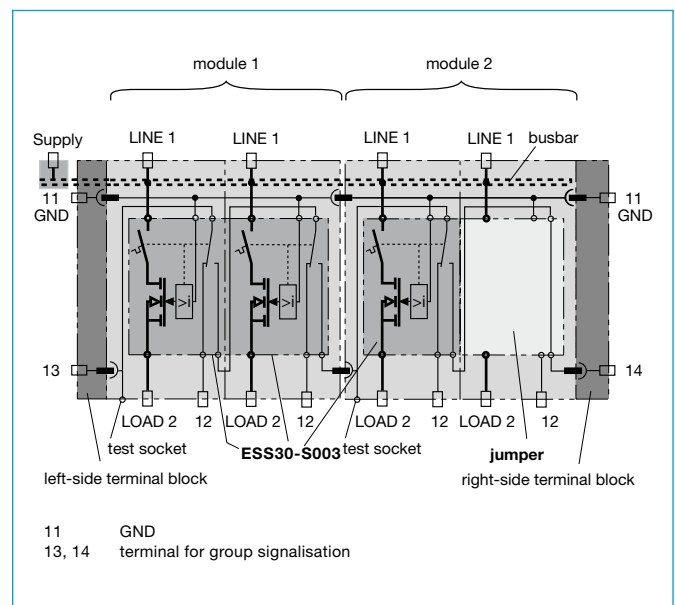

Dimensions (with type ESX10)

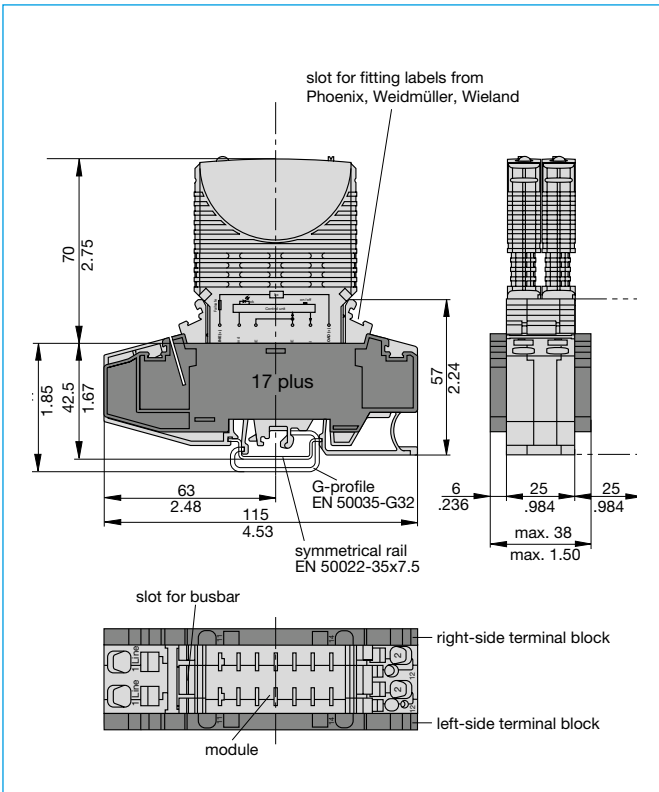

Pin selection, fitted with ESX10-124 (example)

ESX10-124 Module 17 plus

- LINE (+) (1.1, 1.2)
- GND (11)
- RE (13)

- RE (14)
- SF (12.1, 12.2)
- LOAD (+) (2.1, 2.2)



Connection diagram ESX10-...

Module 17plus with ESX10-100

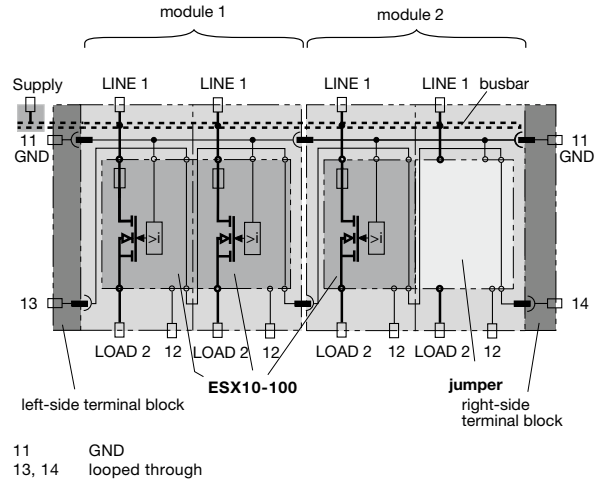

Module 17plus with ESX10-103/ESX10-S103

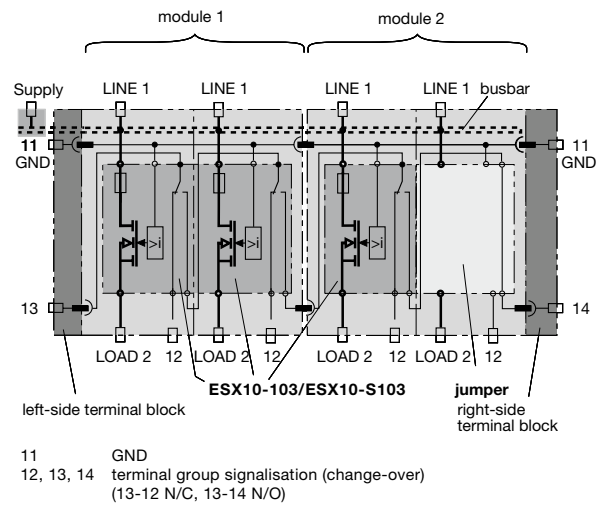

Connection diagram ESX10-...

Module 17plus with ESX10-115/-S115

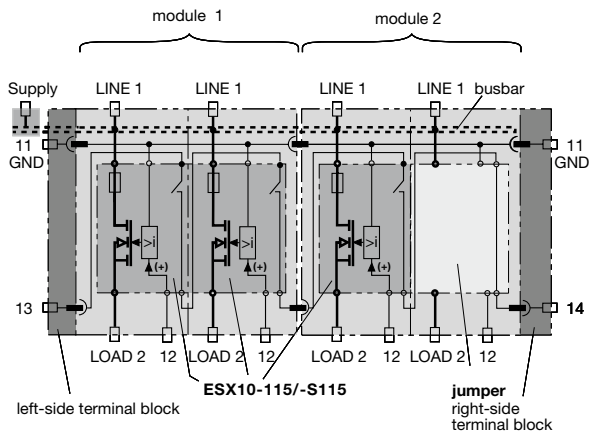

- 11 GND
- 12 terminal control signal ON (+24V DC)
- 13, 14 terminal group signalisation (N/O)

Module 17plus with ESX10-127/-S127

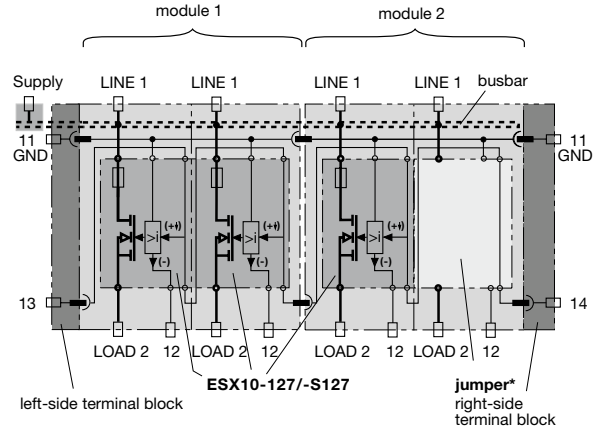

- 11 GND
 - 12 status indication SF $\overline{0V=OK}$
 - 13, 14 reset input RE (group reset), +24V falling edge
- *Caution: unused slots have to be fitted with jumpers

Module 17plus with ESX10-124/-S124

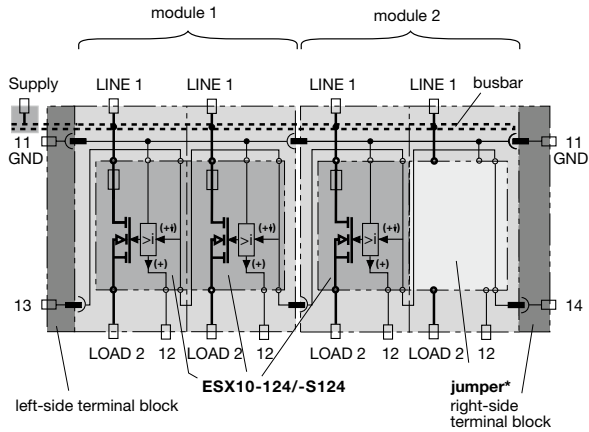

- 11 GND
 - 12 status indication SF +24V=OK
 - 13, 14 reset input RE (group reset), +24V falling edge
- *Caution: unused slots have to be fitted with jumpers

Module 17plus with ESX10-125/-S125

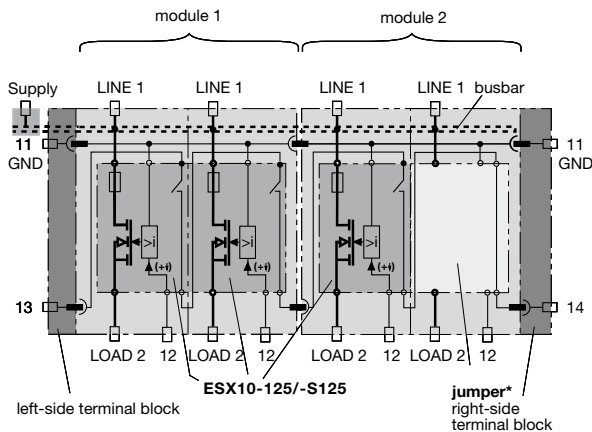

- 11 GND
 - 12 reset input RE (single reset), +24V falling edge
 - 13, 14 terminal group signalisation (N/O)
- *Caution: unused slots have to be fitted with jumpers

Dimensions (with type E-1048-S7xx)

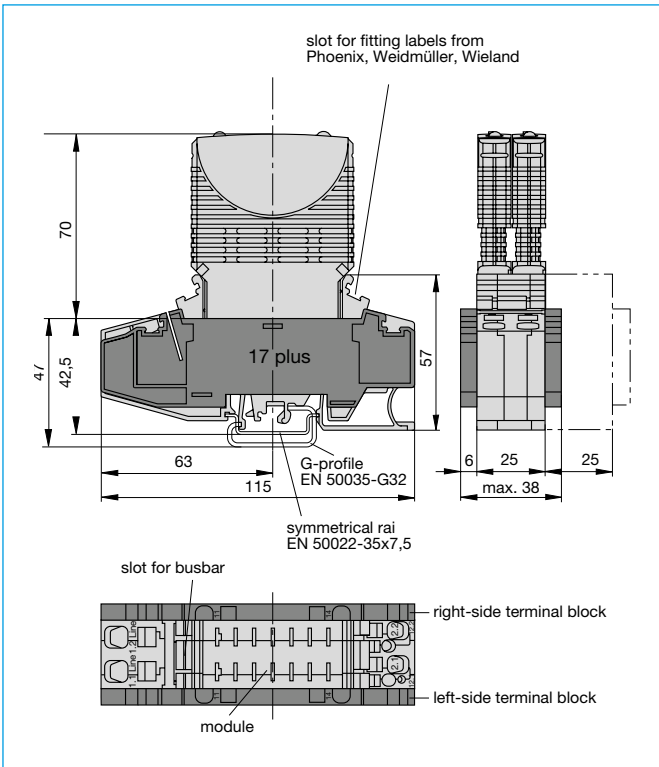

Connection diagram E-1048-S7xx

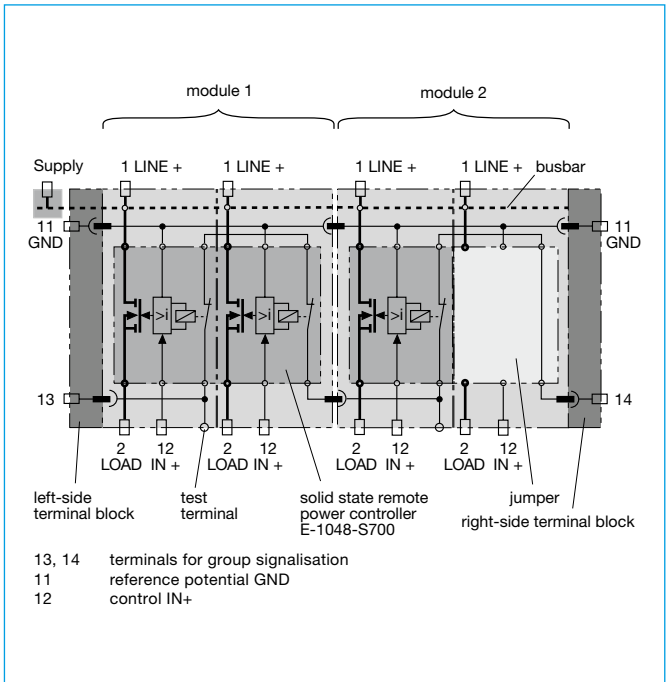

Pin selection, fitted with E-1048-S7..

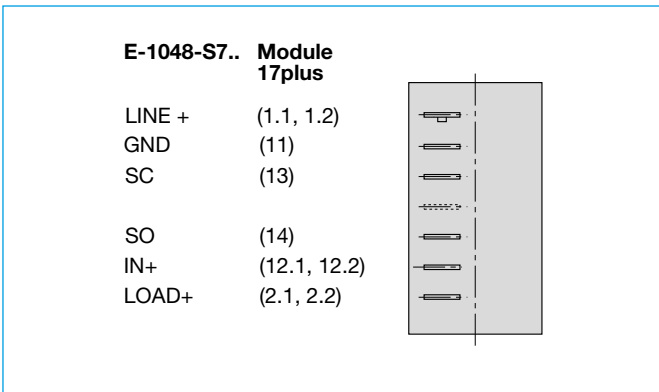

Accessories

Busbar 32 A

X 222 005 01 blue insulation, 500 mm/19.68 in.
X 222 005 02 red insulation, 500 mm/19.68 in.
X 222 005 03 grey insulation, 500 mm/19.68 in.
 up to 32 A continuous load

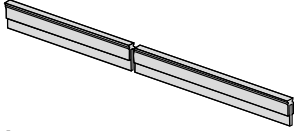

Busbar 50 A

Y 307 016 01 non-insulated, 500 mm/19.68 in.
 up to 50 A continuous load;
 plugged in completely, protected against brush contact

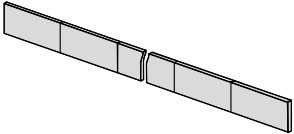

Busbar 50 A

Y 307 016 11 non-insulated, 500 mm/19.68 in.
 up to 50 A continuous load

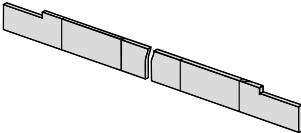

End bracket

X 222 004 01
 Width 10 mm

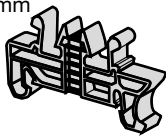

Screw terminal for busbar

X 211 156 01 non insulated
 (up to 35 mm²)

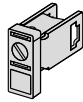

Retaining clip for circuit breaker 3600/3900

recommended for fitting the devices
Y 300 581 11

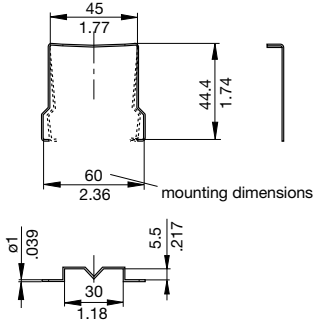

Retaining clip for circuit breaker 2210

recommended for fitting single pole devices
Y 302 974 21

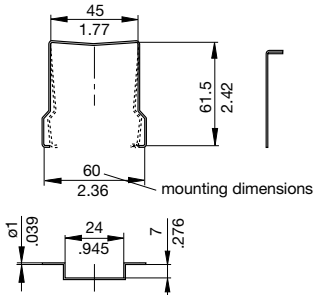

Retaining clip Y 308 792 01

recommended for tight fit of types
 ESX10 / E-1048-S6xx / SB-S11-P1-xx
 and terminal blocks type 17 and 17plus

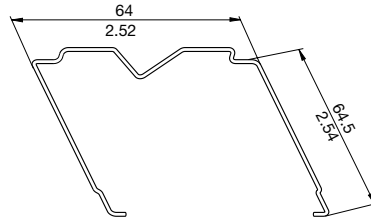

Retaining clip Y 307 754 01

recommended for tight fit of types
 ESS20 / ESX10

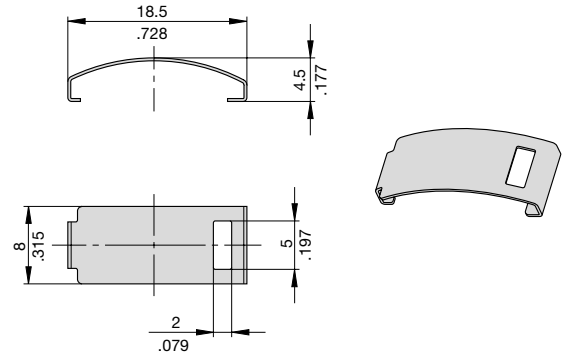

Jumper

SB-S11-P1-01-1-1A

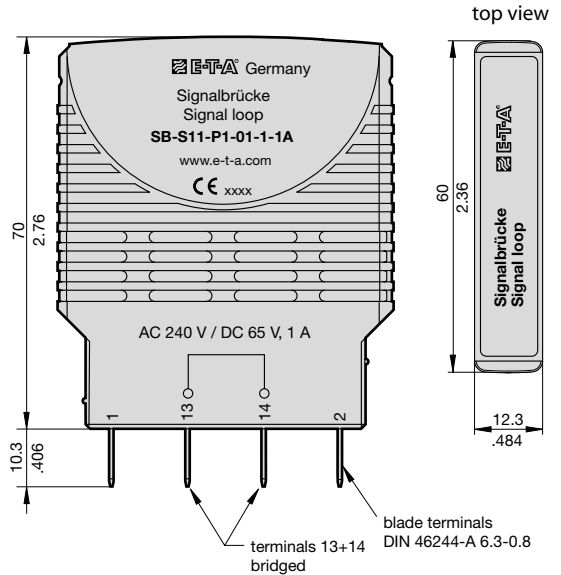

Labels

marking area 6 x 10 mm
 (ordering unit 10 pcs = 1 strip)
Y 307 942 61

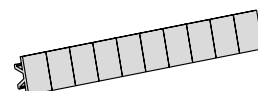

Installation example for retaining clip

ESS20 with retaining clip **Y 307 754 01**
for power distribution system module 17plus

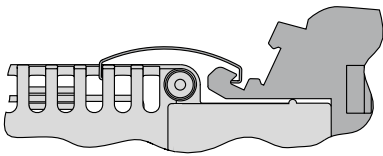
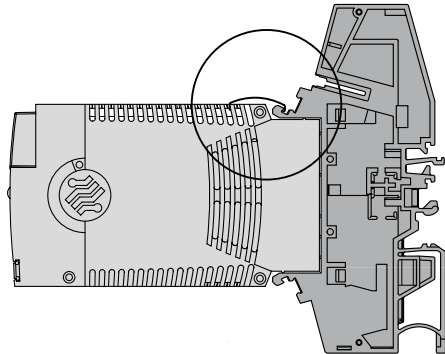

Removal of retaining clip **Y 307 754 01**

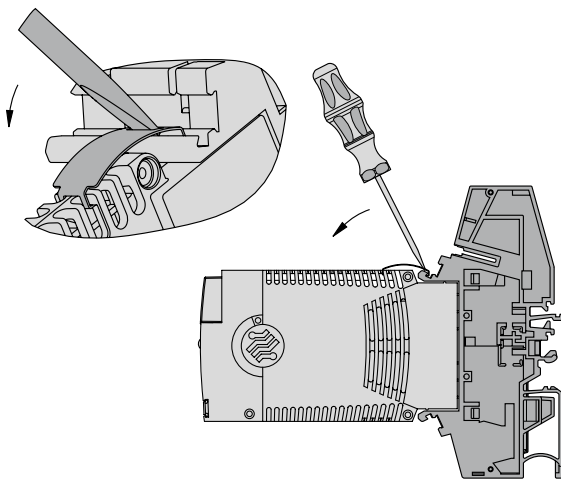

Installation example for busbar

**Installation for busbar 32 A (X222 005 01/02/03)
in Module 17plus**

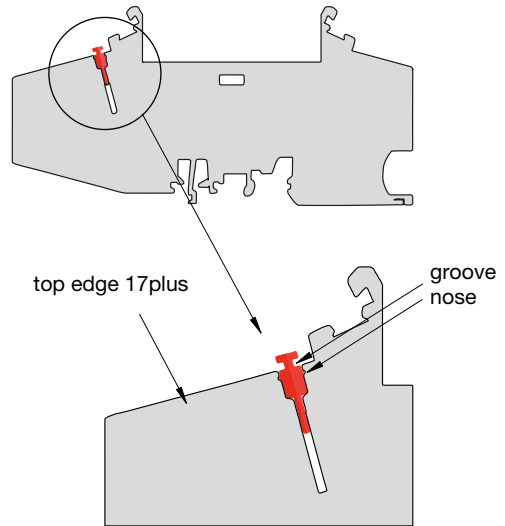

When mounting several modules side by side, proper insertion of the 32 A busbar X 222 005 01/02/03 has to be observed, i.e. the busbar must be pushed in evenly across the whole length from left to right, repeatedly if necessary. The groove of the busbar must be flush with the top edge of the Module 17plus.

Please ensure that the busbar audibly latches in into the Module 17plus.