



Chipsmall Limited consists of a professional team with an average of over 10 year of expertise in the distribution of electronic components. Based in Hongkong, we have already established firm and mutual-benefit business relationships with customers from,Europe,America and south Asia,supplying obsolete and hard-to-find components to meet their specific needs.

With the principle of "Quality Parts,Customers Priority,Honest Operation,and Considerate Service",our business mainly focus on the distribution of electronic components. Line cards we deal with include Microchip,ALPS,ROHM,Xilinx,Pulse,ON,Everlight and Freescale. Main products comprise IC,Modules,Potentiometer,IC Socket,Relay,Connector.Our parts cover such applications as commercial,industrial, and automotives areas.

We are looking forward to setting up business relationship with you and hope to provide you with the best service and solution. Let us make a better world for our industry!



## Contact us

Tel: +86-755-8981 8866 Fax: +86-755-8427 6832

Email & Skype: info@chipsmall.com Web: www.chipsmall.com

Address: A1208, Overseas Decoration Building, #122 Zhenhua RD., Futian, Shenzhen, China



LOC		DIST		REVISIONS			
AD	00	REV	DATE	BY	CHK	APPV	
A1		REVISED PER ECO-08-010892	05MAY08	HMR	SM		

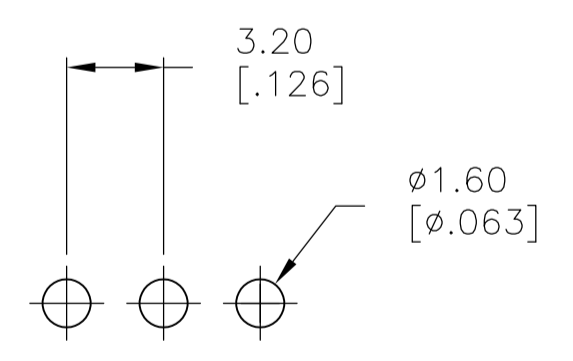
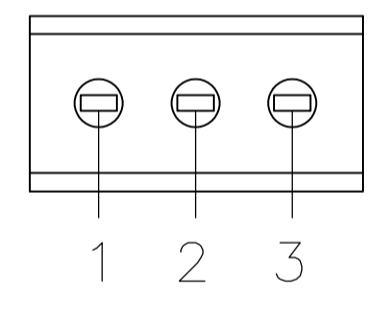
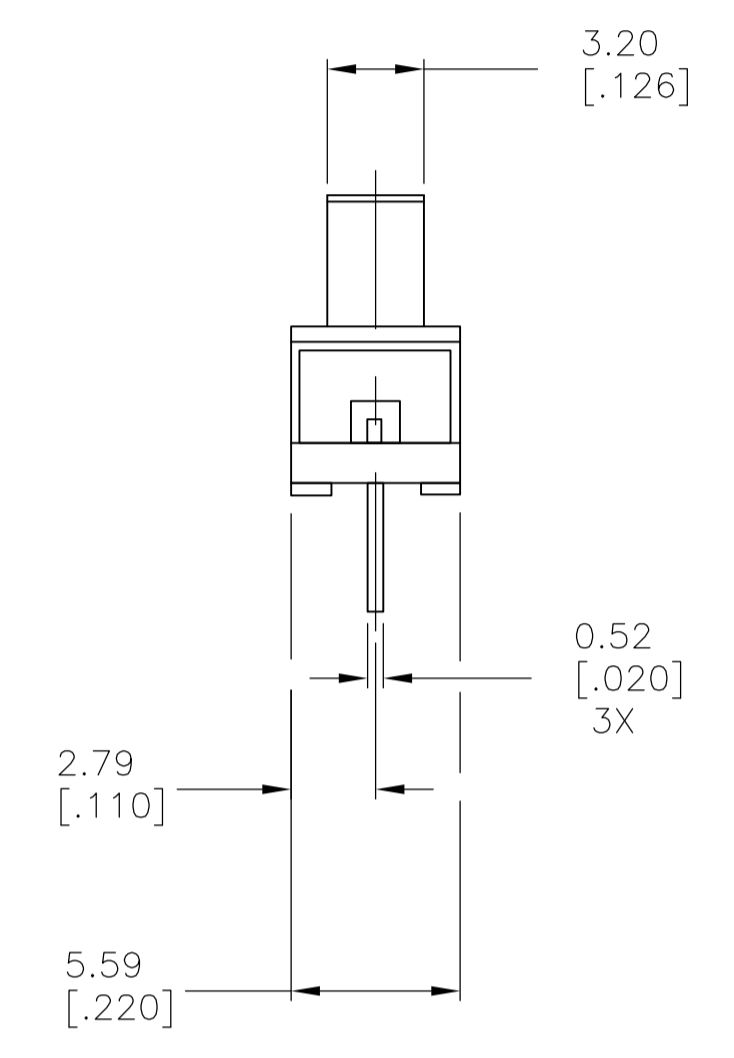
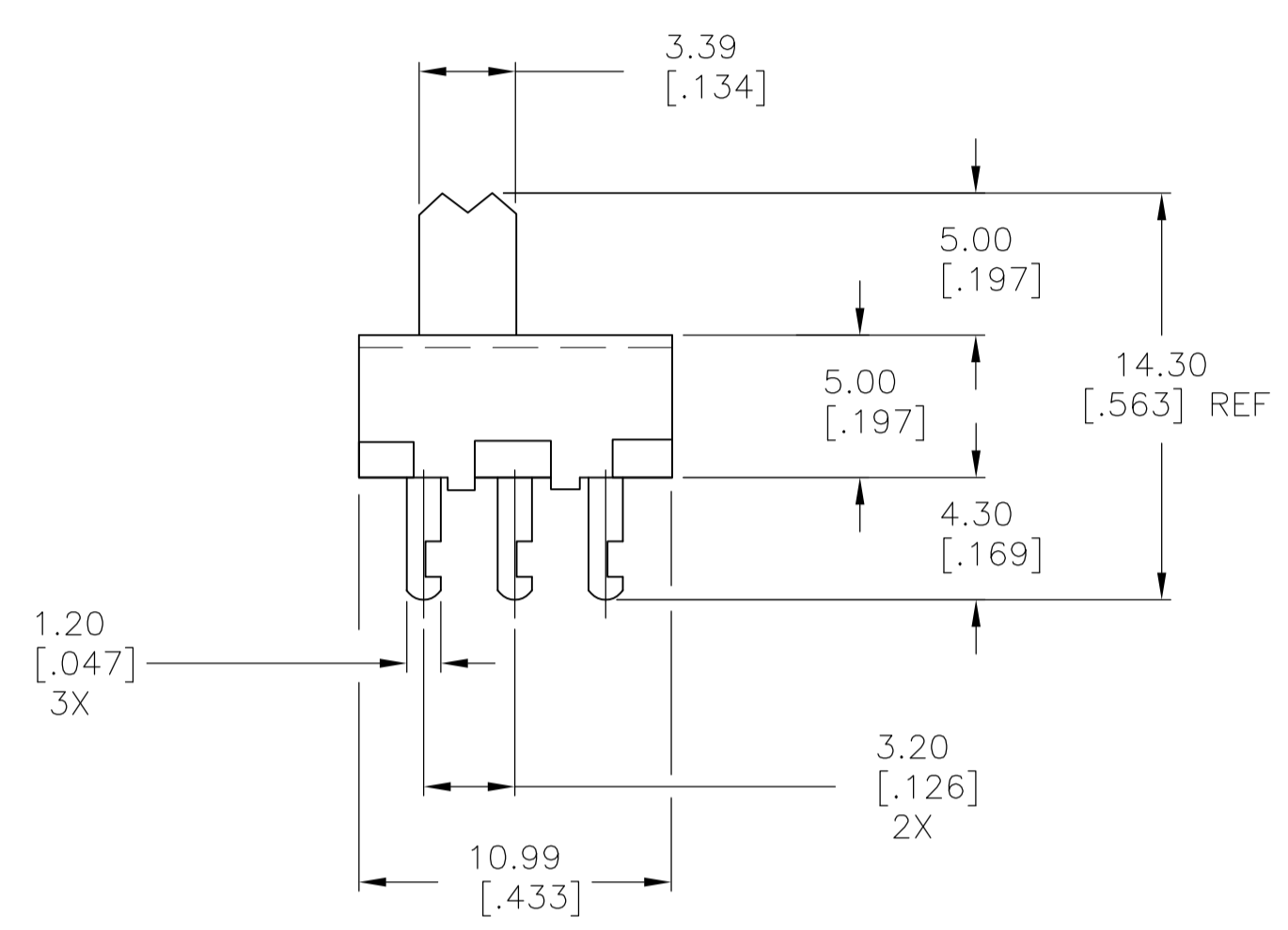
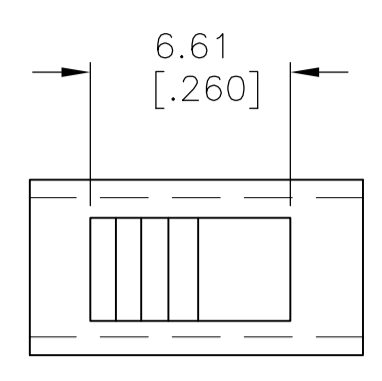

RECOMMENDED HOLE LAYOUT

SPECIFICATIONS:  
 BREAK-BEFORE-MAKE

MATERIALS:  
 FRAME- STEEL, ZINC PLATE  
 ACTUATOR- PBT G30, BLACK  
 FIXED CONTACT/TERMINAL- COPPER ALLOY, SILVER OVER NICKEL PLATE  
 MOVING CONTACT- COPPER ALLOY, SILVER OVER NICKEL PLATE  
 COIL SPRING- STEEL WIRE  
 TERMINAL BOARD- PHENOLIC, UL94HB

ELECTRICAL:  
 CONTACT RATING- 300 MILLIAMPS@125V AC  
 CONTACT RESISTANCE- 30 MILLIOHMS MAX (INITIAL),60 MILLIOHMS AFTER TEST  
 INSULATION RESISTANCE- 500 MEGOHMS MIN AT SEA LEVEL  
 DIELECTRIC STRENGTH- 500 VAC RMS AT SEA LEVEL  
 LIFE EXPECTANCY- 10,000 CYCLES MIN. NO LOAD & 6,000 MIN AT RATED

MECHANICAL:  
 ACTUATION FORCE- 350 +/-200 GRAMS  
 TRAVEL- .106 (2.69MM)

ENVIRONMENTAL:  
 OPERATING TEMPERATURE- -20 TO +85 DEGREES C  
 STORAGE TEMPERATURE- -40 TO +100 DEGREES C  
 RESISTANCE TO SOLDER HEAT- 260 C FOR 10 SEC PER 109-202, COND. B  
 SOLDERABILITY- PER EIA-364-56A, PROCEDURE 3, COND. B

- NOTES:  
 1 ALL MATERIALS AND FINISHES SHALL COMPLY WITH EU DIRECTIVE 2002/95/EC OF 27JAN2003 (ROHS)  
 2 ALL PERFORMANCES SPECIFICATIONS WERE TESTED IN ACCORDANCE WITH JIS-C-5441 UNLESS OTHERWISE STATED.

1-2	2-3	SLS121104	1825077-1
LEFT	RIGHT	ALCO PART NUMBER	TE PART NUMBER
ACTUATOR POSITION			

THIS DRAWING IS A CONTROLLED DOCUMENT.		DIN B.S.VISWESWARA CHK M.S.SARVER		DT/MAR/08 Tyco Electronics Corporation Harrisburg, PA 17105-3608	
DIMENSIONS: mm [INCHES]		TOLERANCES UNLESS OTHERWISE SPECIFIED:		NAME	
0 PLC ± - 1 PLC ± - 2 PLC ± - 3 PLC ± 0.25(010) 4 PLC ± - ANGLES ± -		PRODUCT SPEC		SLIDE SWITCH (SLS-121-1) SPDT W/O TABS	
MATERIAL		FINISH		SIZE CAGE CODE DRAWING NO	
				A1 00779 C=1825077	
CUSTOMER DRAWING		SCALE		SHEET 1 OF 1 REV A1	
		4:1			