



Chipsmall Limited consists of a professional team with an average of over 10 year of expertise in the distribution of electronic components. Based in Hongkong, we have already established firm and mutual-benefit business relationships with customers from,Europe,America and south Asia,supplying obsolete and hard-to-find components to meet their specific needs.

With the principle of “Quality Parts,Customers Priority,Honest Operation,and Considerate Service”,our business mainly focus on the distribution of electronic components. Line cards we deal with include Microchip,ALPS,ROHM,Xilinx,Pulse,ON,Everlight and Freescale. Main products comprise IC,Modules,Potentiometer,IC Socket,Relay,Connector.Our parts cover such applications as commercial,industrial, and automotives areas.

We are looking forward to setting up business relationship with you and hope to provide you with the best service and solution. Let us make a better world for our industry!



Contact us

Tel: +86-755-8981 8866 Fax: +86-755-8427 6832

Email & Skype: info@chipsmall.com Web: www.chipsmall.com

Address: A1208, Overseas Decoration Building, #122 Zhenhua RD., Futian, Shenzhen, China



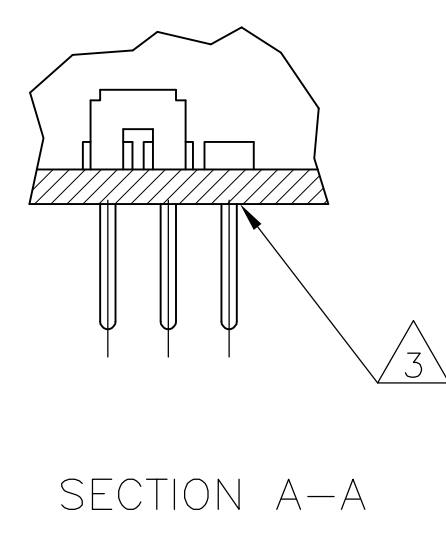
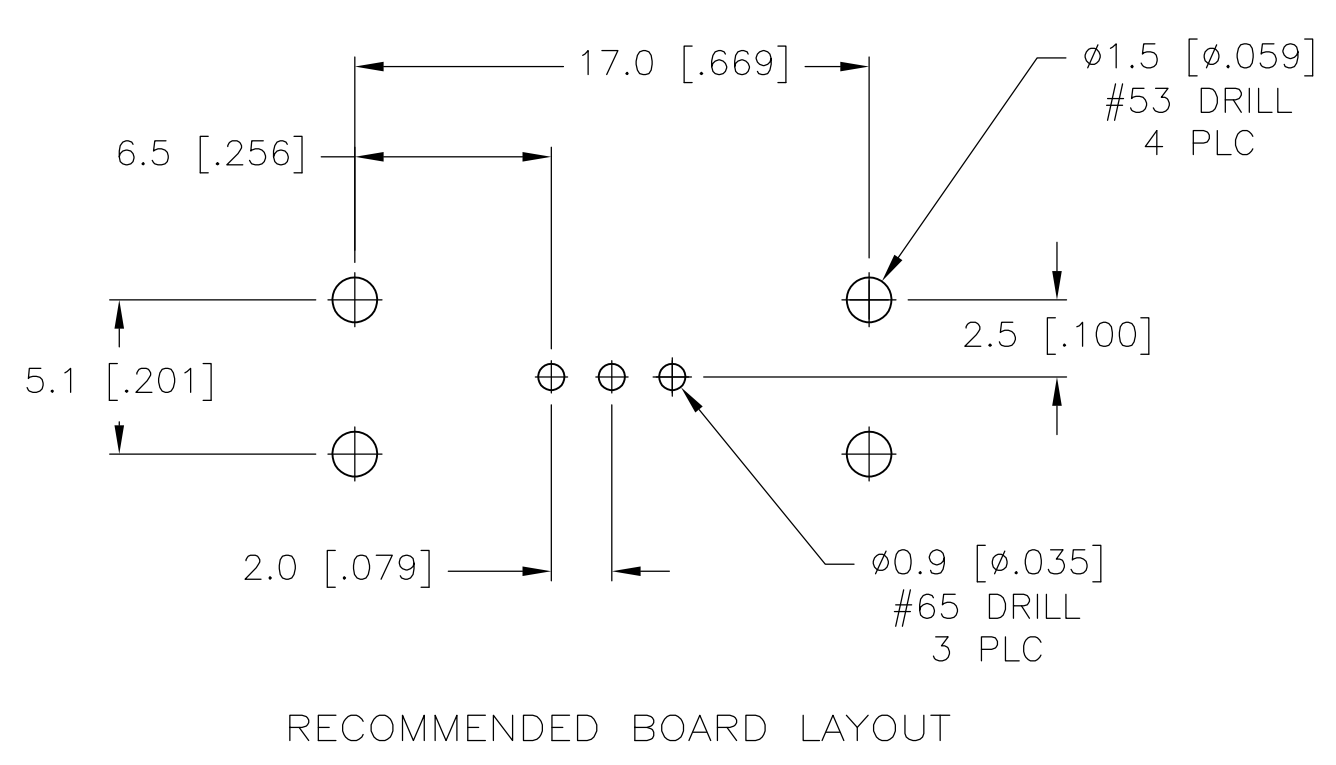
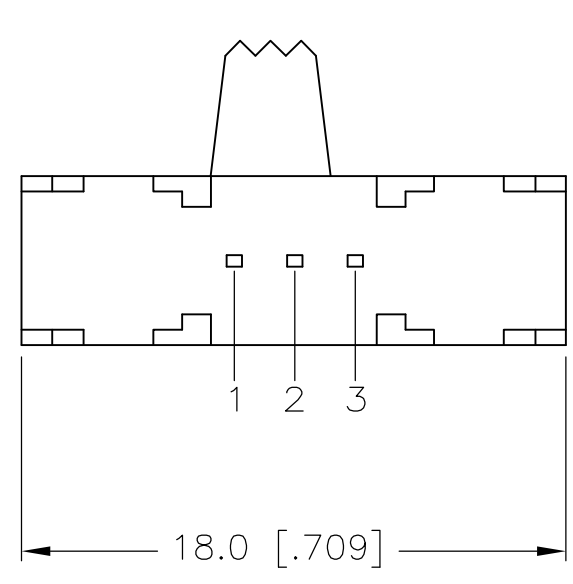
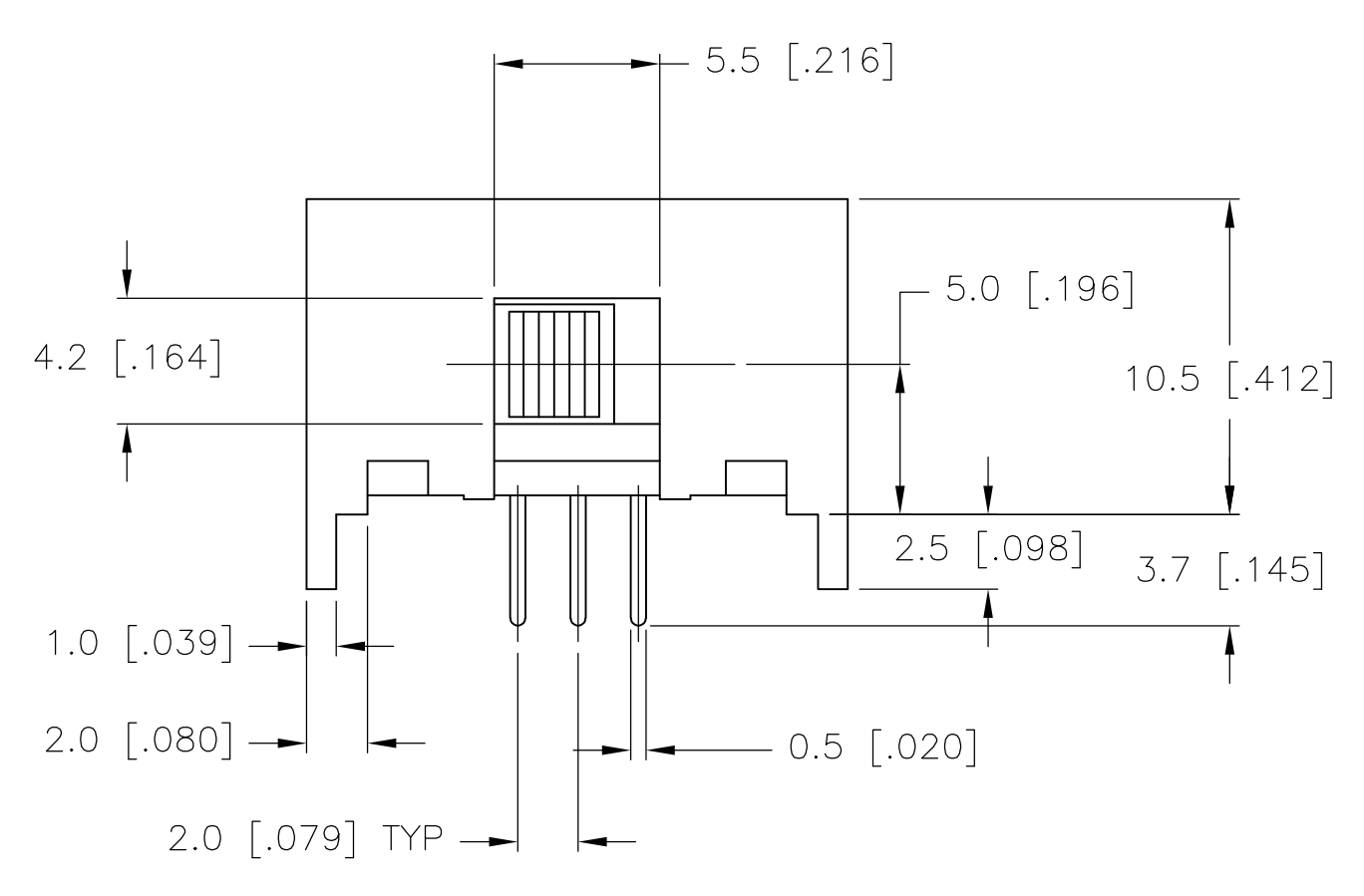
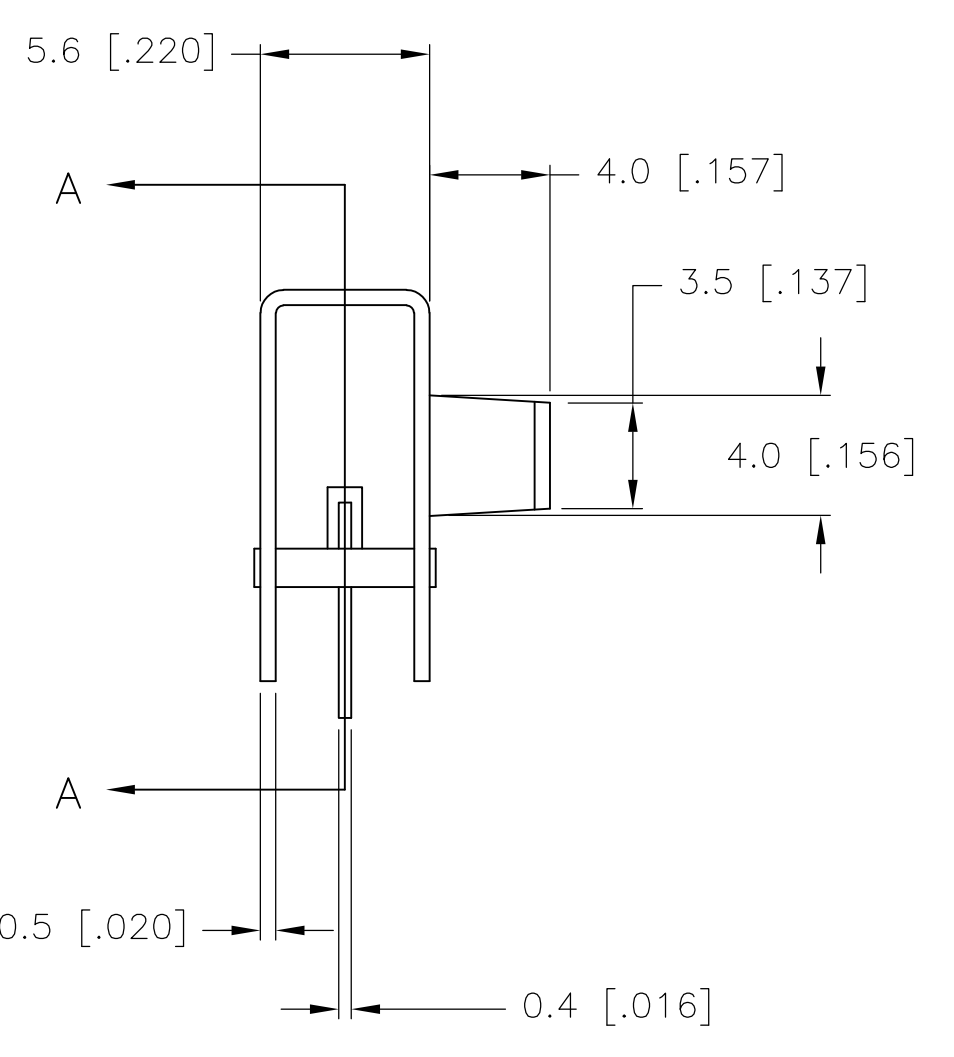
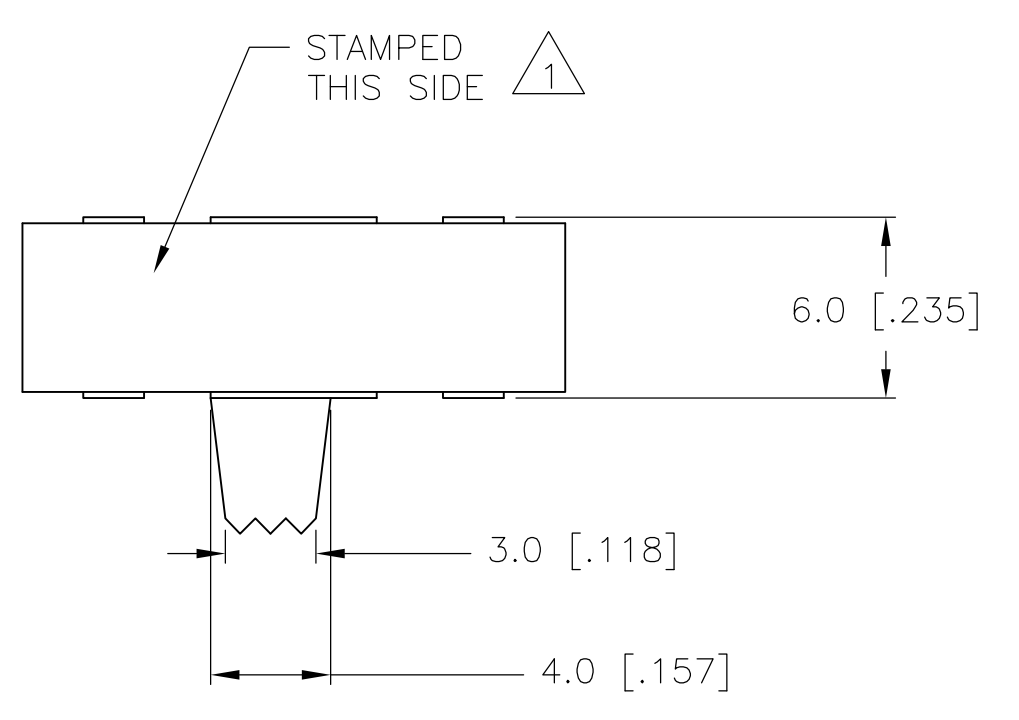

SPECIFICATIONS
 MAKE-BEFORE-BREAK

MATERIALS:
 ACTUATOR- POM, UL94HB BLACK
 TERMINAL BOARD- PHENOLIC LAMINATED SHEET, UL94HB, NATURAL
 FRAME- STEEL, NICKEL PLATE
 TERMINAL/FIXED CONTACT- COPPER ALLOY, GOLD OR SILVER OVER NICKEL PLATE
 MOVING CONTACT- COPPER ALLOY, GOLD OR SILVER OVER NICKEL PLATE
 DETENT BALL- STEEL
 COIL SPRING- GALVANIZED SPRING WIRE
 SEAL- EPOXY

ELECTRICAL:
 CONTACT RATING- .4VA@20VDC OR PEAK AC (GOLD); 300mA@125V AC (SILVER)
 INITIAL CONTACT RESISTANCE- 30 milliohm max.
 FINAL CONTACT RESISTANCE- 100 milliohm max. (AFTER TEST)
 INSULATION RESISTANCE- 1,000 Megohms min.
 DIELECTRIC STRENGTH- 500V RMS@SEA LEVEL
 LIFE EXPECTANCY- 15,000 CYCLES MIN.

MECHANICAL:
 ACTUATION FORCE- 600+/-300 GRAMS
 TRAVEL- 2.0 +/-0.50 (.079 +/-0.020)

ENVIRONMENTAL:
 OPERATING TEMPERATURE- -20 TO +85 DEGREES C
 STORAGE TEMPERATURE- -40 TO +100 DEGREES C
 RESISTANCE TO SOLDER HEAT PER 109-202, CONDITION B
 SOLDERABILITY PER EIA-364-52, CLASS 2, CATEGORY 1, 95% MIN COVERAGE

NOTES:

- 1 COUNTRY OF ORIGIN AND TE LOGO LOCATED APPROXIMATELY AS SHOWN
2. ALL MATERIALS AND FINISHES SHALL COMPLY WITH EU DIRECTIVE 2002/95/EC OF 27JAN2003 (ROHS)
- 3 ANTI SOLDER WICK SEAL AT TERMINAL TO BOARD INTERFACE
4. ALL PERFORMANCE TESTING WAS DONE IN ACCORDANCE TO TYCO SPECIFICATION 102-2469

1825258-2	MSS1200RG04	GOLD	2 TO 1	2 TO 3
1825258-1	MSS1200R04	SILVER	2 TO 1	2 TO 3
TE PART NO.	T&B PART NO.	PLATING		

TERMINALS CONNECTED WHEN SLIDE IS IN POSITION SHOWN.

THIS DRAWING IS A CONTROLLED DOCUMENT.		DIN R BROWN 20DEC05	Tyco Electronics Corporation Harrisburg, Pa 17105-3608													
DIMENSIONS: mm		CHK M SARVER 20DEC05	NAME M SARVER 20DEC05													
TOLERANCES UNLESS OTHERWISE SPECIFIED:		PRODUCT SPEC														
<table border="1"> <tr><td>0 PLC</td><td>± -</td></tr> <tr><td>1 PLC</td><td>± 0.3 [0.12]</td></tr> <tr><td>2 PLC</td><td>± -</td></tr> <tr><td>3 PLC</td><td>± -</td></tr> <tr><td>4 PLC</td><td>± -</td></tr> <tr><td>ANGLES</td><td>± -</td></tr> </table>		0 PLC	± -	1 PLC	± 0.3 [0.12]	2 PLC	± -	3 PLC	± -	4 PLC	± -	ANGLES	± -	APPLICATION SPEC		
0 PLC	± -															
1 PLC	± 0.3 [0.12]															
2 PLC	± -															
3 PLC	± -															
4 PLC	± -															
ANGLES	± -															
MATERIAL - FINISH -		SIZE A1	CAGE CODE 00779	DRAWING NO. 1825258												
CUSTOMER DRAWING		SCALE 4:1	SHEET 1 OF 1	REV A1												